

Atoms

■ Definition

- the smallest particle that has the properties of an element, basic unit of matter
- surprising the number of different atoms is small (119)
- the number of combinations these atoms make are huge

Democritus Theory

- Greek Philosopher in the 4th century B.C
 - believed that all matter consisted of extremely small particles
 - suggested these particles are made of invisible units called atoms
 - term atom is derived from a Greek word meaning “unable to divide”
 - believed there were different types of atoms, liquids: round, smooth solids: rough, prickly
 - unable to provide evidence that an atom existed, therefore many people were very skeptical.

His ideas did agree with later scientific theory, but did not explain chemical behavior, and was not based on the scientific method – but just philosophy

Dalton's Atomic Theory

- John Dalton

- interested in predicting the weather SO.. studied the behavior of gases in the air, concluded that a gas consists of individual particles

Dalton's Atomic Theory

■ 5 Principles

1. All matter is made of indivisible and indestructible atoms
2. All atoms of a given element are identical in their physical and chemical properties
3. Atoms of different elements differ in their physical and chemical properties
4. Atoms of different elements combine in simple whole-numbers ratios to form compounds

Dalton's Atomic Theory

5. Chemical reactions consist of the combination, separation, or rearrangement of atoms but, even atoms are combined, separated, or rearranged – they never changed into atoms of another element.
- theory explained most of the chemical data of the day and was readily accepted
 - evidence since has shown the first two principles are not valid
 - NOT discarded only modified

Thomson's Experiment

■ J.J Thomson

1st experiment (1890')

- pumped most the air out of a glass tube, placed a metal plate at each end

- applied a voltage to two metal plates became positively charged: anode

other became negatively charged: cathode

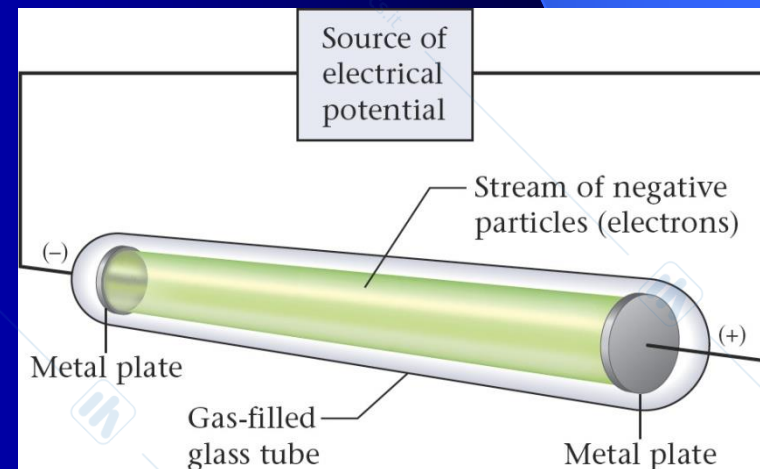

Thomson's Experiment Cont.

2nd experiment

- placed a charged metal plate on either side of the glass tube

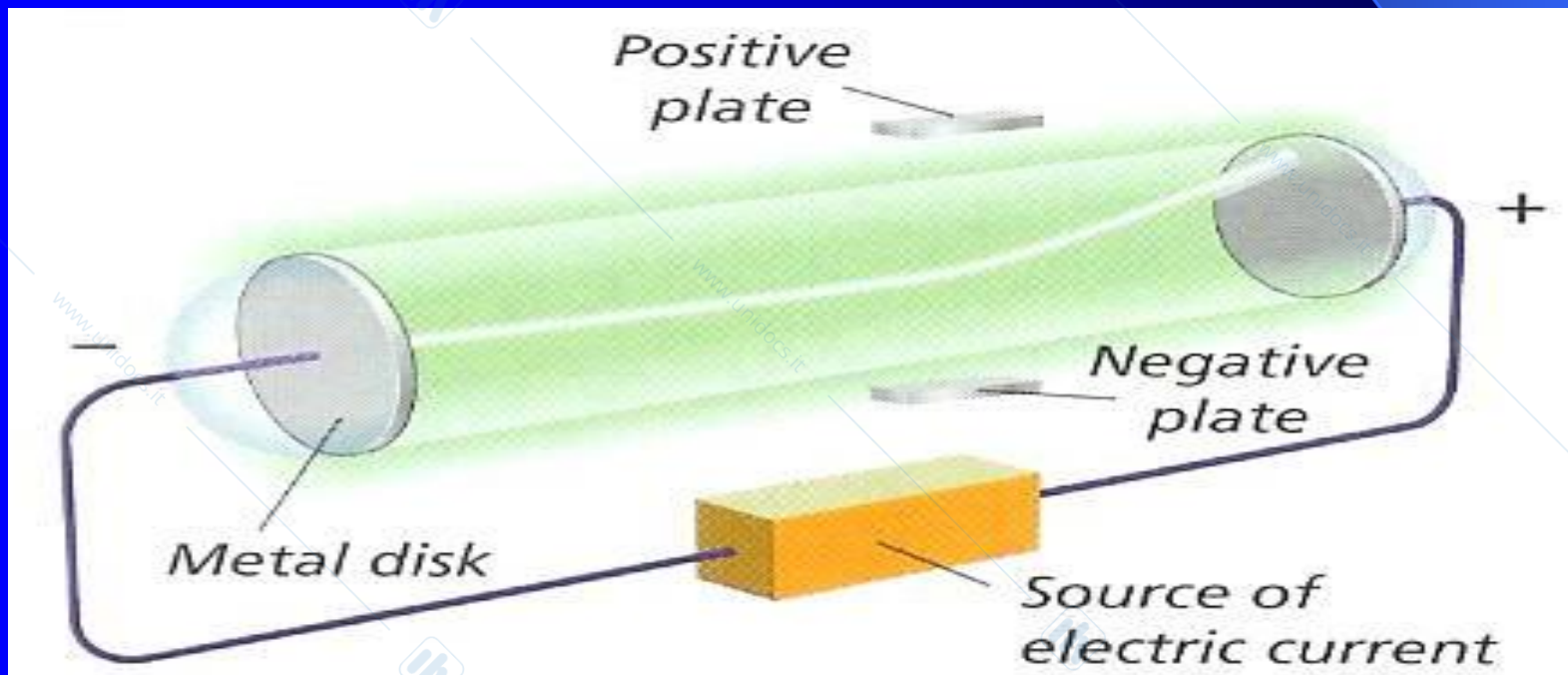

Discovery of the Electron

In 1897, J.J. Thomson used a cathode ray tube to deduce the presence of a negatively charged particle: the electron

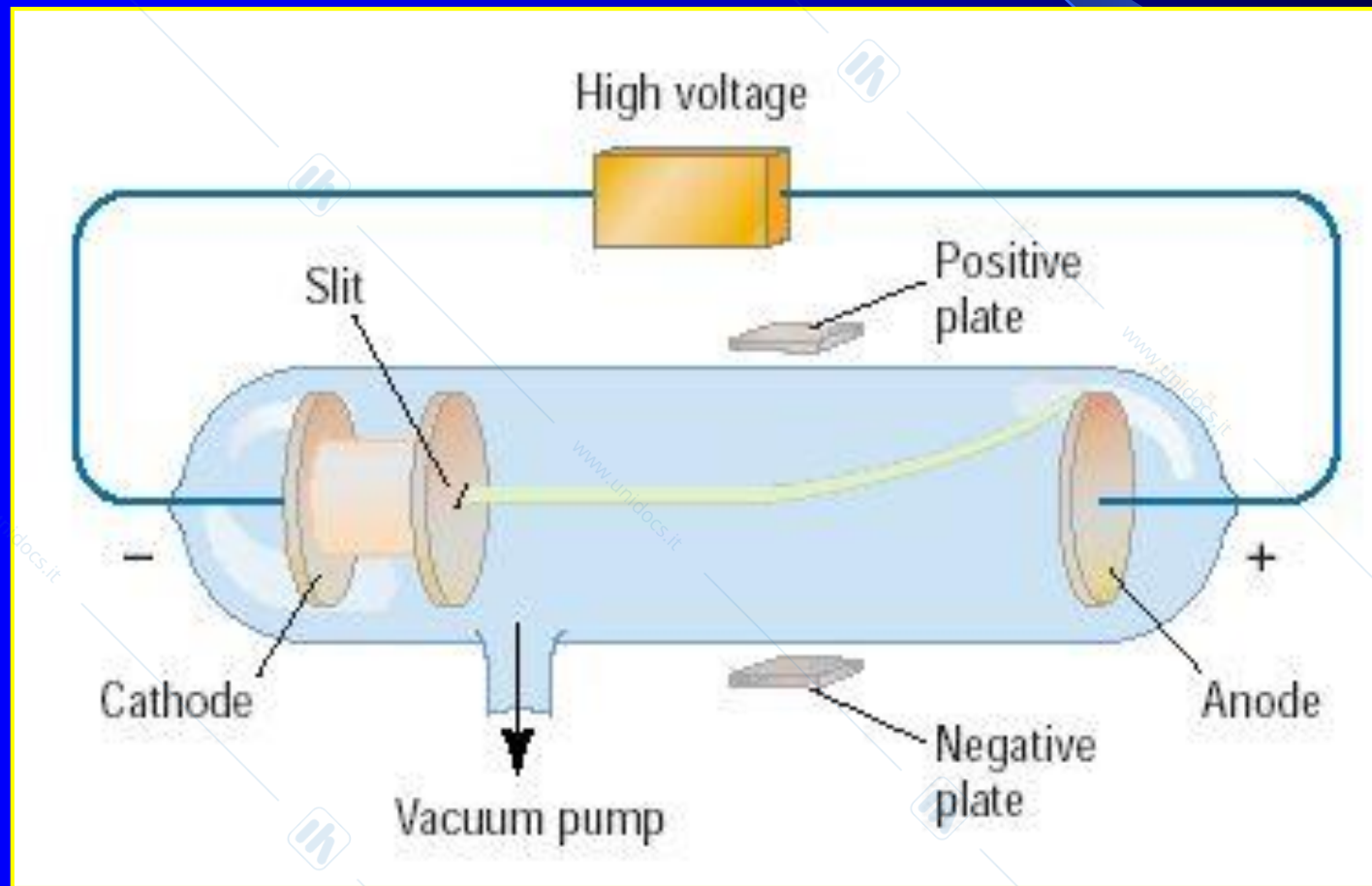

Thomson's Experiment Cont.

■ Observations

1st experiment

- glowing ray emerged between the cathode and anode

2nd experiment

- charged plates caused the beam to deflect/bend

- repelled from the negative

- attracted to the positive

■ Conclusion

- beam of light (stream of charged particles)

- negative

- Raggi anodici
- Goldstein nel 1886 aveva modificato un tubo di Crookes adottando un catodo costituito da una piastra metallica forata. Egli notò che la parete di vetro dietro al catodo diveniva fluorescente

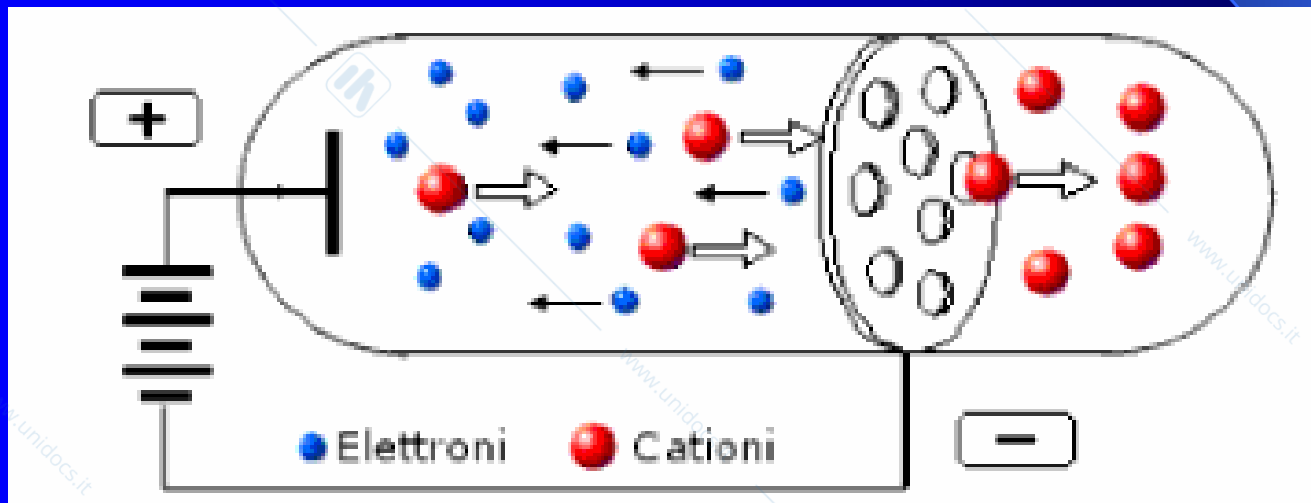

La deflessione dei raggi anodici, per mezzo di un campo elettrico o magnetico, è inferiore a quella subita dai raggi catodici a causa della *differenza di massa tra elettroni e ioni positivi*.

In other experiments made by using an higher voltage charged particles were released even by the anode. The size of these particles, heavier than the electrons, depended by the material the cathode is built.

Charged plates caused this beam to deflect/bend

- repelled from the positive
- attracted to the negative.

Protons were discovered

Conclusions from the Study of the Electron:

- a) Cathode rays have identical properties regardless of the element used to produce them. All elements must contain identically charged electrons.
- b) Atoms are neutral, so there must be positive particles in the atom to balance the negative charge of the electrons
- c) Electrons have so little mass that atoms must contain other particles that account for most of the mass

Thomson's Model

*

- Thomson believed that the electrons were like plums embedded in a positively charged “pudding,” thus it was called the “plum pudding” model
- Plum Pudding
 - negative particles are evenly scattered throughout an atom with a positively charged mass of matter
 - similar to that of chocolate chip ice cream
- later proved to be incorrect

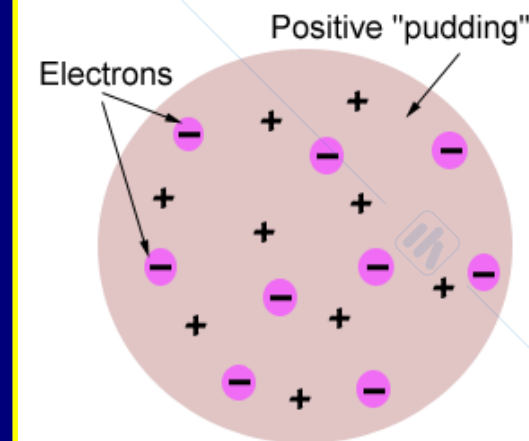

Rutherford's Theory

- Ernest Rutherford
 - a former student of Thomson came up with a more accurate picture of the atom in 1909
 - oversaw the now famous gold foil experiment
- Gold Foil Experiment

Rutherford's Experiment (1911)(Golden foil exp)

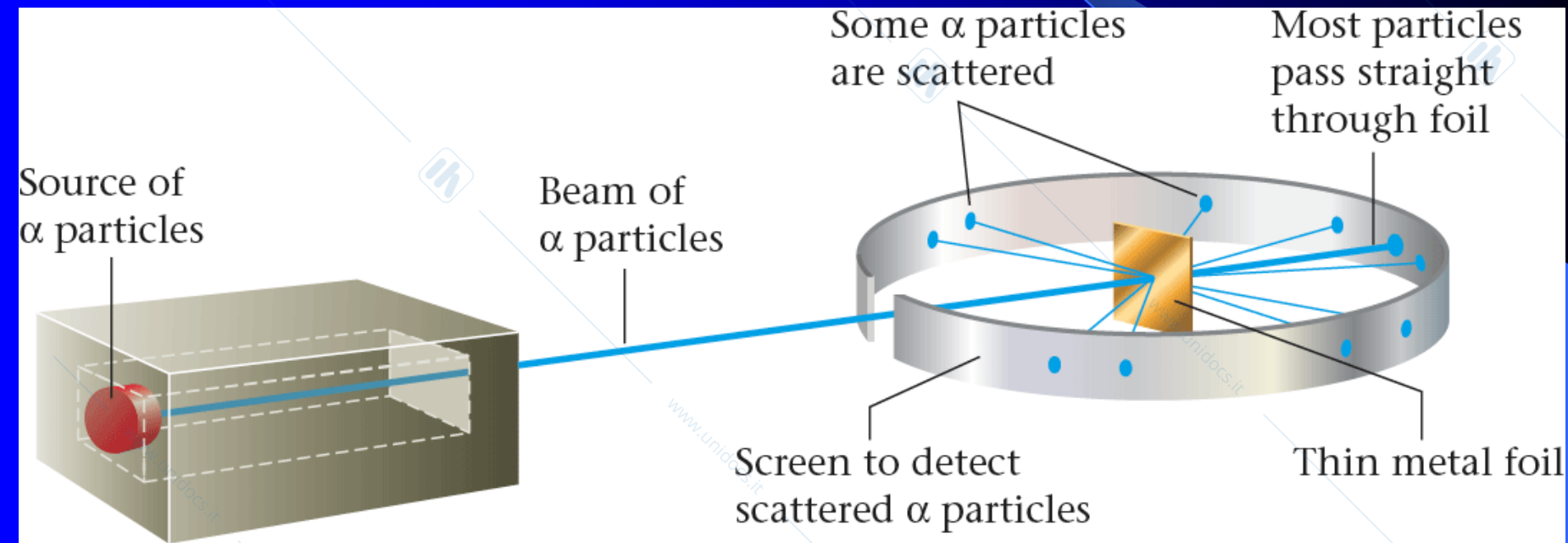

α particles are very small and positively charged

Results of the Rutherford experiment

the metal foil experiment would have stopped α particles if the plum pudding model had been correct

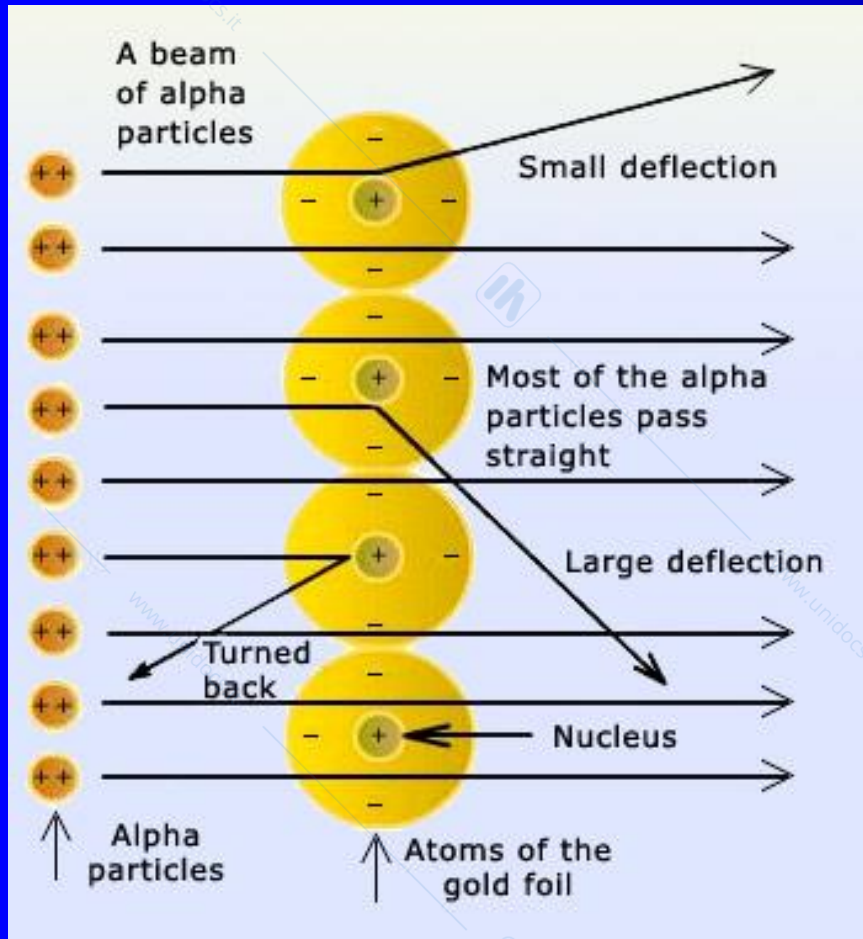

Actual results

The atom is mostly empty space

Gold Foil Experiment Cont.

- Observations
 - nearly all passed through undeflected and produced spots of light
 - some were widely deflected, and a few bounced straight back

What massive object did they hit?

atomic nucleus, an extremely dense positively charged center of the atom

■ Results of the Rutherford experiment

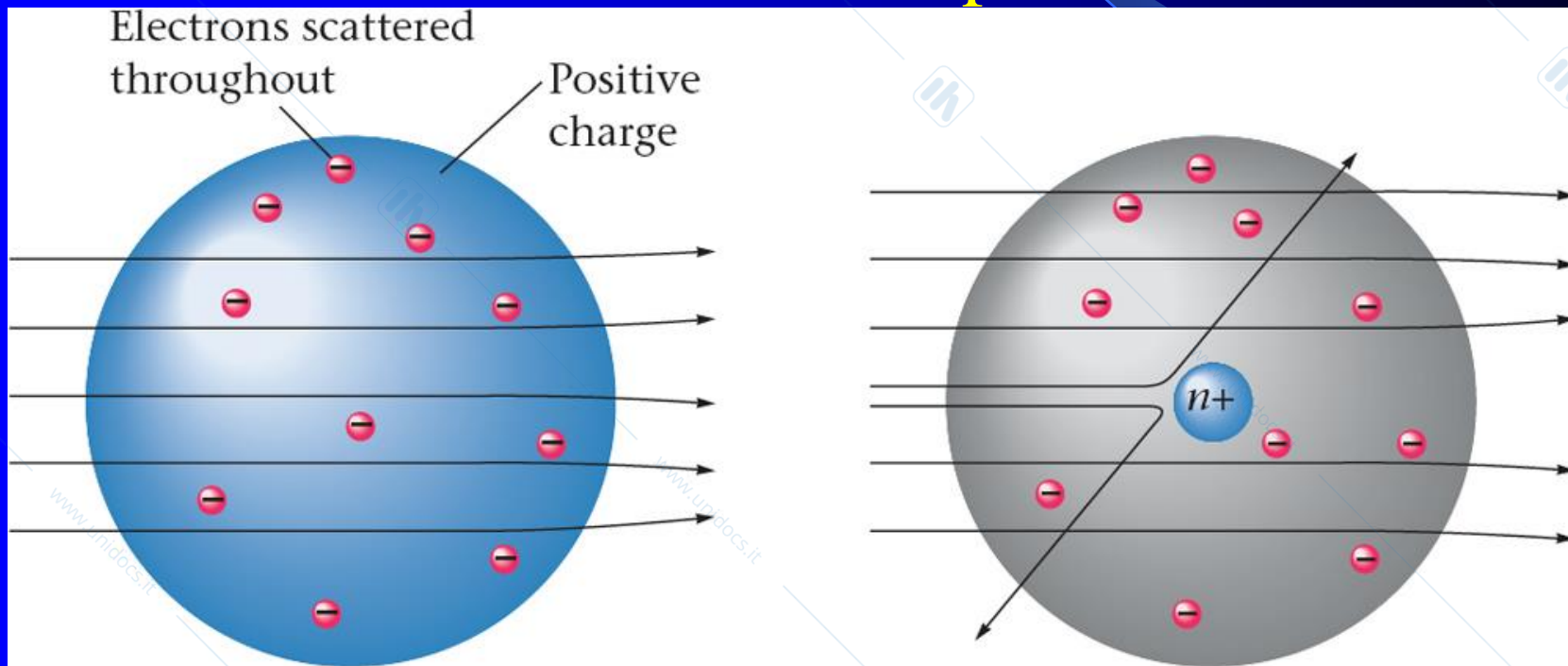

(a) The results that the metal foil experiment would have yielded if the plum pudding model had been correct

(b) Actual results

Gold Foil Experiment Cont.

- the nucleus and surrounding electrons occupy only a tiny fraction of the atomic volume
- diameter of an atom is generally about 10,000 times greater than the diameter of its nucleus
- * If the nucleus were the size of the period at the end of this sentence, the outer edges of the atom would be located some 3.3 meters away *

The Rutherford Atomic Model

- Based on his experimental evidence:
 - The atom is mostly empty space
 - All the positive charge, and almost all the mass is concentrated in a small area in the center. He called this a “nucleus”
 - The nucleus is composed of positive particles).
 - The electrons distributed around the nucleus, and occupy most of the volume
 - His model was called a “nuclear model”. Electrons move around nucleus



Figura 1.4. Il modello dell'atomo secondo Rutherford.

Protons

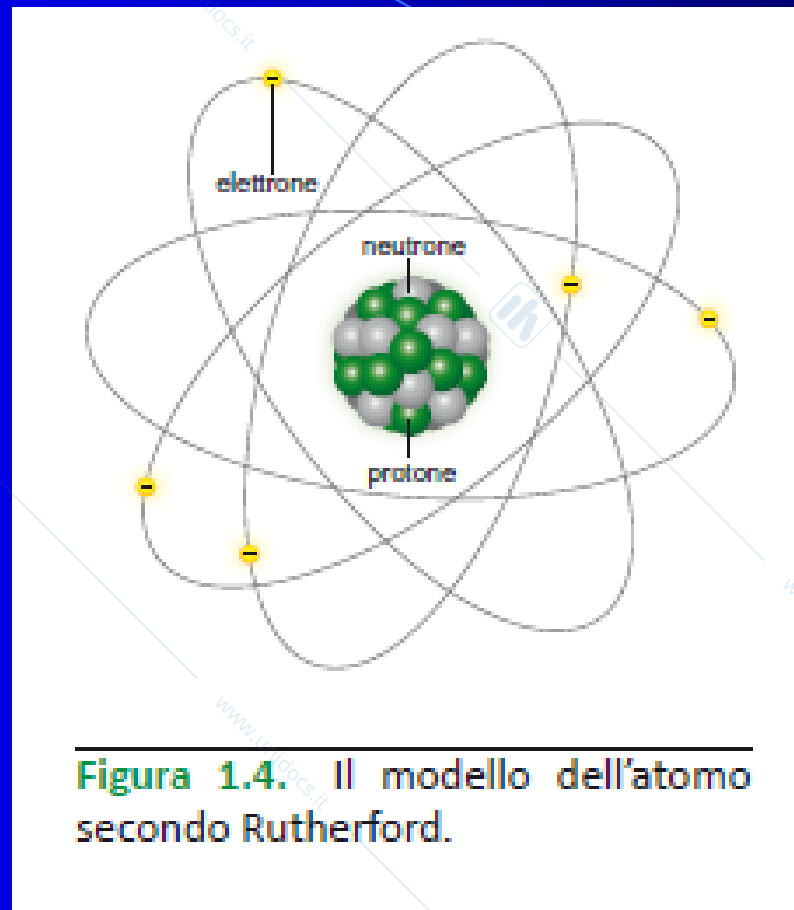

- Definition
 - a positively charge subatomic particle that is found in the nucleus of an atom
- About Protons
 - proton is nearly 2000 times more massive than the electron, but equal in charge and opposite in sign to the electron
 - number of protons in the nucleus is electrically balanced by an equal number of electrons
ex. oxygen atom: contains 8 electrons
and protons: neutral atom, no net charge

Electron

■ Definition

- a negatively charged subatomic particle that is found in the space outside the nucleus
- name comes from the Greek word for amber
- *Amber*: material discovered by early Greeks that was found to exhibit the effects of electrical charging

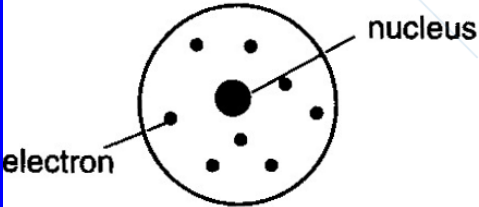
Development of Atomic Models

Model	Characteristics
<p data-bbox="62 491 504 582">Ernest Rutherford's Model (1911)</p>  <p data-bbox="219 829 414 869">Fig. 2.13 (c)</p> 	<p data-bbox="586 494 1803 702">Weakness : The atomic mass calculated using this model is lesser than the actual atomic mass of an element.</p>

Development of Atomic Models

Model

Characteristics

James Chadwick's Model (1932)

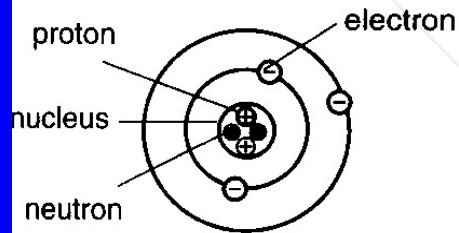
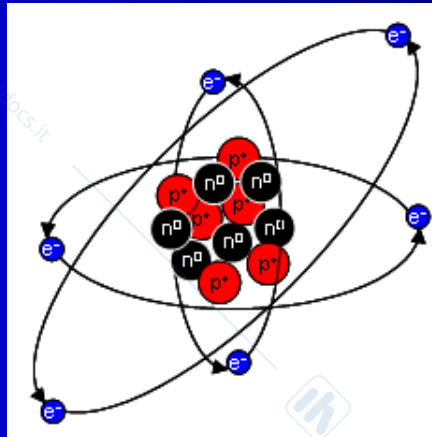

Fig. 2.13 (e)

(a) Solved the weakness of Rutherford's Model when he discovered the presence of neutrons in the nucleus.



Neutrons

- Definition
 - is a neutral subatomic particle that is found in the nucleus of the atom
 - mass almost exactly equal to that of the proton

Comparing Subatomic Particles

Particle	Symbol	Relative Charge	Relative Mass (proton = 1)	Actual Mass (g)
Electron	e^{-}	1^{-}	$\frac{1}{1836}$	9.11×10^{-28}
Proton	p^{+}	1^{+}	1	1.674×10^{-24}
Neutron	n	0	1	1.675×10^{-24}

Nucleus

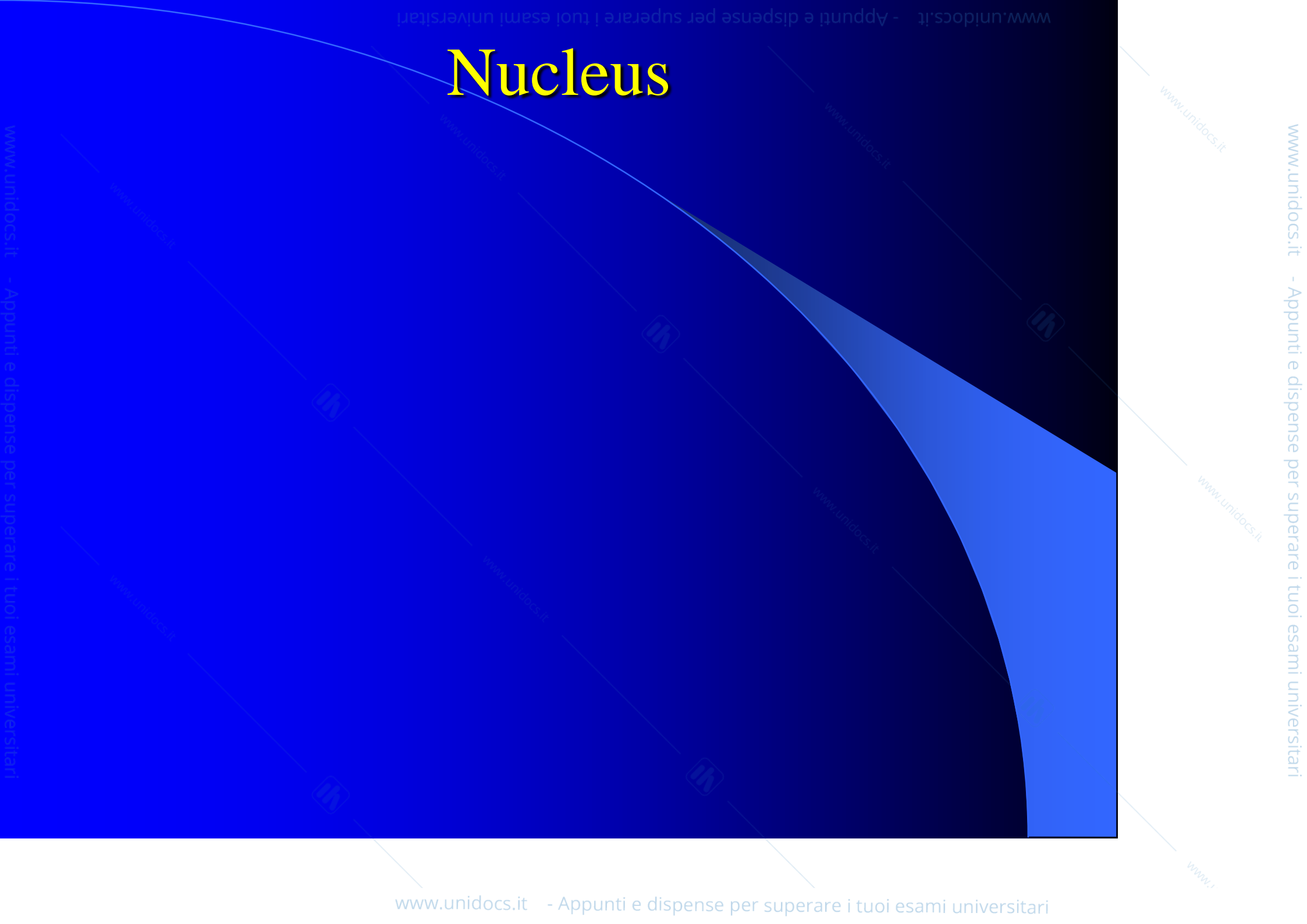

Development of Atomic Models

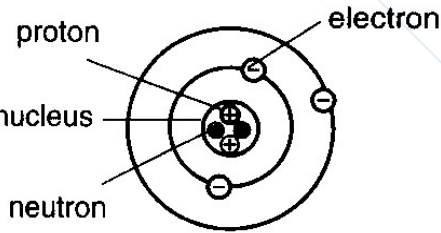
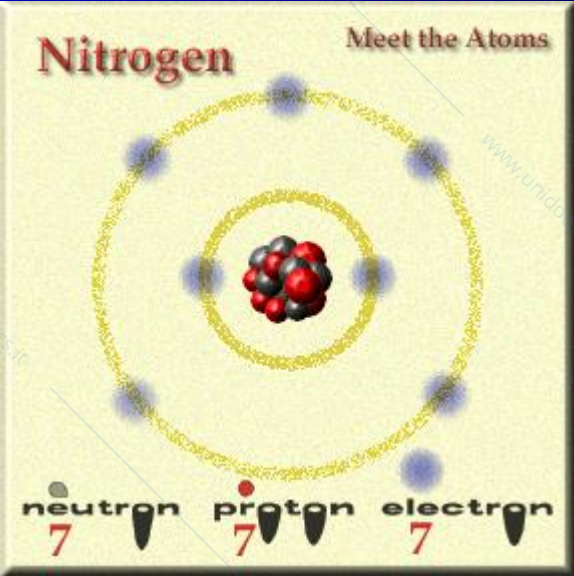
Model	Characteristics
<p data-bbox="78 496 495 580">James Chadwick's Model (1932)</p>  <p data-bbox="230 831 421 871">Fig. 2.13 (e)</p>	<p data-bbox="611 496 1749 676">(c) Stated that all nuclei (singular: nucleus) contained neutrons and protons except for hydrogen, which contained protons only.</p> 



Atomic Number

- Atoms are composed of *identical* protons, neutrons, and electrons
 - How then are atoms of one element different from another element?
- Elements are different because they contain different numbers of PROTONS
- The “**atomic number**” of an element is the number of protons in the nucleus
- # protons in an atom = # electrons

Atomic Number

- Definition
 - number of protons in the atom
 - ex. Oxygen $8p = 8$
 - elements are classified by this number
 - continues up to 119
 - unique to a given element
 - all atoms are electrically neutral, meaning the number of electrons must equal the number of protons
 - this arrangement of elements by their atomic numbers makes up the periodic table
 - Usually located at the upper left hand corner

Atomic Symbols

- each element has its own name, accompanied by a symbol
- usually one/two letters (first is always capitalized)

ex. Iron: Fe

- Fe represents 1 atom of iron,
- 2Fe represents 2 atoms of iron etc...
- can also be written as Fe₂

Atomic Number

Atomic number (Z) of an element is the number of protons in the nucleus of each atom of that element.

Element	# of protons	Atomic # (Z)
Carbon	6	6
Phosphorus	15	15
Gold	79	79

Symbols

- Contain the symbol of the element and the atomic number.

Subscript →

Atomic
number

X

Mass Number

- although a given type of atom will usually contain a certain number of neutrons in the nucleus, a small percentage will not
 - ex. most hydrogen atoms contain no neutrons
- a small percentage contain one neutron and a smaller percentage two neutrons
- What do we call atoms with a different number of neutrons?
 - isotopes

Isotopes

■ Definition

- the number of neutrons in the nucleus of a given element may vary, protons remain the same

ex. H contains 1 protons (^1H)

H contains 1 protons and 1 neutrons
(^2H) deuterium

H contains 1 protons and 2 neutrons
(^3H) tritium

ex. ^{14}C : Carbon-14

Complete Symbols

- Contain the symbol of the element, the mass number and the atomic number.

Superscript →

Mass
number

X

Subscript →

Atomic
number

Mass Number

■ Definition

- the total number of protons and neutrons in the nucleus of an atom

- mass number – atomic number = neutrons

ex. N: mass number of 14

atomic number of 7

7 neutrons

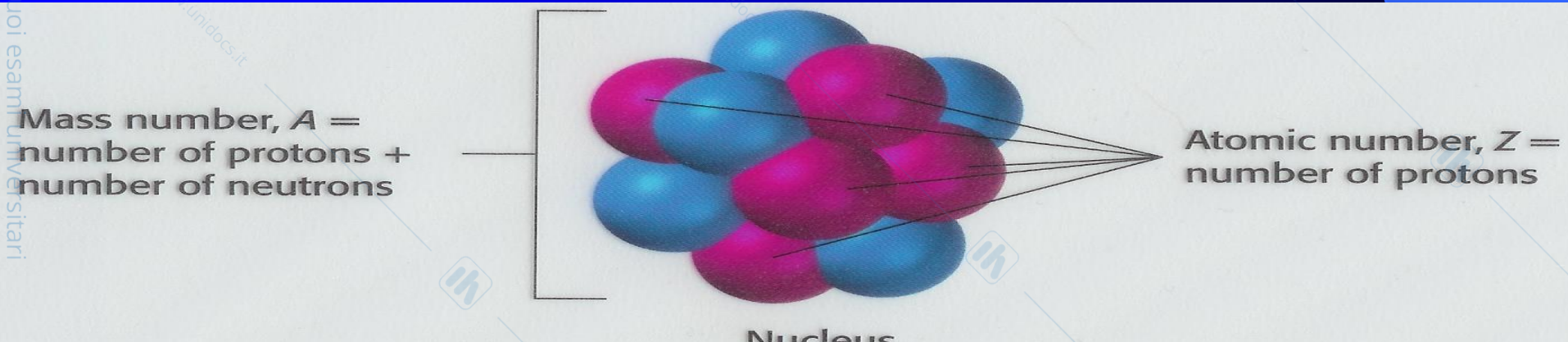

idrogeno ${}^1_1\text{H}$

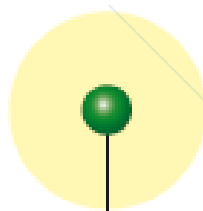

1 protone

deuterio ${}^2_1\text{H}$

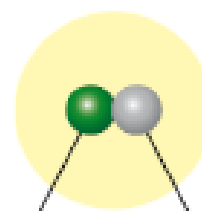

1 protone

1 neutrone

trizio ${}^3_1\text{H}$

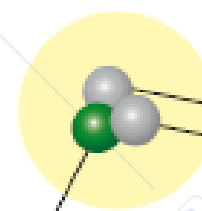



1 protone

2 neutroni

Figura 2.5. I tre nuclidi isotopi dell'idrogeno.

Isotopes are atoms of the **same element** having *different masses*, due to varying numbers of neutrons.

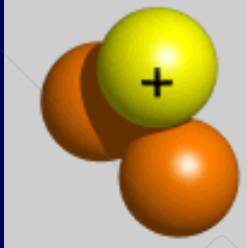
Isotope	Protons	Electrons	Neutrons	Nucleus
Hydrogen-1 (protium)	1	1	0	
Hydrogen-2 (deuterium)	1	1	1	
Hydrogen-3 (tritium)	1	1	2	

Mass Number

Mass number is the number of protons and neutrons in the nucleus of an isotope:

$$\text{Mass \#} = p^+ + n^0$$

Nuclide	p^+	n^0	e^-	Mass #
$^{18}\text{Oxygen}$	8	10	8	18
$^{75}\text{Arsenic}$	33	42	33	75
$^{31}\text{Phosphorus}$	15	16	15	31

Isotopes

- 5 Table 2.2 below shows several isotopes:

Element	Name of Isotopes		Protons	Neutrons	Proton number	Nucleon number
Hydrogen	Hydrogen - 1 (protium)	${}^1_1\text{H}$	1	0	1	1
	Hydrogen - 2 (deuterium)	${}^2_1\text{H}$	1	1	1	2
	Hydrogen - 3 (tritium)	${}^3_1\text{H}$	1	2	1	3
Carbon (3 isotopes)	Carbon - 12	${}^{12}_6\text{C}$	6	6	6	12
	Carbon - 13	${}^{13}_6\text{C}$	6	7	6	13
	Carbon - 14	${}^{14}_6\text{C}$	6	8	8	14
Oxygen (3 isotopes)	Oxygen - 16	${}^{16}_8\text{O}$	8	8	8	16
	Oxygen - 17	${}^{17}_8\text{O}$	8	9	8	17
	Oxygen - 18	${}^{18}_8\text{O}$	8	10	8	18
Chlorine (2 isotopes)	Chlorine - 35	${}^{35}_{17}\text{Cl}$	17	18	17	35
	Chlorine - 37	${}^{37}_{17}\text{Cl}$	17	20	17	37
Bromine (2 isotopes)	Bromine - 79	${}^{79}_{35}\text{Br}$	35	44	35	79
	Bromine - 81	${}^{81}_{35}\text{Br}$	35	46	35	81



Same



Different



Same



Different

Isotopes

- Isotopes of a particular element have **different physical** properties because they have a different number of neutrons in each. Thus their densities and boiling points are different.

Isotopes

Elements occur in nature as mixtures of **isotopes**.

Isotopes are atoms of the same element that differ in the *number of neutrons*.

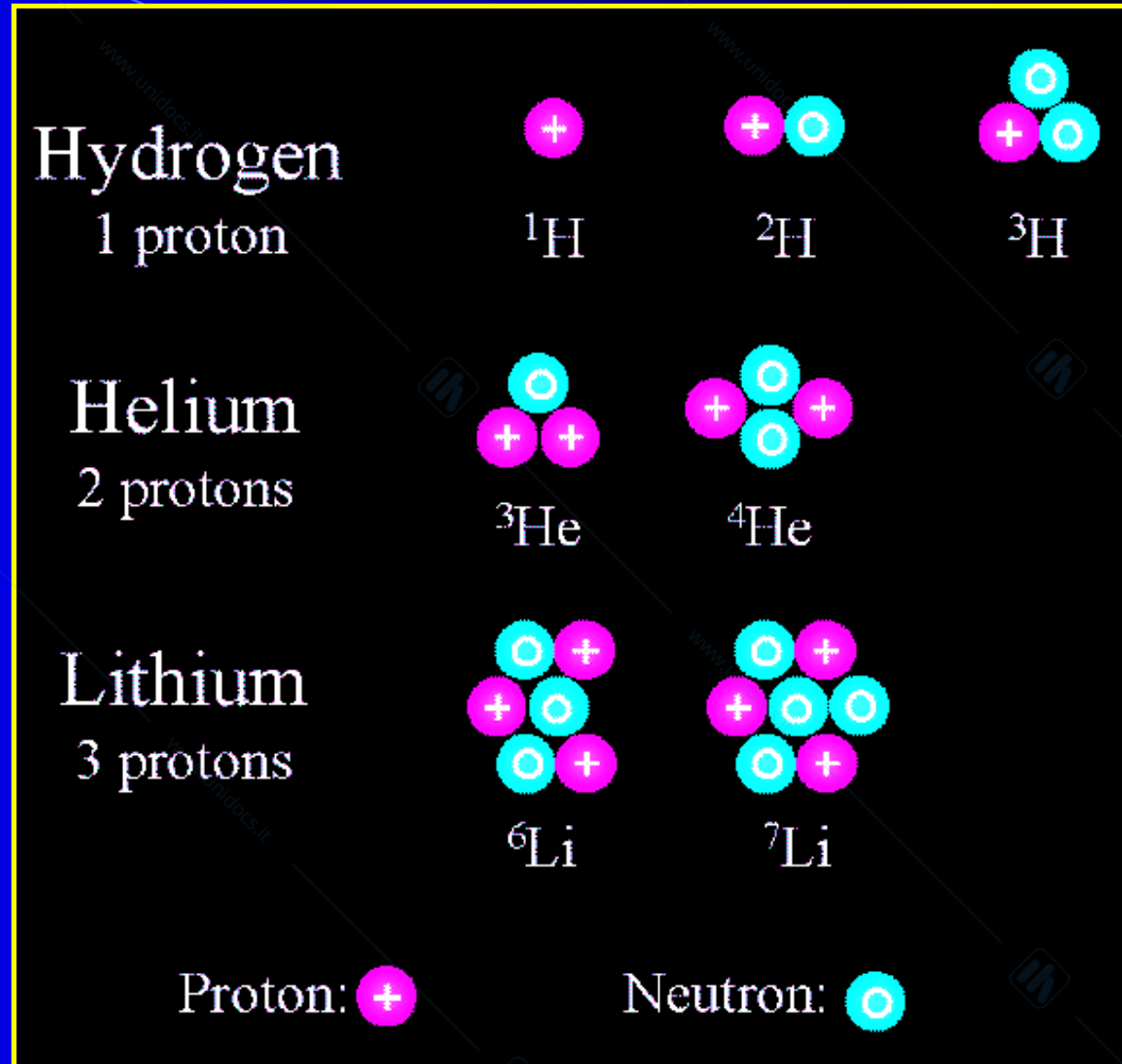

Isotopes

- the number of neutrons in the nucleus of a given element may vary, protons remain the same

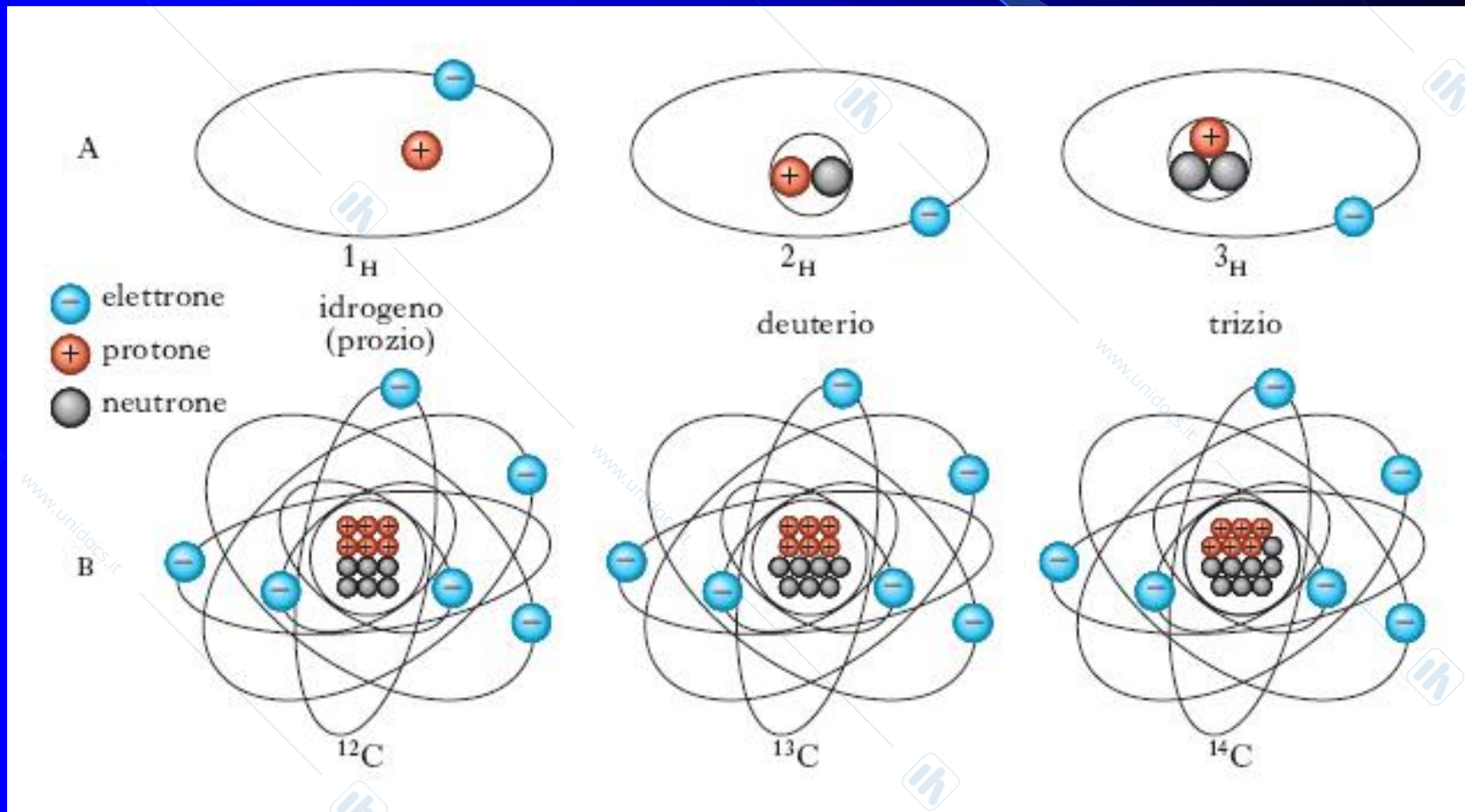

${}^1\text{H}$

${}^{12}\text{C}$

Atomic Mass

Atomic mass is the

- Mass of a single atom in atomic mass units (amu).
- Mass of an atom compared to a ^{12}C atom.
- Number below the symbol of an element.

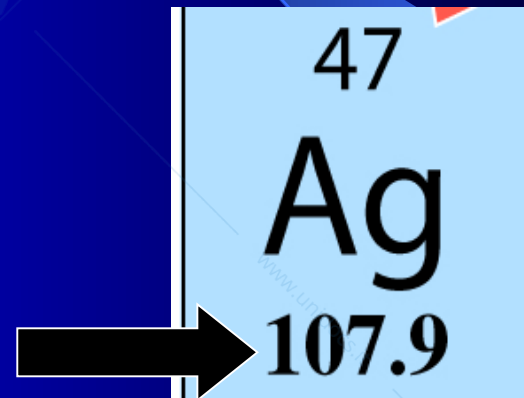

Relative atomic mass, A_r

- The relative atomic mass of an element is the average mass of one atom of the element when compared with $1/12$ of the mass of a carbon -12.

Atomic Mass

- AMU or the Dalton (Da)
 - equal to $1.6605402 \times 10^{-27}$ kg

Relative atomic mass, A_r

- If more than one isotope of element is present, the atomic mass is calculated by taking the average of the relative atomic masses of different isotopes.

Examples of isotopes of some elements

Element	Proton number	Nucleon number	Number of protons	Number of neutrons	Percentage abundance
Hydrogen, ${}^1_1\text{H}$	1	1	1	0	99.985%
Deuterium, ${}^2_1\text{H}$	1	2	1	1	0.015%
Tritium, ${}^3_1\text{H}$	1	3	1	2	Man-made isotope
Carbon-12, ${}^{12}_6\text{C}$	6	12	6	6	98.1%
Carbon-13, ${}^{13}_6\text{C}$	6	13	6	7	1.1%
Carbon-14, ${}^{14}_6\text{C}$	6	14	6	8	0.8 %
Chlorine-35, ${}^{35}_{17}\text{Cl}$	17	35	17	18	75.5%
Chlorine-37, ${}^{37}_{17}\text{Cl}$	17	37	17	20	24.5%
Oxygen-16, ${}^{16}_8\text{O}$	8	16	8	8	99.757%
Oxygen-17, ${}^{17}_8\text{O}$	8	17	8	9	0.038%
Oxygen-18, ${}^{18}_8\text{O}$	8	18	8	10	0.205%

Calculating Atomic Mass

- Percent(%) abundance of isotopes
- Mass of each isotope of that element
- Weighted average =

$$\frac{\text{mass isotope}_1(\%)}{100} + \frac{\text{mass isotope}_2(\%)}{100} + \dots$$

100

100

Atomic Mass of Magnesium

Isotopes	Mass of Isotope	Abundance
^{24}Mg =	24.0 amu	78.70%
^{25}Mg =	25.0 amu	10.13%
^{26}Mg =	26.0 amu	11.17%

Atomic mass (average mass) Mg = 24.3 amu

Mg
24.3



Nuclear Stability

- There are very large repulsive electrostatic forces between protons
 - These forces should cause the nucleus to fly apart
- The nuclei are stable because of the presence of another, short-range force, called the *nuclear force*
 - This is an attractive force that acts between all nuclear particles
 - The nuclear attractive force is stronger than the Coulomb repulsive force at the short ranges within the nucleus



Figura 1. La somma delle masse dei singoli nucleoni componenti un nucleo atomico è leggermente superiore a quella del nucleo preso nel suo complesso.

Binding Energy

- The total energy of the bound system (the nucleus) is less than the combined energy of the separated nucleons
 - This difference in energy is called the *binding energy* of the nucleus
 - It can be thought of as the amount of energy you need to add to the nucleus to break it apart into separated protons and neutrons

- The dots indicate stable nuclei, which group in a band of stability according to their neutron-to-proton ratio. As the size of nuclei increases, so does the neutron-to-proton ratio that represents stability. Nuclei outside this band of stability are radioactive.

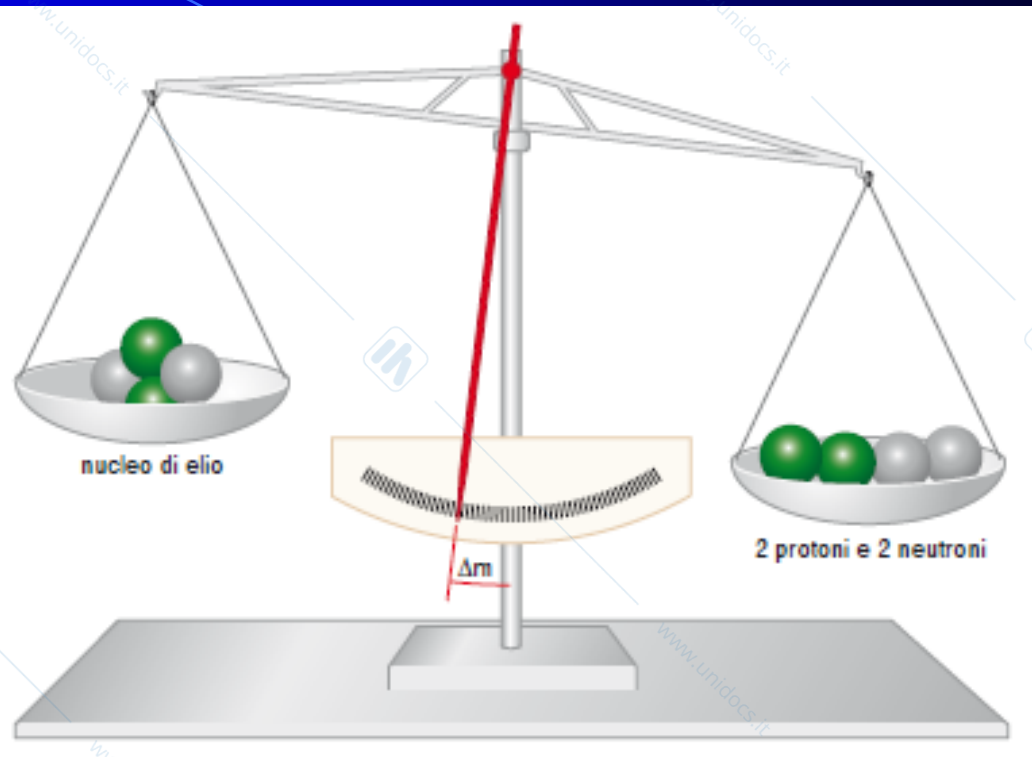
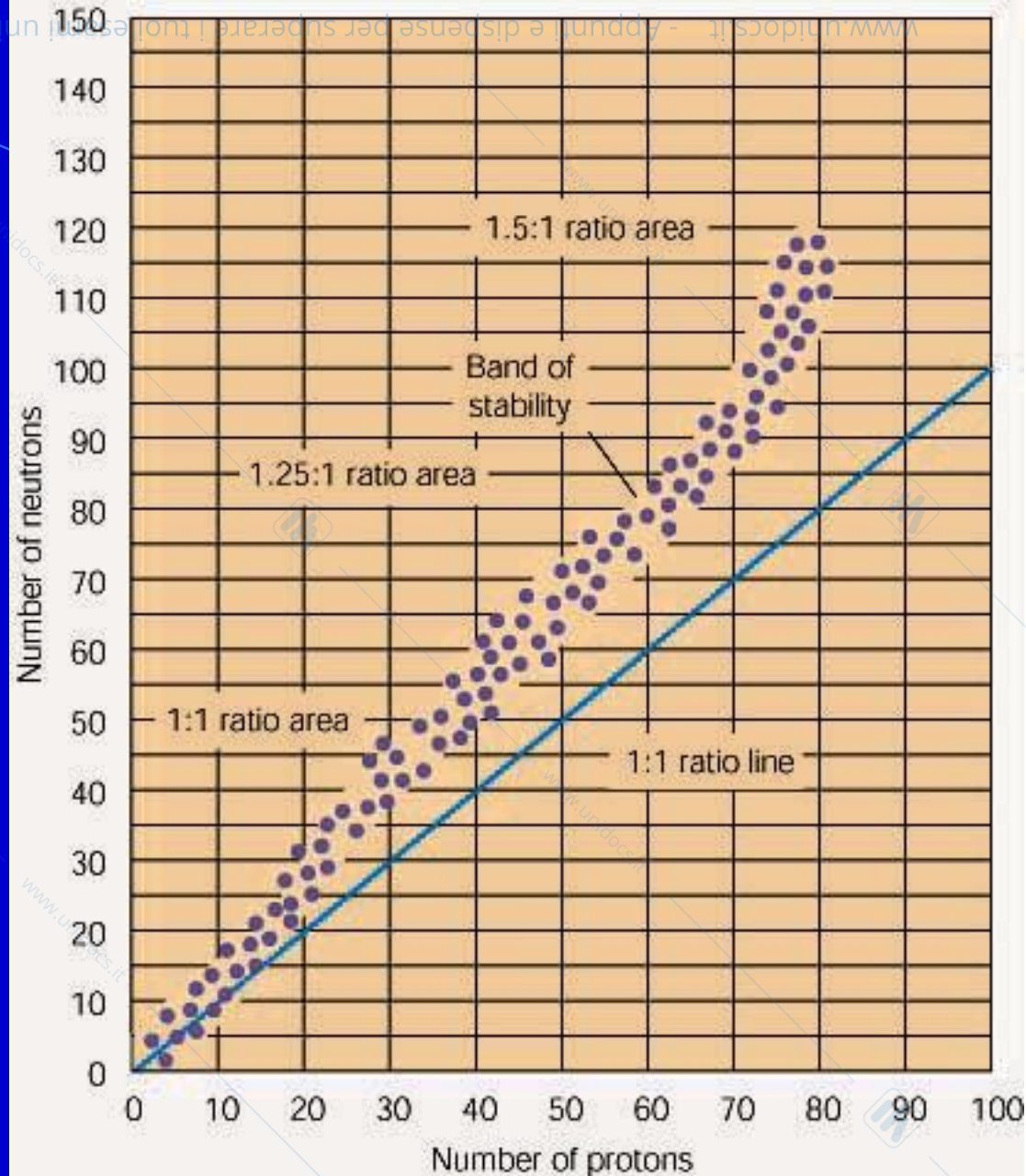

- Unstable nuclei undergo different types of radioactive decay to obtain a more stable nucleus. The type of decay depends, in general, on the neutron-to-proton ratio, as shown.

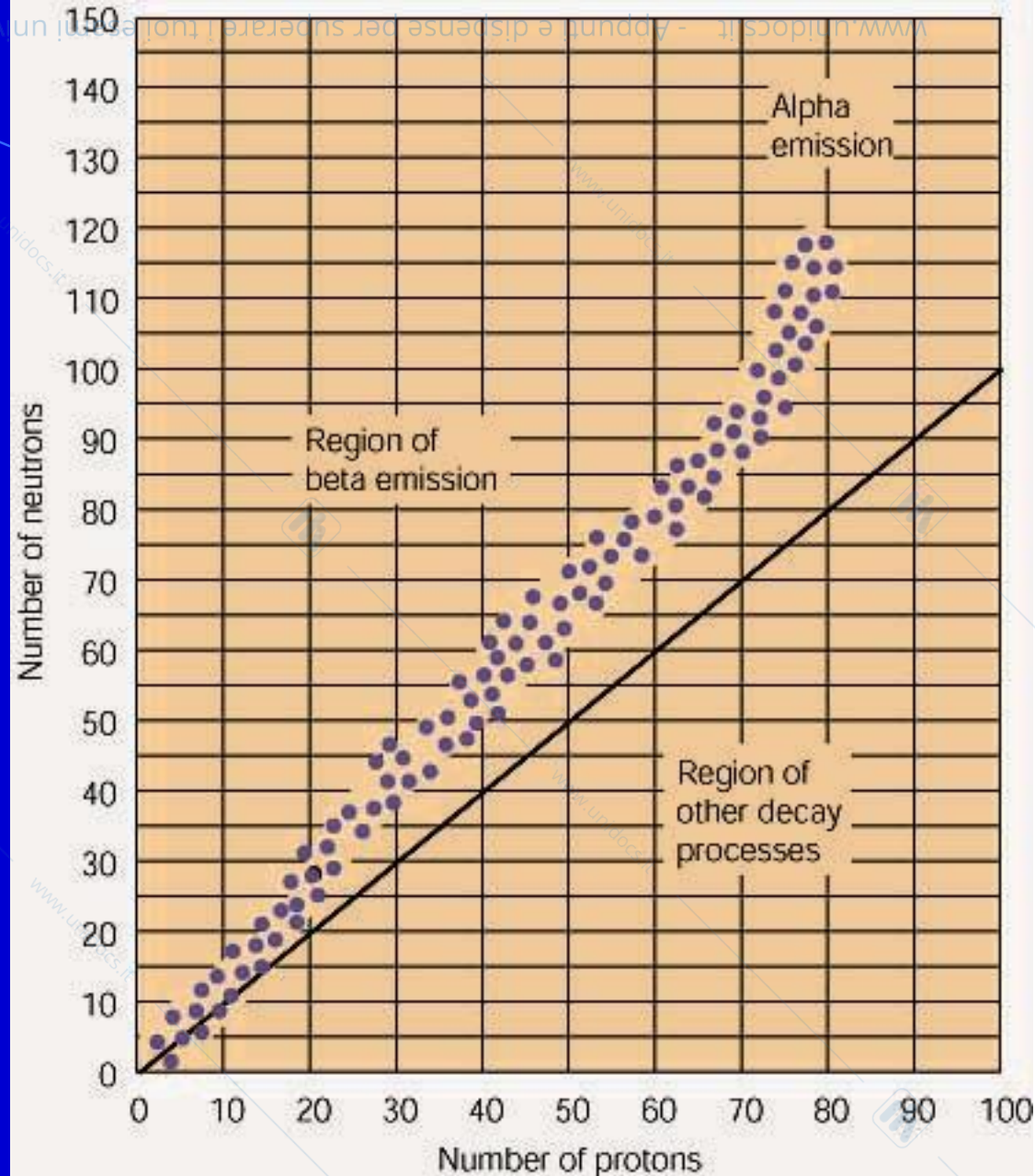

- The rate of radioactive decay is expressed in terms of half-life
 - The **half-life** of an element is the time required from one-half of its unstable nuclei to decay
 - The half-life of an element is related to the ratio of 0.693 to its radioactive decay constant
 - $t_{1/2} = 0.693/k$
 - The **decay constant** for ^{238}U is $4.87 \times 10^{-18}/\text{s}$
 - The half life is therefore
 - $t_{1/2} = 4.5 \times 10^9$ years
 - The half-life of ^{238}U is 4.5 billion years.

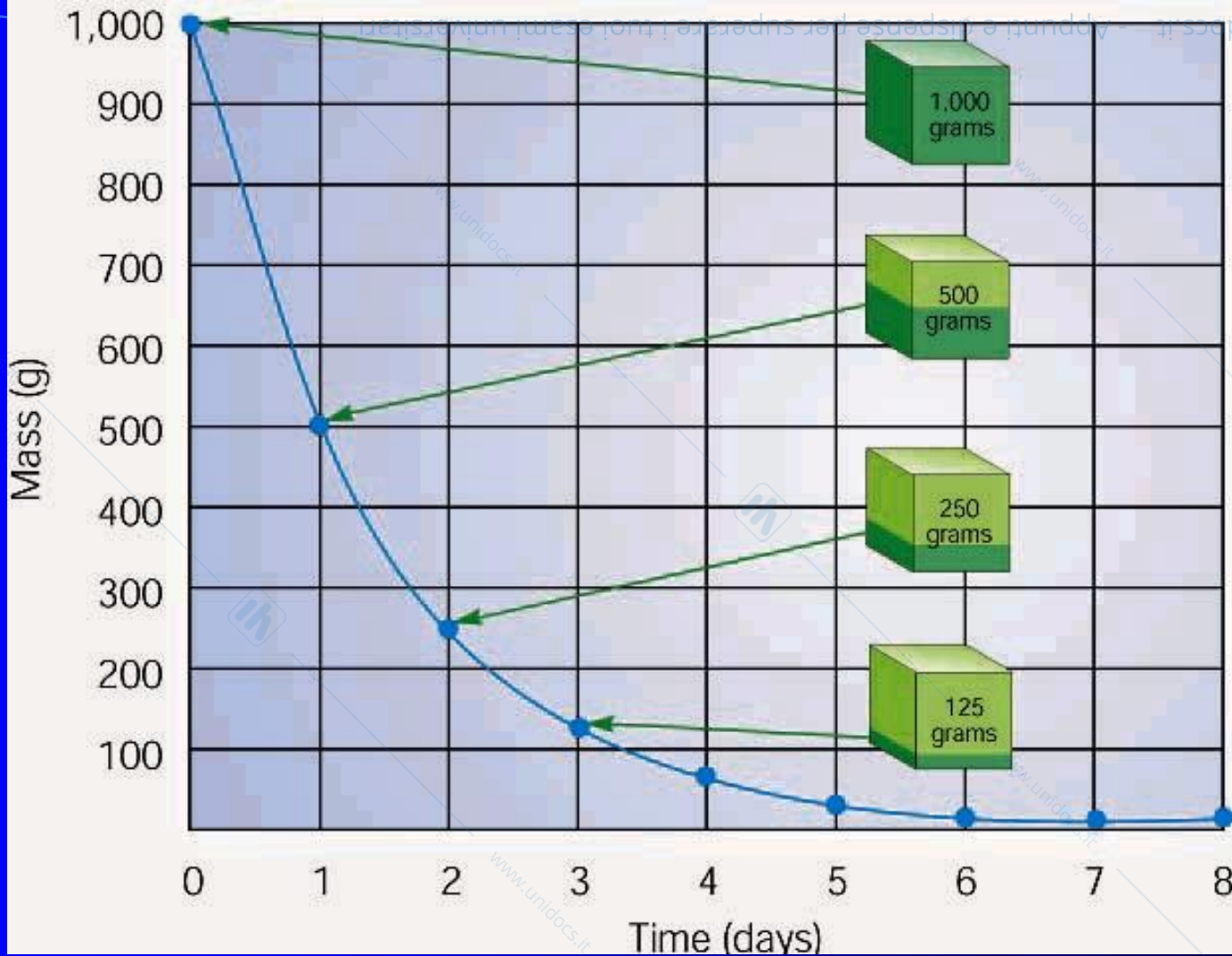

- Radioactive decay of a hypothetical isotope with a half-life of one day. The sample decays each day by one-half to some other element. Actual half-lives may be in seconds, minutes, or any time unit up to billions of years.

Radiation and Radioactivity



- ◆ Radiation: Energy in transit, either as particles or electromagnetic waves
- ◆ Radioactivity: The characteristic of various materials to emit ionizing radiation
- ◆ Ionization: The removal of electrons from an atom. The essential characteristic of high energy radiations when interacting with matter.

Radiation

is energy in transit in the form of **high speed particles and electromagnetic waves**.

Ionizing radiation

is radiation **with enough energy** so that during an interaction with an atom, it can remove tightly bound electrons from their orbits, causing the atom to become charged or ionized (examples: gamma rays, neutrons)

Non-ionizing radiation

is radiation **without enough energy** to to separate molecules or remove electrons from atoms. Examples are visible light, radio and television waves, ultra violet (UV), and microwaves with a large spectrum of energies.

Common Types of Radiation

Alphas

An alpha is a particle emitted from the nucleus of an atom, that contains **2 protons and 2 neutrons**. It is identical to the nucleus of a Helium atom, without the electrons.

Betas

A beta is a high speed particle, identical to an electron, that is emitted **from the nucleus** of an atom

Gamma Rays

Gamma rays are **electromagnetic waves / photons** emitted **from the nucleus** (center) of an atom.

X rays

X Rays are **electromagnetic waves / photons** emitted **not from the nucleus**, but normally emitted **by energy changes in electrons**. These energy changes are either in electron orbital shells that surround an atom or in the process of slowing down such as in an X-ray machine.

Neutrons

Neutrons are **neutral particles** that are normally contained in the nucleus of all atoms and may be removed **by various interactions or processes like collision and fission**

Alpha Particle Radiation

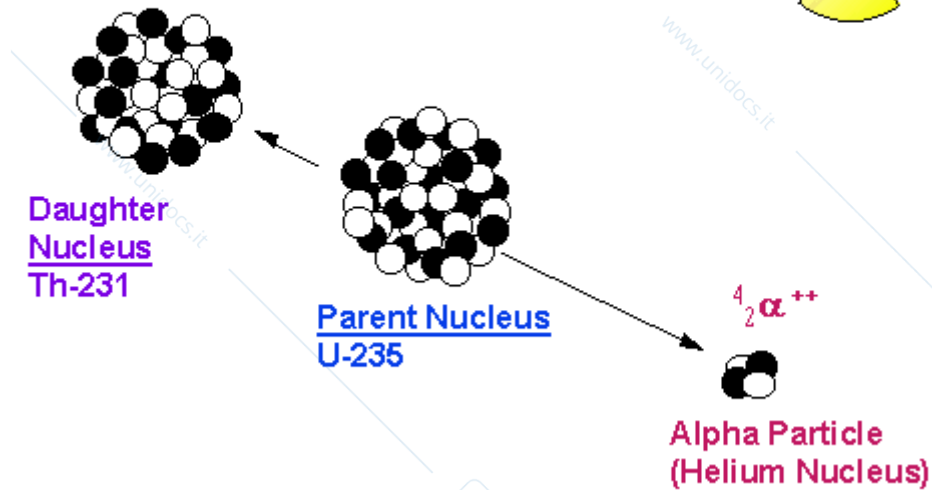

Alpha decay is a radioactive process in which a particle with **two neutrons and two protons** is ejected from the nucleus of a radioactive atom. The particle is identical to the nucleus of a **helium atom**.

Alpha decay only occurs **in very heavy elements** such as uranium, thorium and radium. The nuclei of these atoms are very “neutron rich” (i.e. have a lot more neutrons in their nucleus than they do protons) which makes emission of the alpha particle possible.

After an atom ejects an alpha particle, a new parent atom is formed which has two less neutrons and two less protons. Thus, when uranium-238 (which has a Z of 92) decays by alpha emission, thorium-234 is created (which has a Z of 90).

Because alpha particles contain two protons, they have a positive charge of two. Further, alpha particles are very heavy and very energetic compared to other common types of radiation. Typical alpha particles will **travel no more than a few centimeters in air** and are stopped by a sheet of paper.

Alpha Decay

- When a nucleus emits an alpha particle it loses two protons and two neutrons
 - N decreases by 2
 - Z decreases by 2
 - A decreases by 4
- Symbolically
 - X is called the *parent nucleus*
 - Y is called the *daughter nucleus*



Beta Particle Radiation

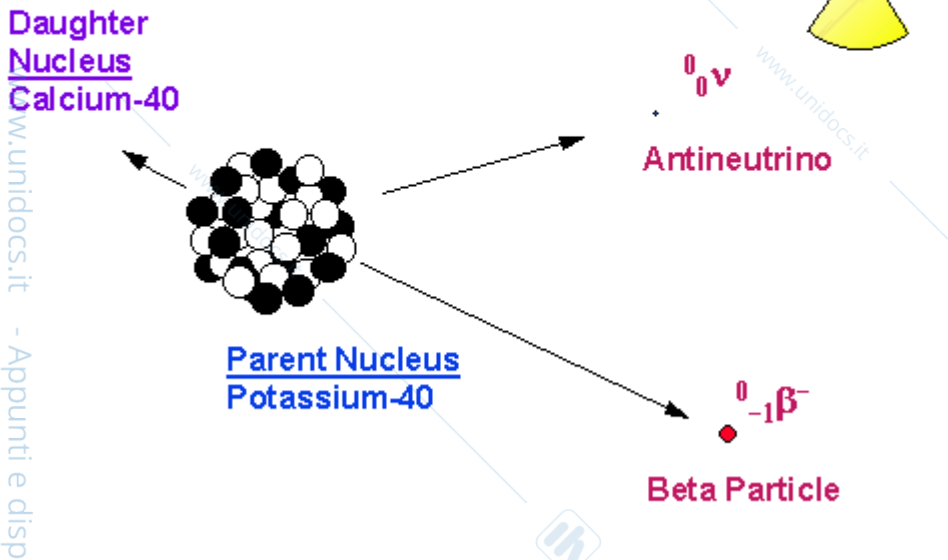

Beta decay is a radioactive process in which an **electron is emitted from the nucleus** of a radioactive atom, along **with** an unusual particle called an **antineutrino** (almost massless particle that carries away some of the energy).

Like alpha decay, beta decay occurs in isotopes which are “**neutron rich**” .

When a nucleus ejects a beta particle, **one of the neutrons in the nucleus is transformed into a proton**.

Beta particles have a **single negative charge** and weigh only a small fraction of a neutron or proton. As a result, beta particles interact less readily with material than alpha particles. Beta particles will **travel up to several meters in air**, and are stopped by thin layers of metal or plastic.

Beta Decay

- During beta decay, the daughter nucleus has the same number of nucleons as the parent, but the atomic number is changed by one
- Symbolically



Pure β^- (Negatron) Emission

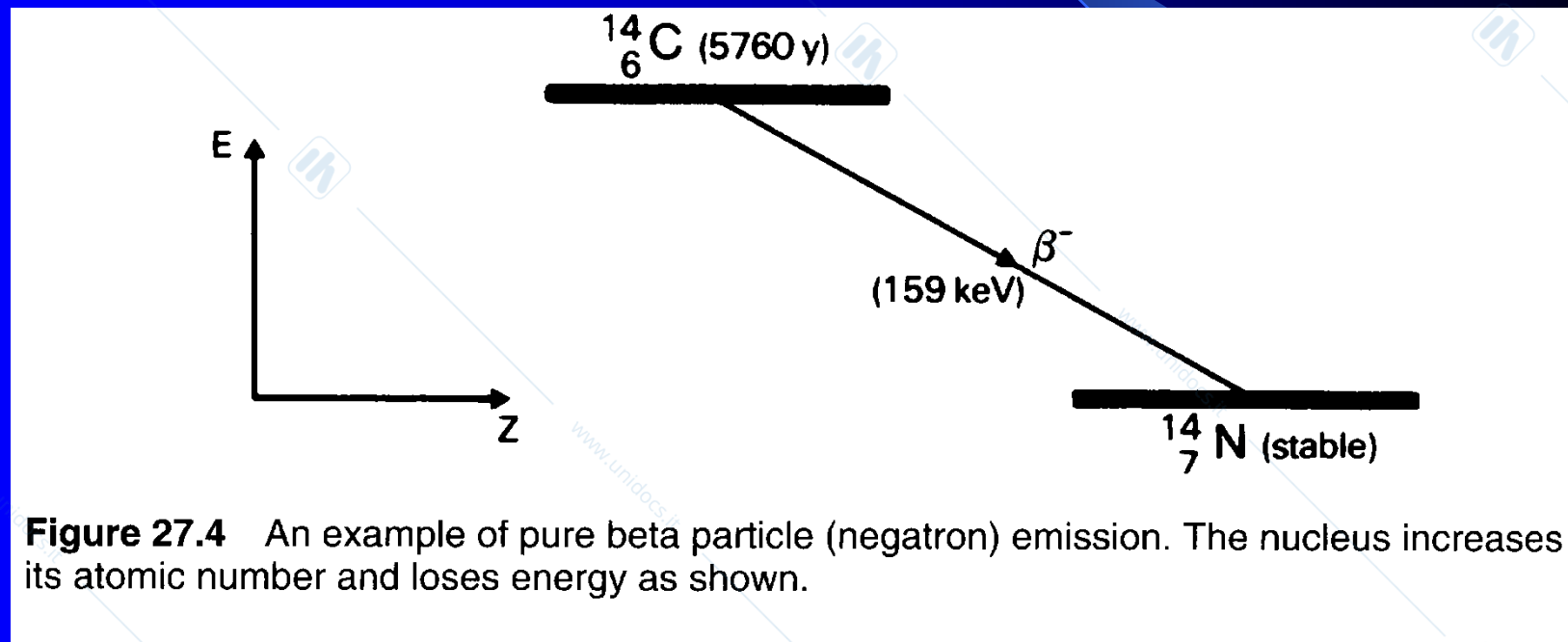

Figure 27.4 An example of pure beta particle (negatron) emission. The nucleus increases its atomic number and loses energy as shown.

Positron β^+ Emission

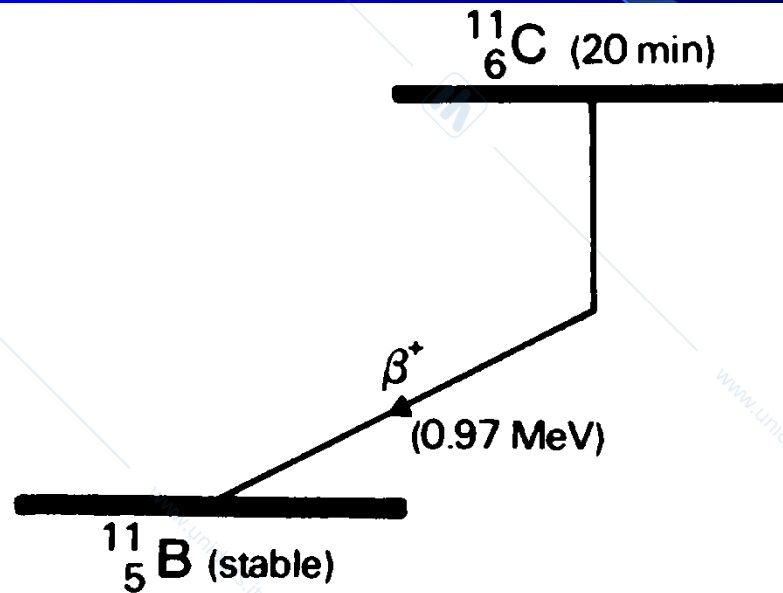

Figure 27.6 An example of positron decay. The nucleus experiences a decrease in the atomic number and loses energy as shown.

Gamma decay

After a decay reaction, the nucleus is often in an “excited” state. This means that the decay has resulted in producing a nucleus which still has excess energy to get rid of. Rather than emitting another beta or alpha particle, this energy is lost by **emitting a pulse of electromagnetic radiation** called a gamma ray. **The gamma ray is identical in nature to light or microwaves, but of very high energy.**

Like all forms of electromagnetic radiation, the gamma ray has **no mass and no charge**. Gamma rays interact with material by colliding with the electrons in the shells of atoms. They lose their energy slowly in material, being able to **travel significant distances** before stopping. Depending on their initial energy, gamma rays can travel from 1 to **hundreds of meters in air and can easily go right through people.**

It is important to note that most alpha and beta emitters also emit gamma rays as part of their decay process. However, there is no such thing as a “pure” gamma emitter.



The Uses of Isotopes

- 2 The radioisotopes emit alpha rays, beta rays and gamma rays, which are used for various purposes in the various fields.

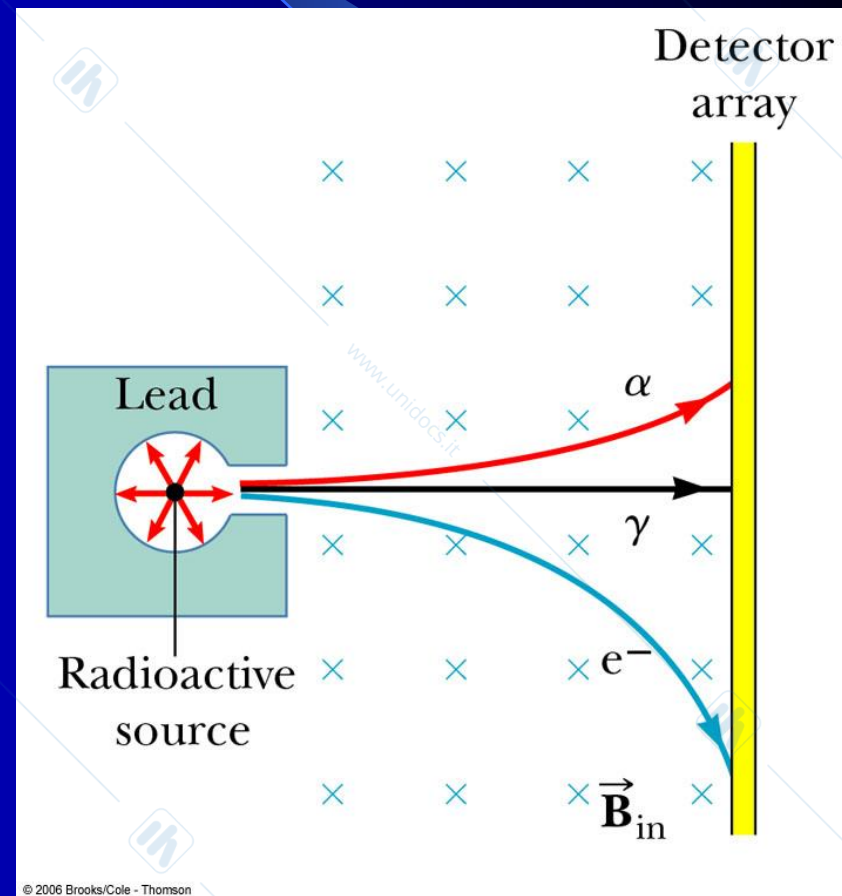

Properties of Radiation

Alpha particles are heavy and doubly charged which cause them to lose their energy very quickly in matter. They can be **shielded** by a sheet of paper or the **surface layer of our skin**. Alpha particles are considered **hazardous only to a person's health if an alpha emitting material is ingested or inhaled**.

Beta and positron particles are much smaller and only have one charge, which cause them to interact more slowly with material. They are effectively shielded by thin layers of metal or plastic and are again considered **hazardous only if a beta emitter is ingested or inhaled**.

Gamma emitters are associated with alpha, beta, and positron decay. X-Rays are produced either when electrons change orbits within an atom, or electrons from an external source are deflected around the nucleus of an atom. Both are forms of high energy electromagnetic radiation which **interact lightly with matter**. X-rays and gamma rays are best **shielded by thick layers of lead or other dense material** and are **hazardous to people when they are external to the body**.

Neutrons are neutral particles with approximately the same mass as a proton. Because they are neutral they **react only weakly with material**. They are an external hazard best **shielded by thick layers of concrete**.

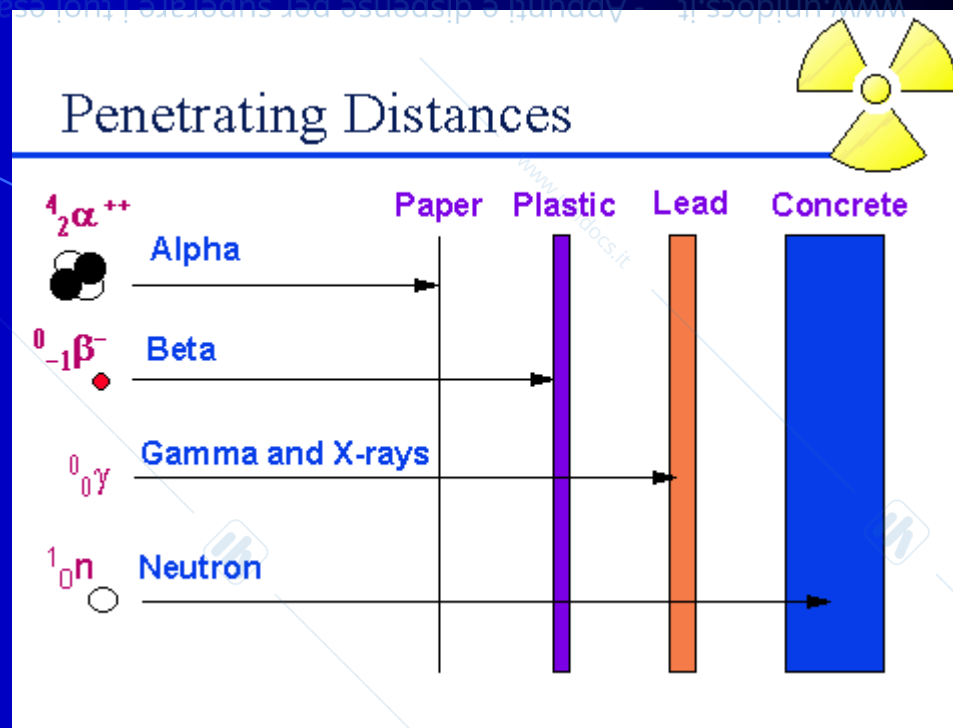

The Uses of Isotopes

1 Many isotopes which are used in the medical, industrial and agricultural fields involve **radioactive** elements. These isotopes are called **radioisotopes**.



Main advantages of this method are :

Radioactive isotopes introduced into an organism are distinguishable by their radiation from the atoms already present. This permits the relatively simple acquisition of information about the dynamics of processes of uptake, incorporation, exchange, secretion, etc.

The tracer method is extremely sensitive. In principle even the presence of only one atom can be detected.

The high sensitivity allows the study of various processes with amounts of substances so small that they have no influence on the life processes.

“In vivo methods”

- 1) labeled molecules and compounds, which behave virtually identically to the unlabelled ones in the various chemical, biochemical and biological processes
- 2) radioactive isotopes form compounds in the same way like as the stable isotopes
- 3) isotopes disclose their presence by their radiation, and thus their movement and fate can be traced
- 4) For these purposes are used radionuclides that emit electromagnetic waves (γ rays) but don't emit any particle (α , β or **neutron**).

Radiopharmaceuticals

- the most widely used radioisotope is Tc, with a half-life of six hours.
- activity in the organ can then be studied either as a two dimensional picture or, with a special technique called tomography, as a three dimensional picture (SPECT, PET)

The Uses of Isotopes

- Medical
- (a) Radioisotopes can be used to identify **tumours** in the body of the person as the radioactive substance collects in the tumour and shown on the Geiger-Muller counter.



The Uses of Isotopes

- **Medical**
- (d) Iodine-131 can be injected into the **thyroid gland** of patient with hyperthyroidism (over-active thyroid gland) to destroy the hyperactive thyroid cells.

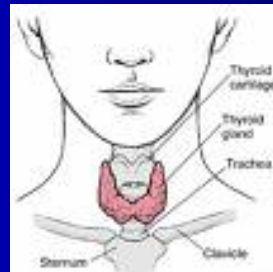



Nuclear medicine: diagnosis

- The common technique used in diagnosis is inserting radioactive tracers into the body, either by inhalation, injection, or orally, that emit **gamma rays** from within the body and accumulate around target tissue.
- A PET (Positron Emission Tomography) scan is then performed that uses isotopes produced in a cyclotron.
- **The radioactive tracers** team with nearby electrons to produce an emission of two gamma rays in opposite directions which helps the PET camera to produce specific indication of their origin.

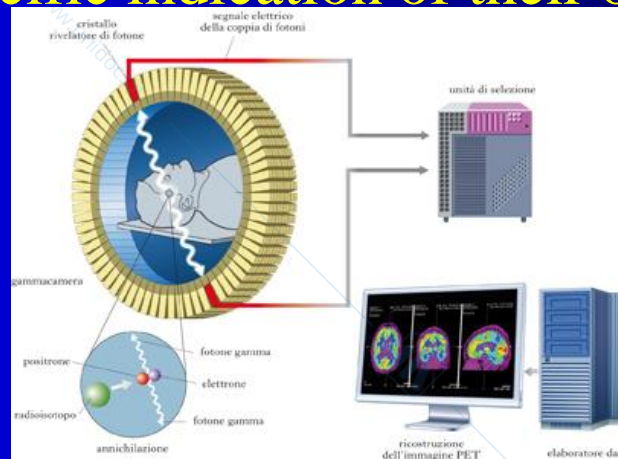



Nuclear medicine

Positron Emission Tomography

La PET-TC è un'apparecchiatura in cui vengono combinate sia l'attività metabolica rivelata con la PET sia quella anatomica rappresentata dalla tomografia computerizzata (TC)

I positroni derivano da radionuclidi instabili (radiofarmaci).
Il positrone tende a combinarsi con un elettrone della materia circostante e la conseguente collisione culmina con la generazione di due fotoni.

La diagnostica PET si basa sulla rilevazione contemporanea di questi due fotoni (raggi gamma), che si comportano quindi come traccianti di un particolare fenomeno biologico

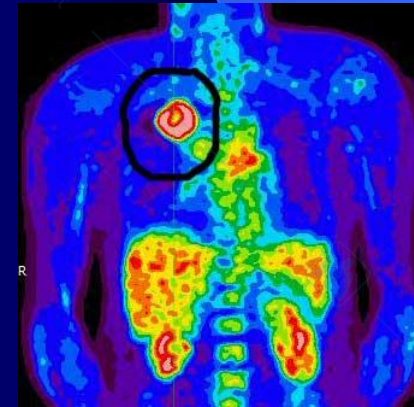

Nucleus reload...

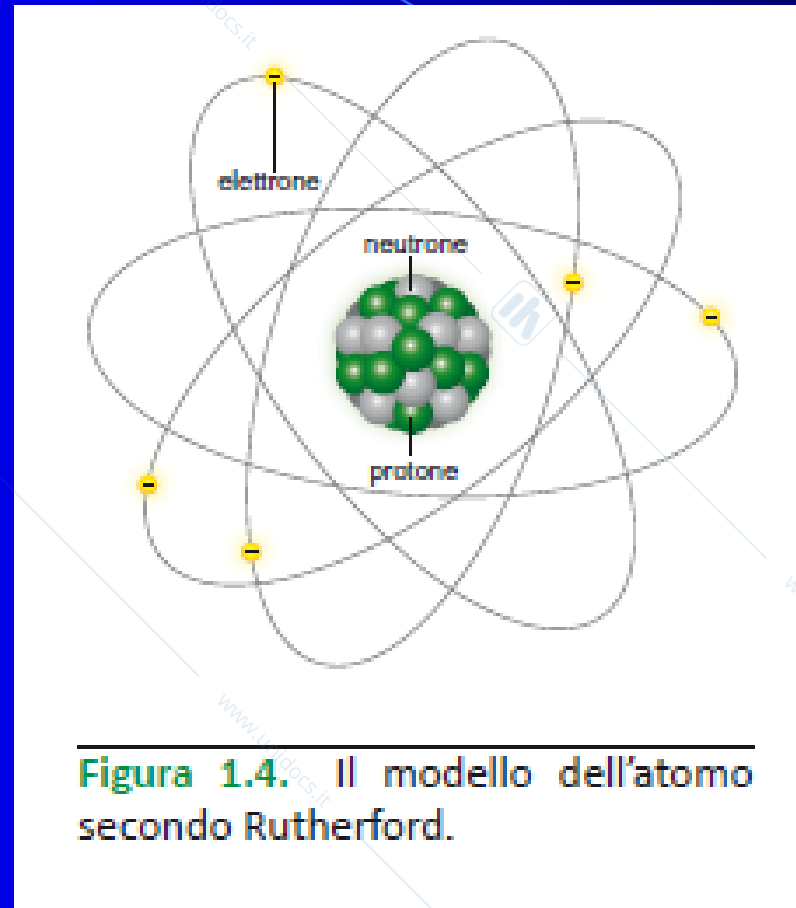

RUTHERFORD'S MODEL OF ATOM

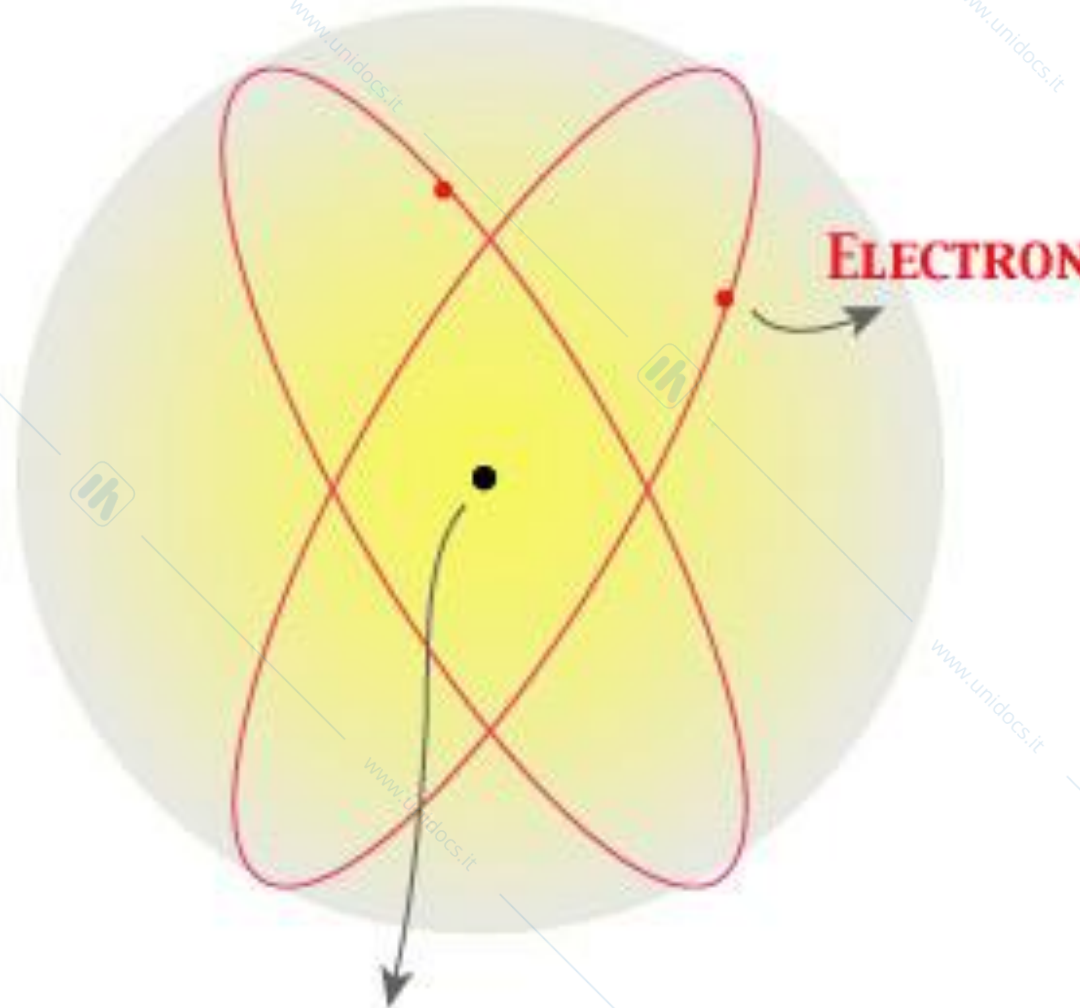

**NUCLEUS, ABOUT THE SIZE OF 1/5000
OF THE WHOLE ATOM**

One view of atomic structure in early 20th century was that an electron (e^-) traveled about the nucleus in an orbit.

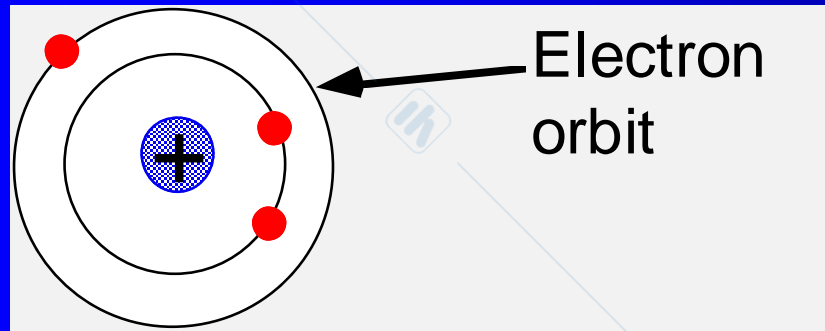

1. Classically any orbit should be possible and so is any energy.

2. But a charged particle moving in an electric field should emit energy.

End result should be destruction!

Niels Bohr

(Born in Denmark 1885-1962)

- Student of Rutherford

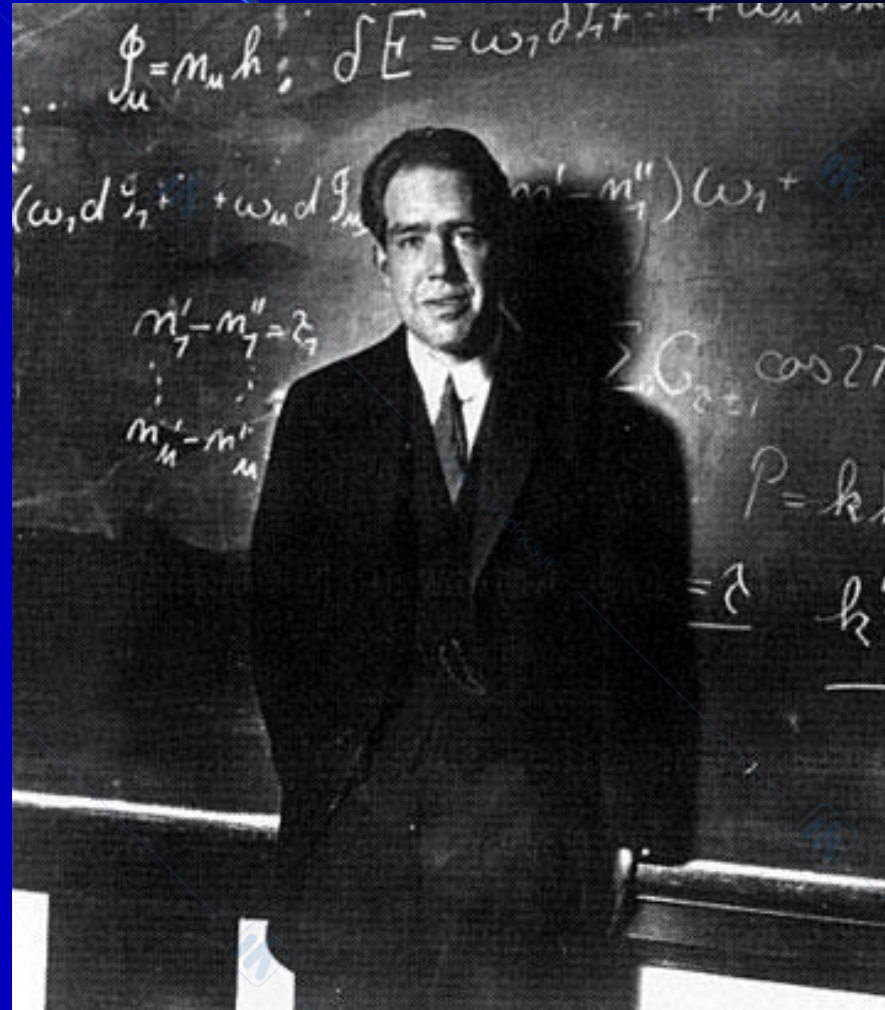

Atomic Line Spectra

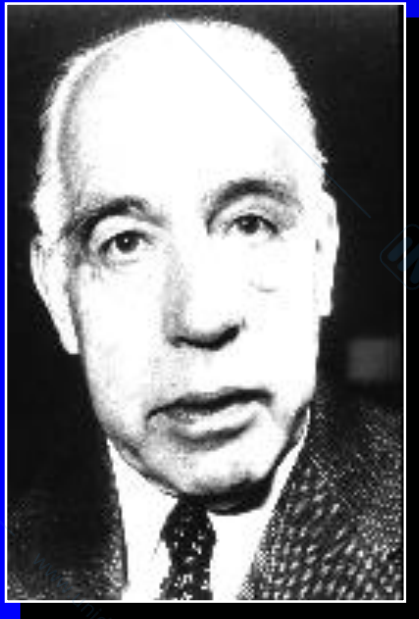

Niels Bohr (1885-1962)
(Nobel Prize, 1922)

- Bohr's greatest contribution to science was in building a simple model of the atom.
- It was based on understanding the **SHARP LINE SPECTRA** of excited atoms.

Obtaining a Line Spectrum

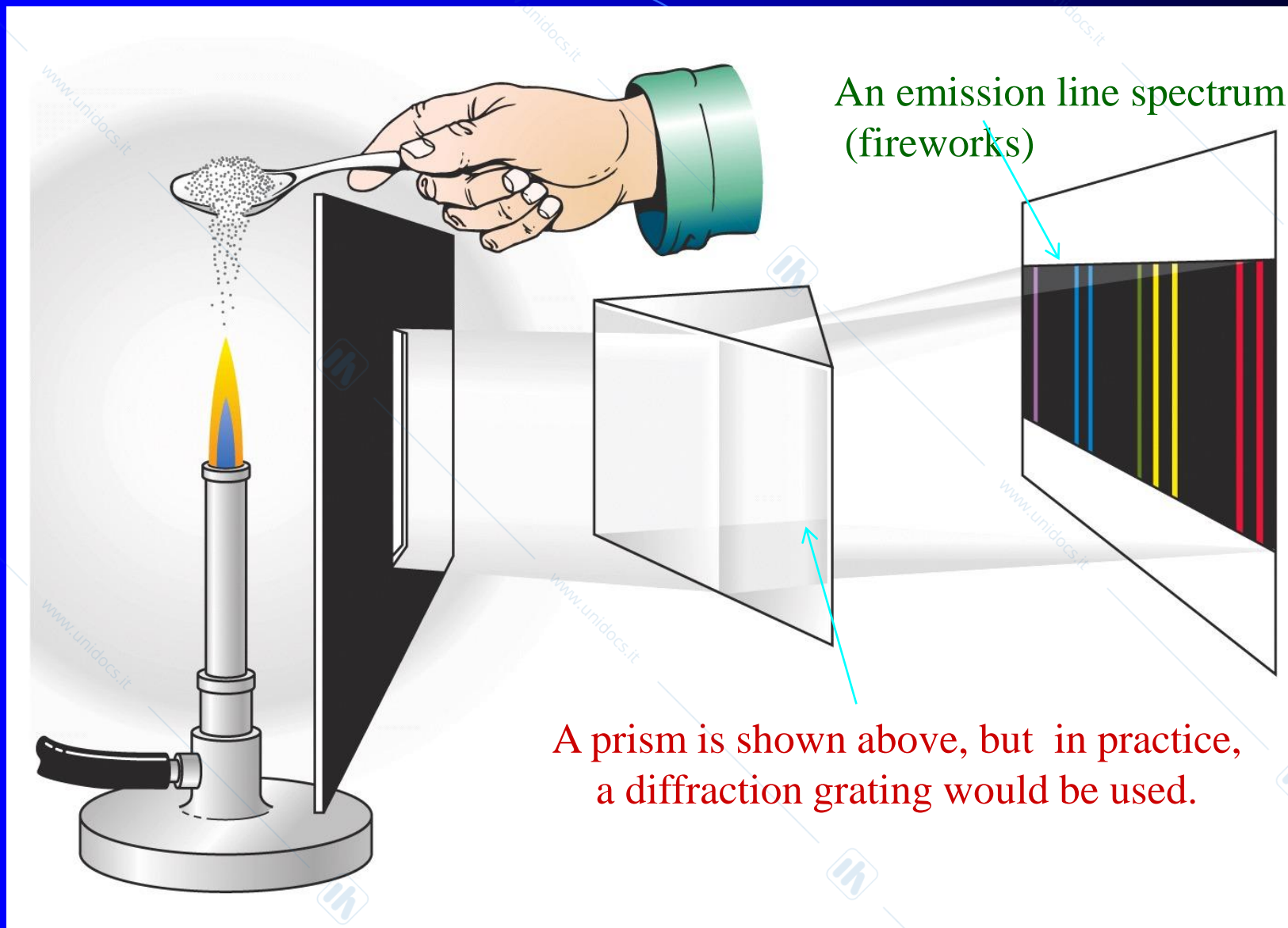

Emission & Absorption Spectrum

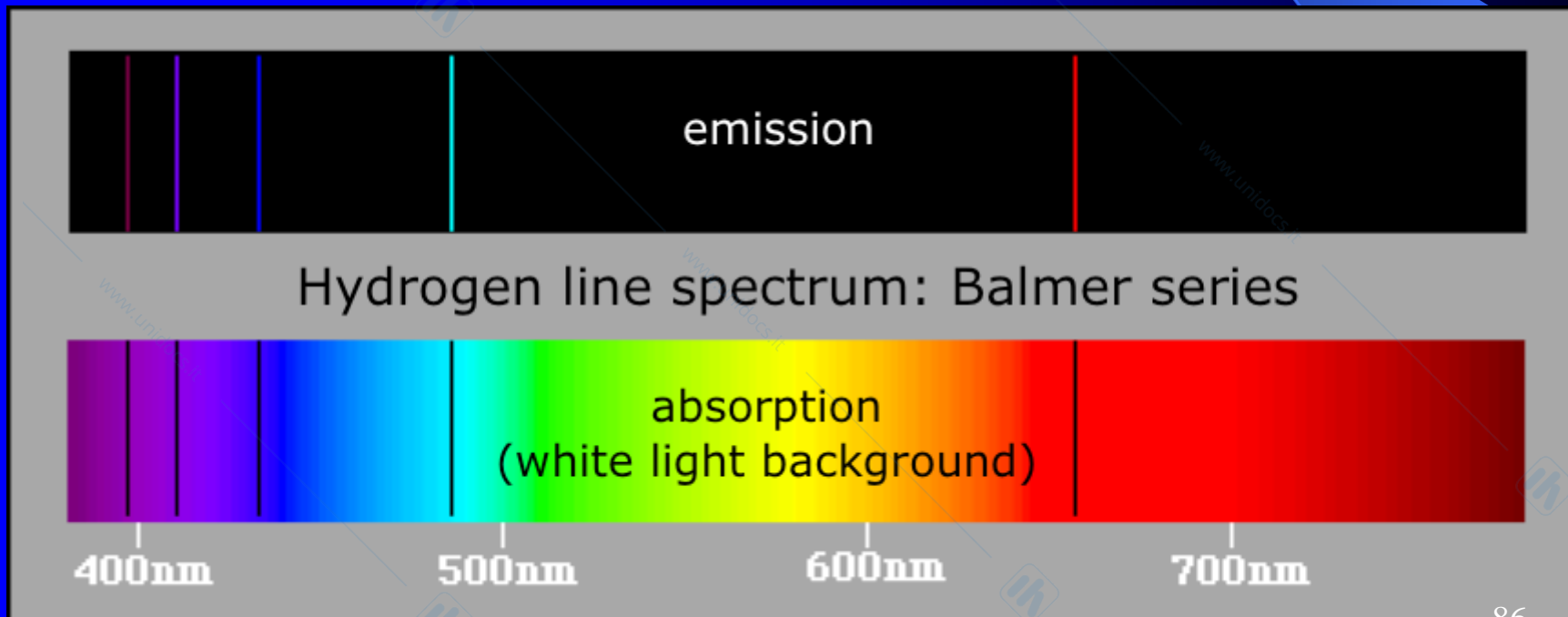
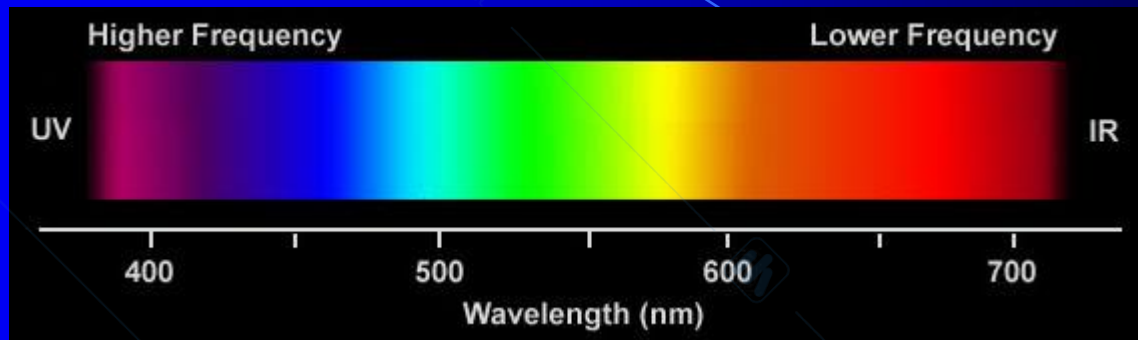

Line Spectra of Excited Atoms

- Excited atoms emit light of only certain wavelengths
- The wavelengths of emitted light depend on the element.

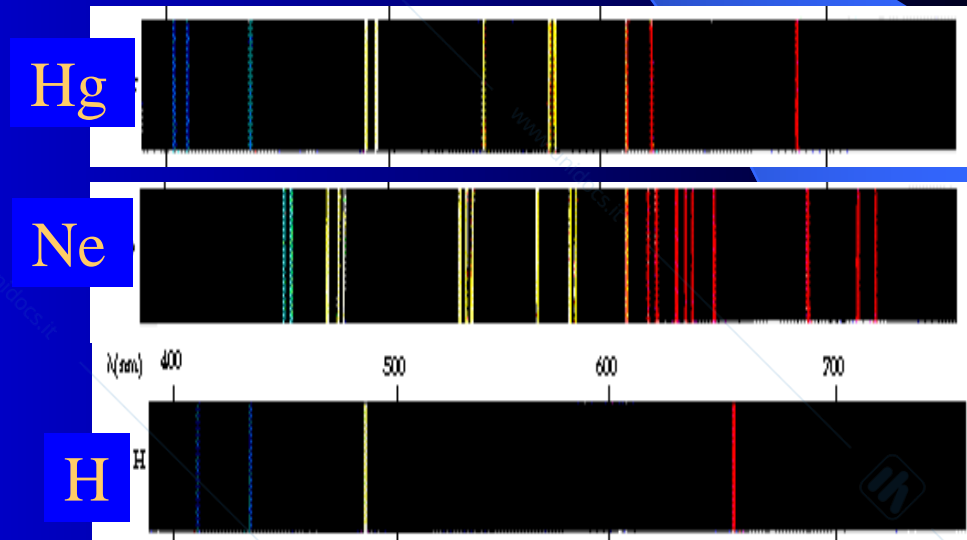

Emission spectrum of H

“Continuous” spectrum

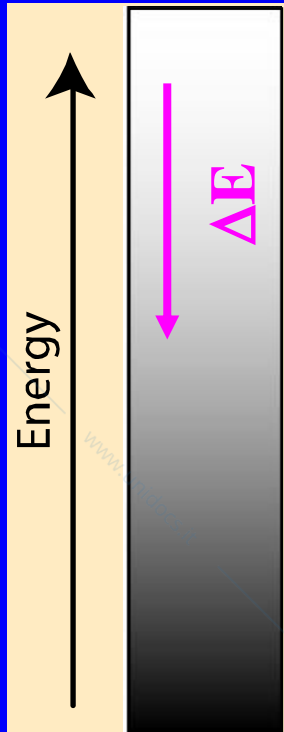

Any ΔE is possible

“Quantized” spectrum

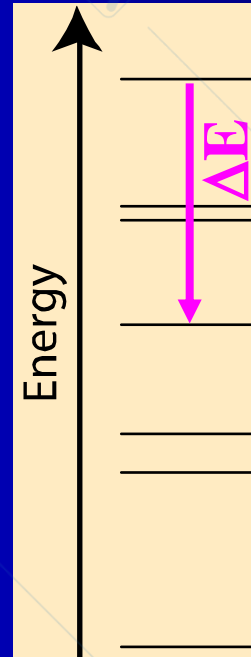

Only certain ΔE are allowed



Figura 1.6. (a) Modello dell'atomo di idrogeno secondo Bohr. (b) Energia rilasciata in maniera continua [1] o discreta (quantizzata) [2].

The energy levels are like the rungs of a ladder but are not equally spaced.

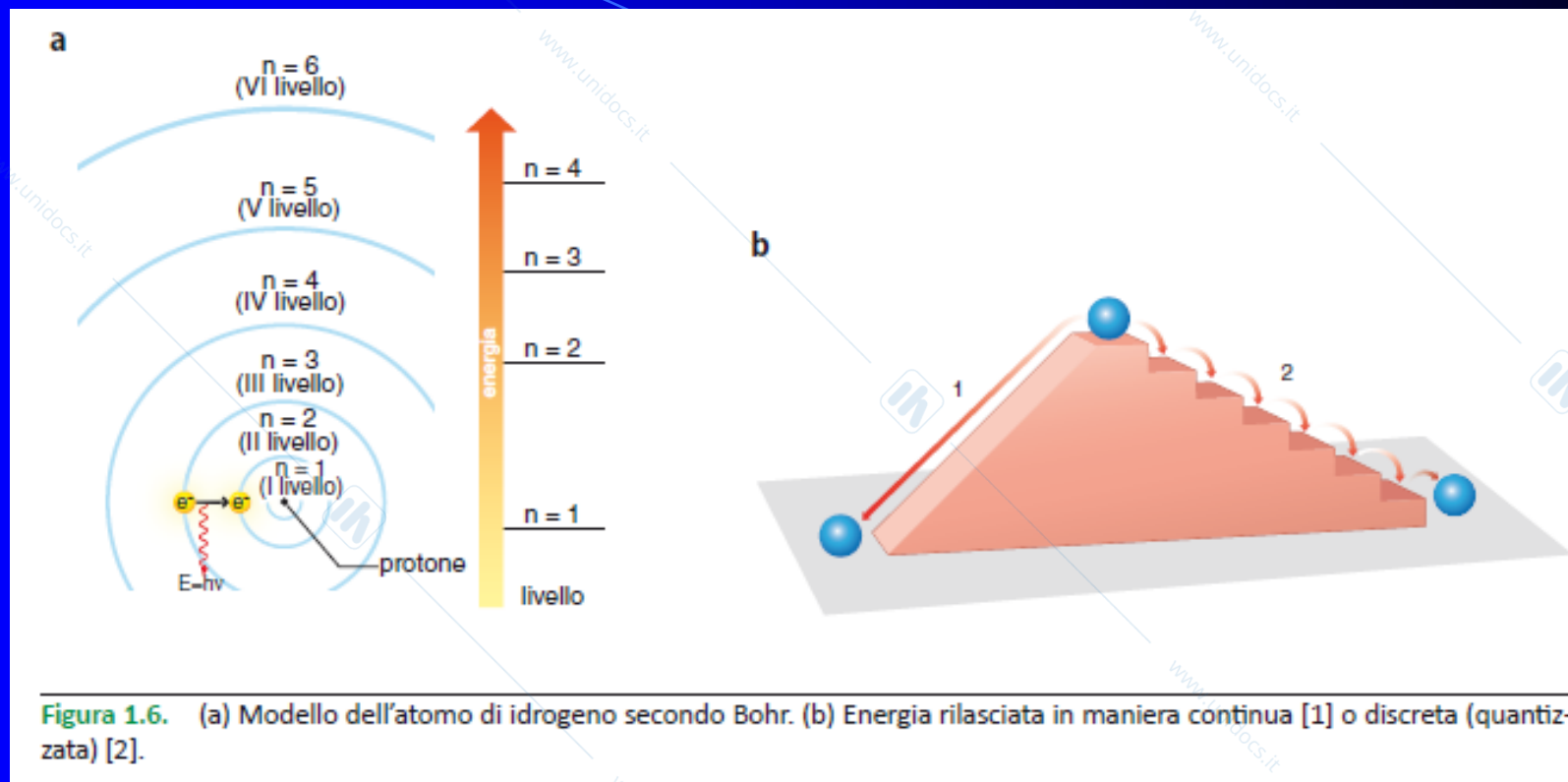
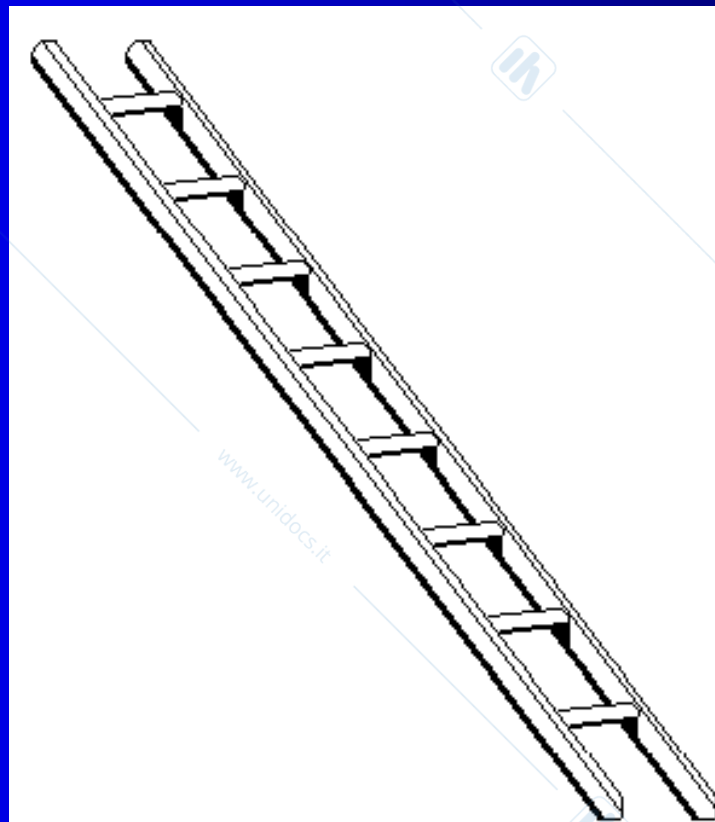

Quantum

- A quantum of energy is the amount of energy required to move an electron from one energy level to another.

- Energy emitted by the electron as it leaps from the higher to the lower energy level is proportional to the frequency of the light wave.
- Frequency define the color of visible light.

Bohr's Model & Planck's Constant

$$E = h\nu$$

frequency of radiation, sometimes written as f giving expression $E = hf$.

Quantum energy of a photon.

h = Planck's constant = 6.626×10^{-34} Joule·sec = 4.136×10^{-15} eV·s

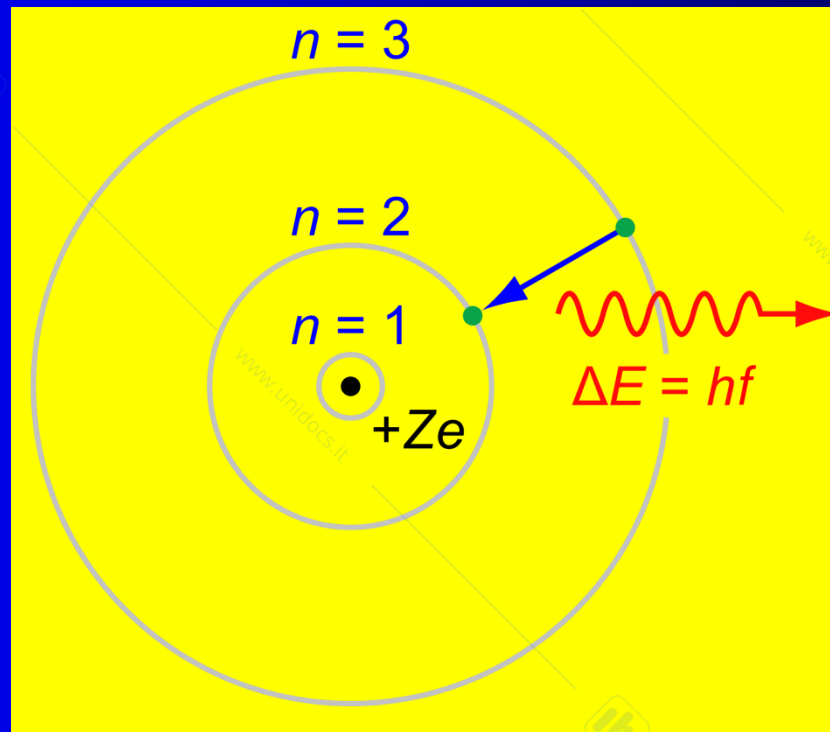



Figura 1.7. Emissione di energia radiante dell'atomo di idrogeno secondo il modello di Bohr.

Niels Bohr's Model (1913)

- Electrons orbit the nucleus in circular paths of fixed energy (energy levels).

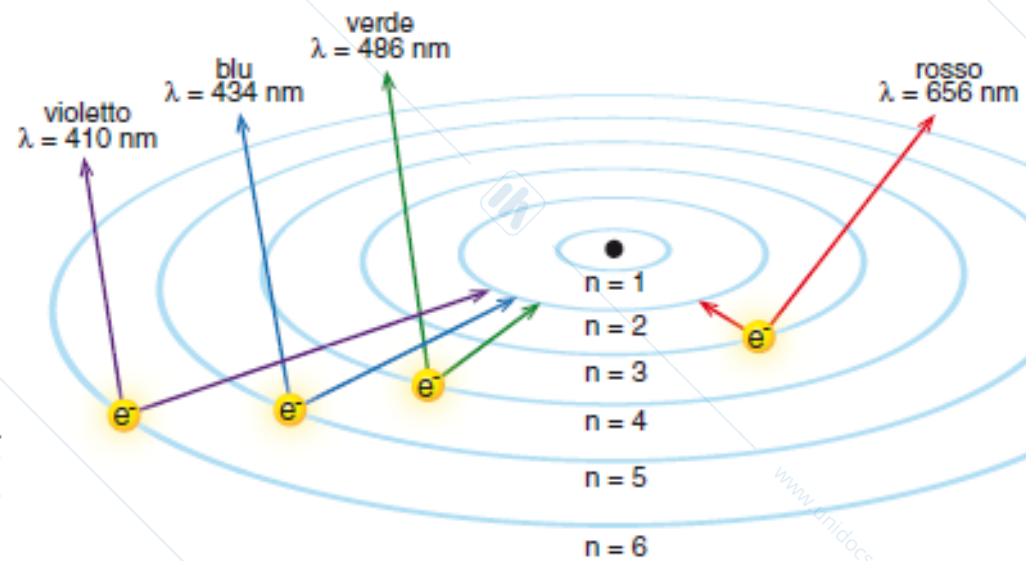
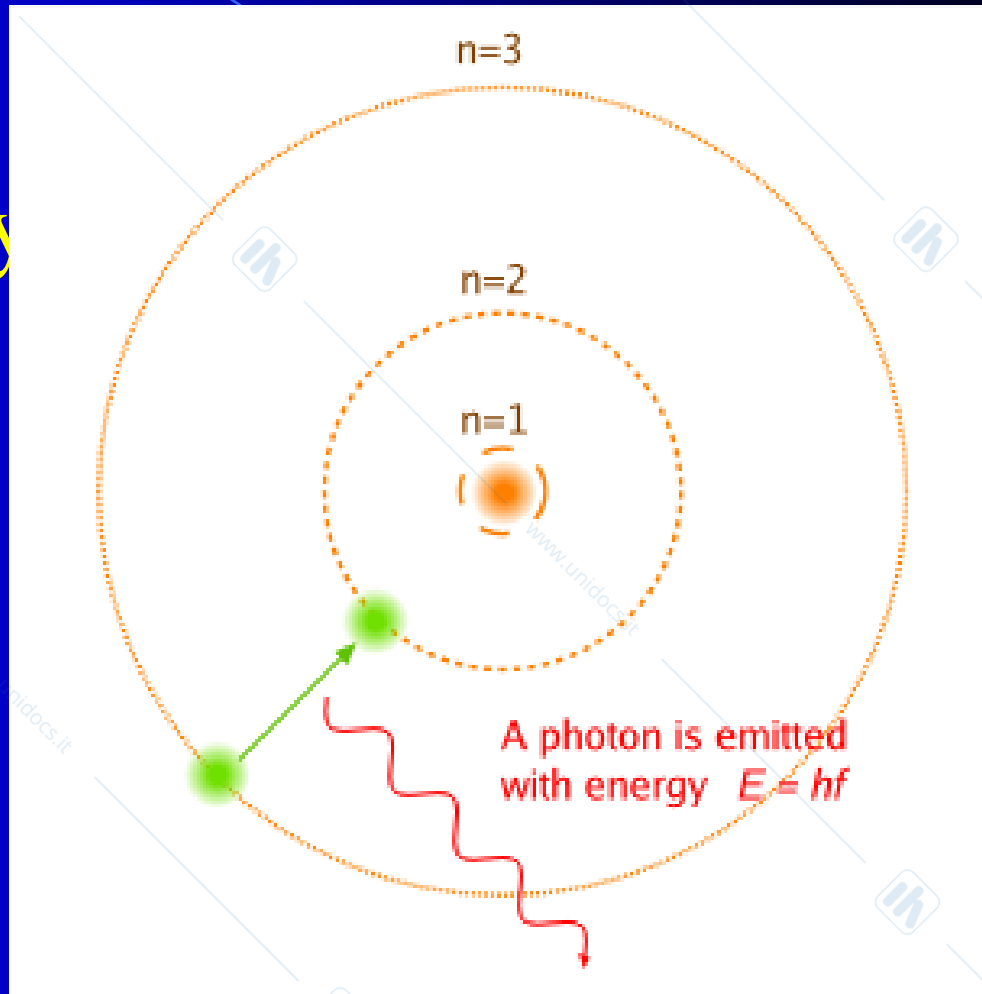

Niels Bohr's Atom

- Electrons can jump from energy level to energy level.
- Electrons absorb or emit light energy when they jump from one energy level to another.

Bohr Model

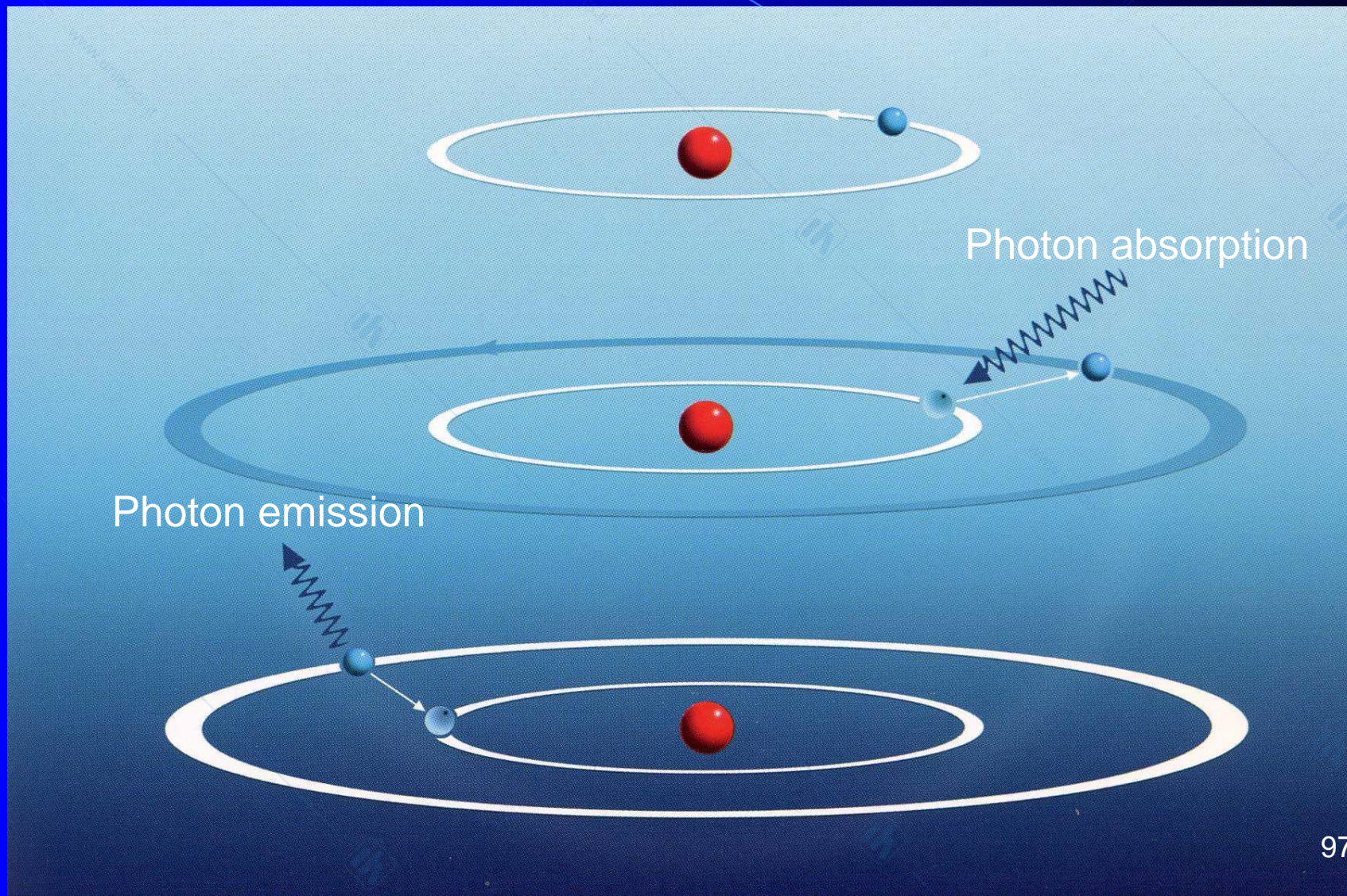

Bohr Model

In both cases, the photon energy is

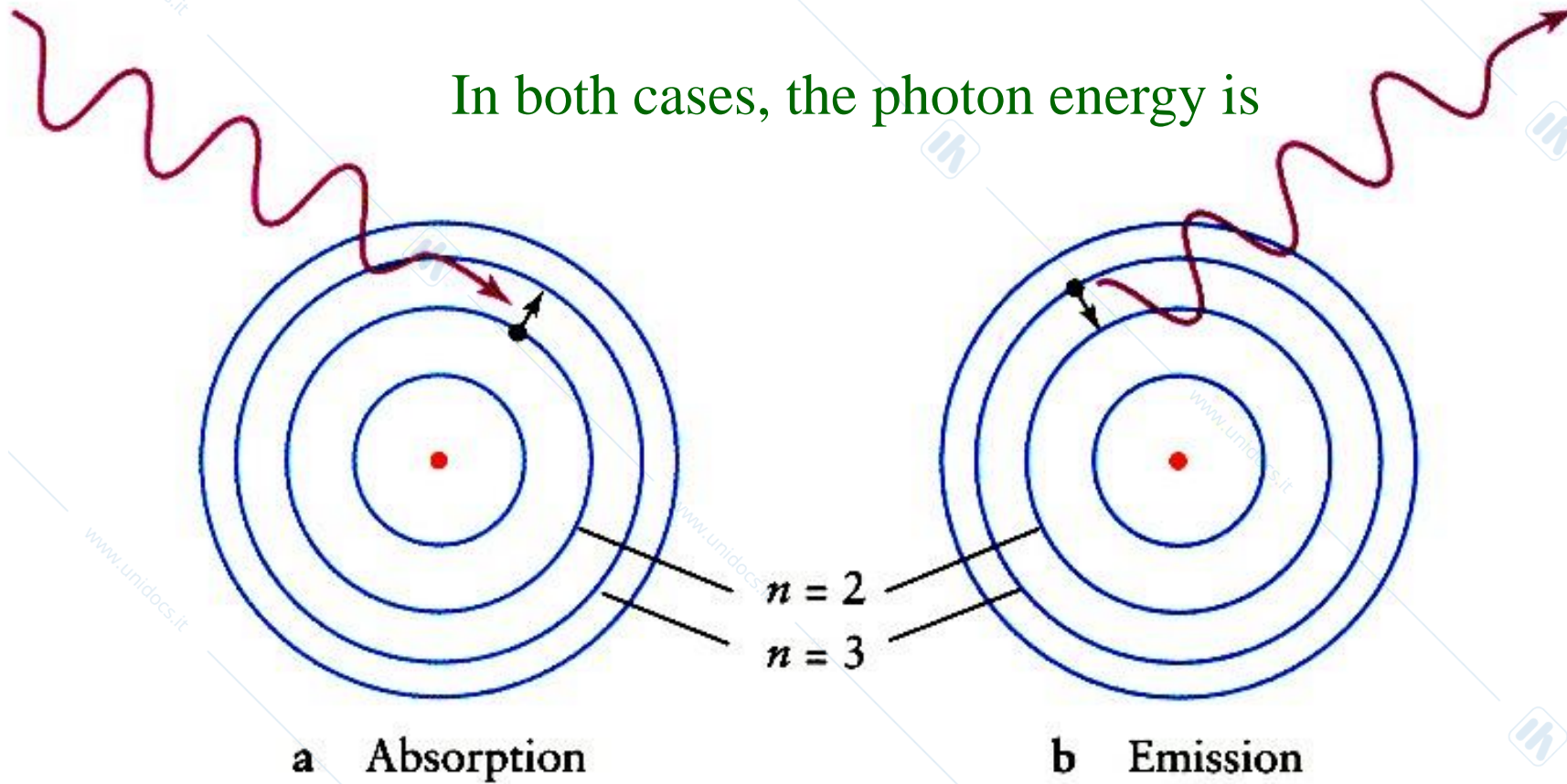

Emission spectrum of H

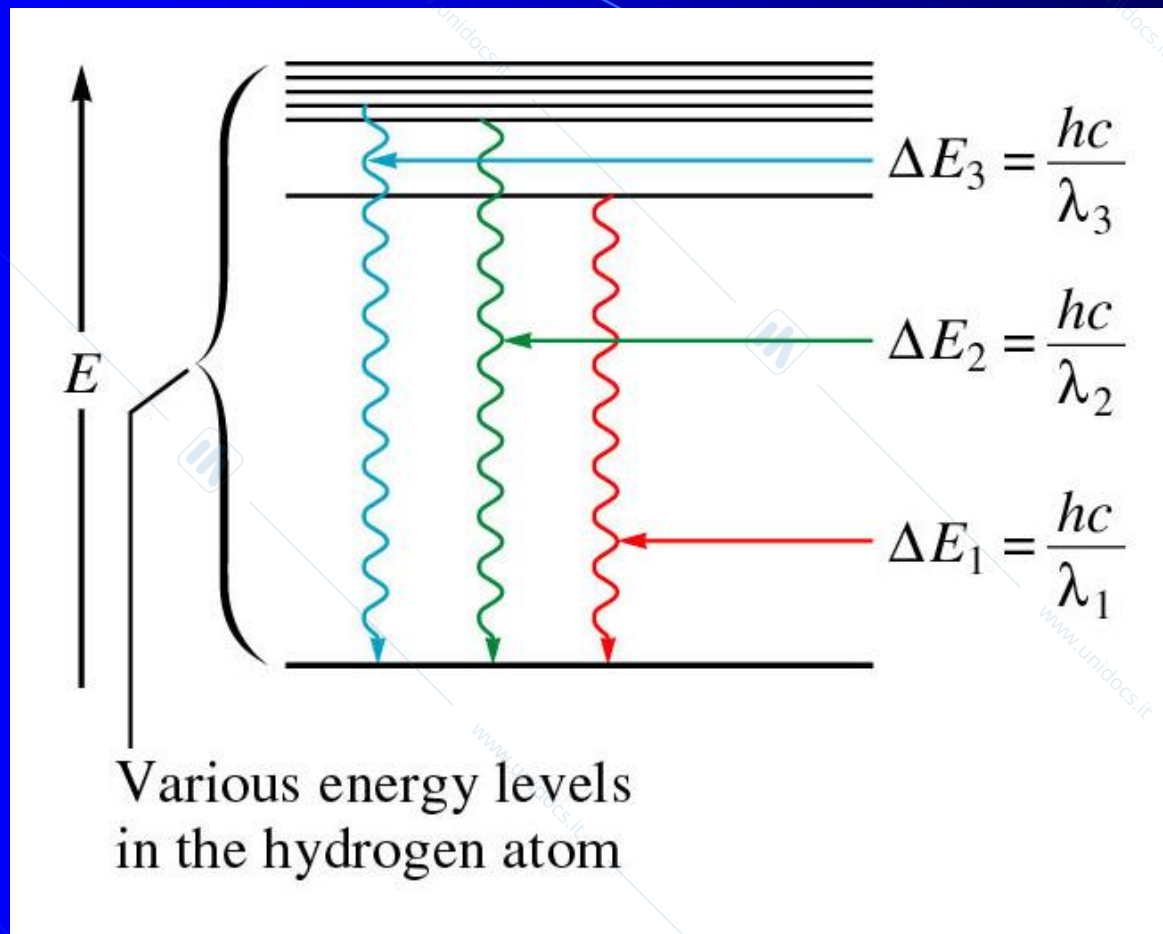

We can use the emission spectrum to determine the energy levels for the hydrogen atom.

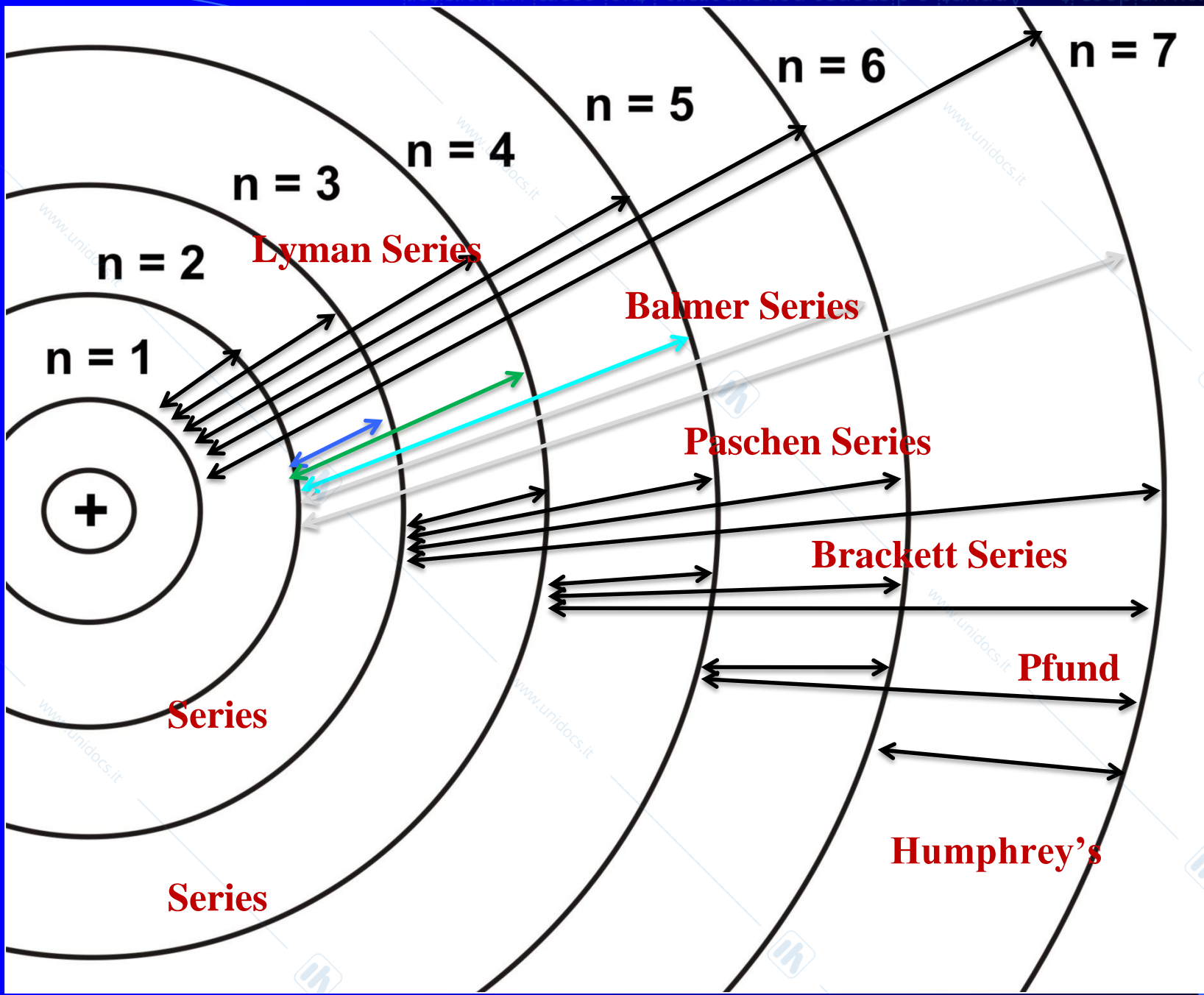

Bohr postulated that:

- Fixed energy related to the orbit
- Electrons cannot exist between orbits
- The higher the energy level, the further it is away from the nucleus
- An atom with maximum number of electrons in the outermost orbital energy level is stable (unreactive)

Excited State and Ground State

- Ground state: the lowest possible energy level an electron can be at.
- Excited state: an energy level higher than the ground state.

- The Bohr model explained the emission spectrum of the hydrogen atom but did not always explain those of other elements.

Bohr's Model

- Why don't the electrons fall into the nucleus?
- Move like planets around the sun.
- In circular stable orbits at different levels.
- Amounts of energy separate one level from another.

Quantum Mechanical Model

- 1920's
- Werner Heisenberg (Uncertainty Principle)
- Louis de Broglie (electron has wave properties)
- Erwin Schrodinger (mathematical equations using probability, quantum numbers)

Development of Atomic Models



Heisenberg : ‘More precisely the position of some particle is determined, the less precisely its momentum can be known!’



Broglie: ‘Moving particles have wave properties!’



Schrodinger: ‘There are orbitals!’

Quantum or Wave Mechanics



L. de Broglie
(1892-1987)

- Light has both wave & particle properties
- de Broglie (1924) proposed that all moving objects have wave properties.
- For light: $E = h\nu = hc / \lambda$
- For particles: $E = mc^2$ (Einstein)

Therefore,

$$mc = h / \lambda$$

and for particles

$$(\text{mass}) \times (\text{velocity}) = h / \lambda$$

λ for **particles** is called the de Broglie wavelength

Electron Motion Around Atom Shown as a de Broglie Wave

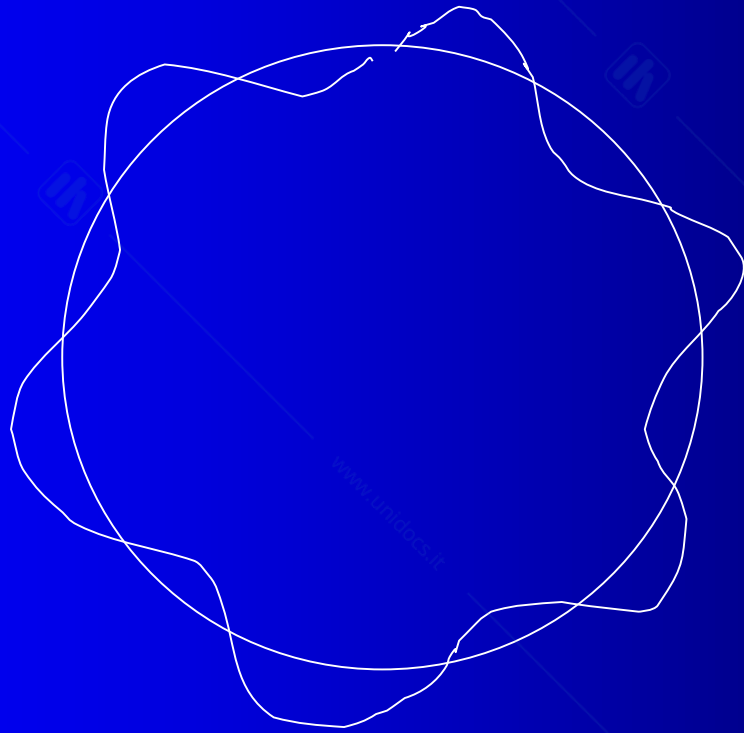

proprietà
alla pro-
nento al-
plica an-
cendo, la
non più

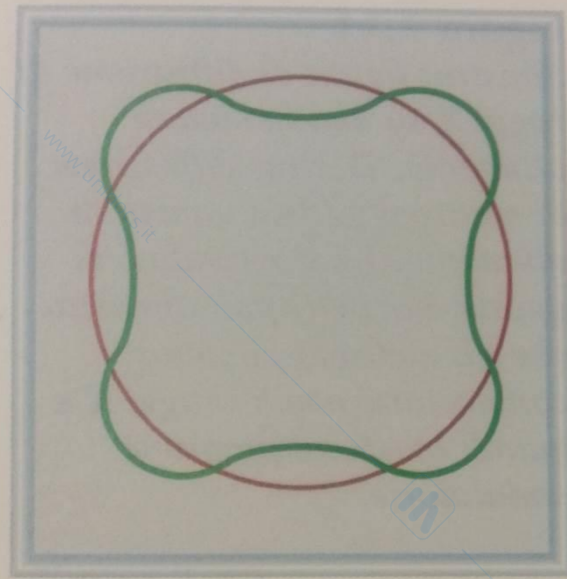

(a)

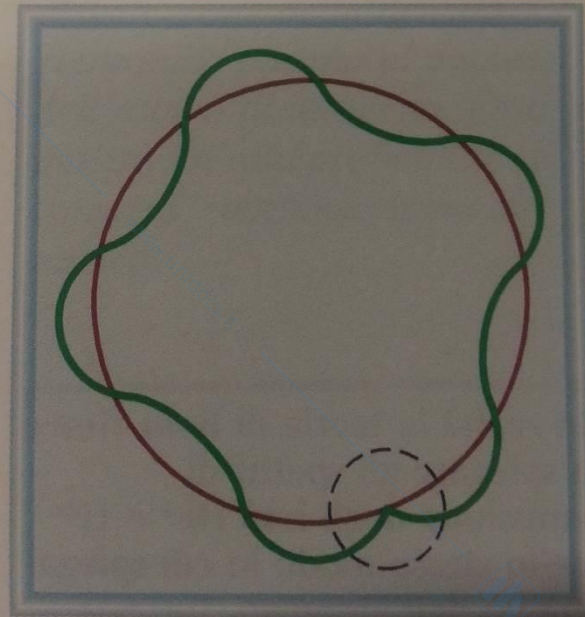

(b)

zio più
a palla
d'on-
e (b) e
(7.7).
devo-

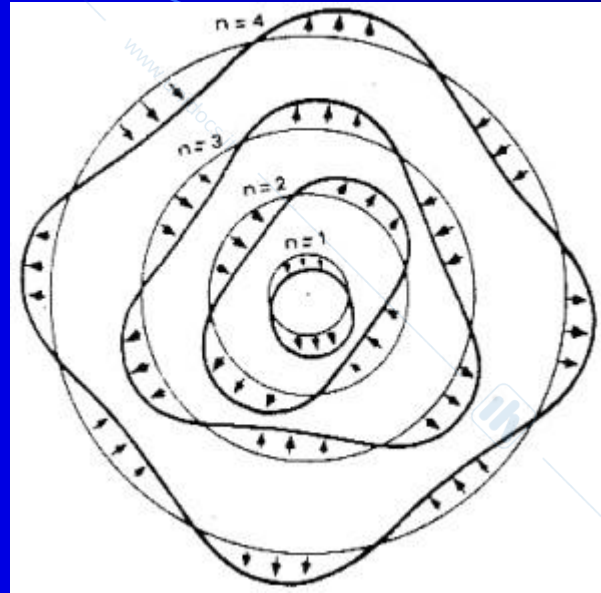

Il modello atomico di de Broglie non conservava più nulla della struttura planetaria originaria: esso ora assomigliava piuttosto ad una serie di corde concentriche vibranti (appunto le onde stazionarie) di diametro via via crescente a mano a mano che ci si allontanava dal nucleo.

Werner Heisenberg: Uncertainty Principle

- We can not know both the position and momentum of a particle at a given time.



Quantum Mechanical Model

- Electrons are located in specific energy levels.
- **Orbital:** A region in space in which there is high probability of finding an electron.
- There is no exact path around the nucleus.
- The model estimates the **probability** of finding an electron in a certain position.

Quantum or Wave Mechanics

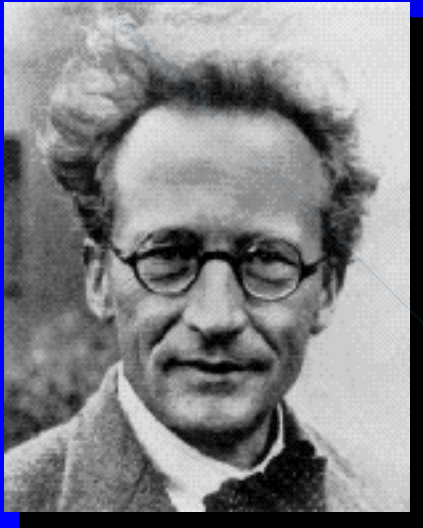

E. Schrodinger
1887-1961

Schrodinger applied idea of e- behaving as a wave to the problem of electrons in atoms.

Solution to **WAVE EQUATION** gives set of mathematical expressions called **WAVE FUNCTIONS, Ψ**

Each describes an allowed energy state of an e-

Quantization introduced naturally.

Erwin Schrodinger, 1925

Quantum (wave) Mechanical Model of the Atom

- Four quantum numbers are required to describe the state of the hydrogen atom.
- **Erwin Schrödinger:** Replace the precise trajectory of particles by a wavefunction (ψ), a mathematical function that varies with position



Bohr to Heisenberg

Bohr's Model

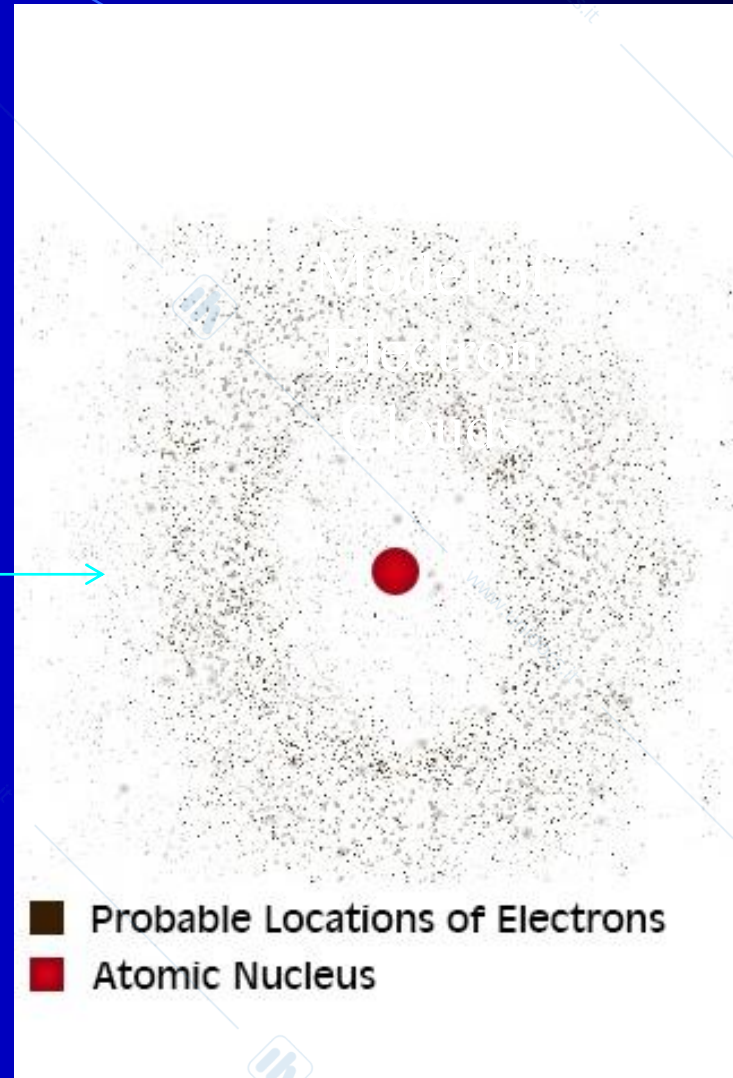
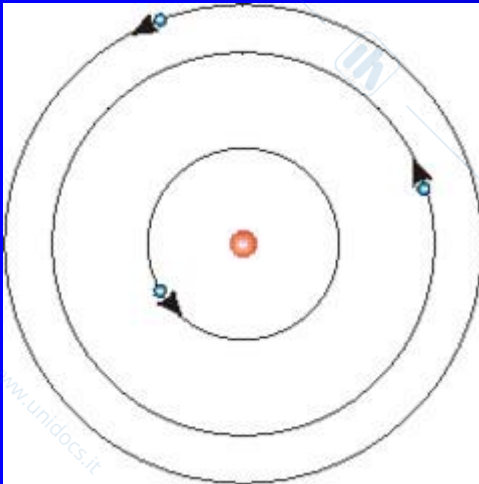

Bohr to Heisenberg

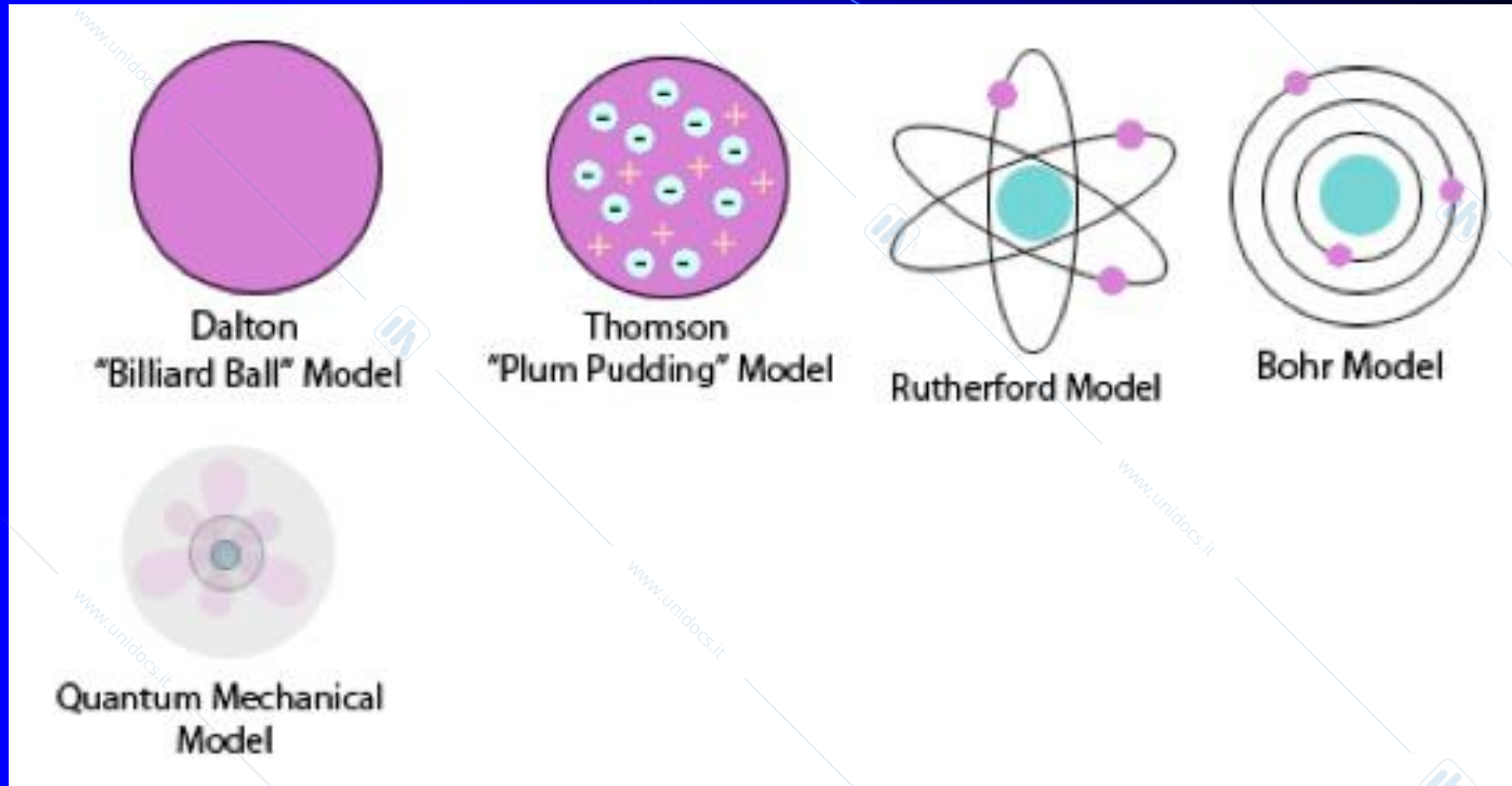

Comparing Orbit and Orbital

ORBIT

It is well-defined circular path followed by electron around nucleus.

It represents two dimensional motion of electron around nucleus.

The maximum no. of electrons in an orbit is $2n^2$.

Orbit is circular in shape.

ORBITAL

It is a region of space around the nucleus where the probability of finding an electron is maximum.

It represents three dimensional motion of electron around nucleus.

The maximum no. of electrons in an orbital is 2.

Orbitals have different shapes.

WAVE FUNCTIONS, Ψ

- Ψ is a function of distance and two angles.
- For 1 electron, Ψ corresponds to an **ORBITAL** — the region of space within which an electron is found.
- Ψ does NOT describe the exact location of the electron.
- Ψ^2 is proportional to the probability of finding an e⁻ at a given point.

BASIC CONCEPTS OF QUANTUM MECHANICS

- ELECTRONS EXIST IN AREAS OUTSIDE THE NUCLEUS. THESE AREAS ARE CALLED ENERGY LEVELS. YOU MIGHT HAVE HEARD OF THEM BEFORE AS “SHELLS”. THERE ARE NUMEROUS ENERGY LEVELS AT WHICH THE ELECTRON CAN BE FOUND, EACH AT A PROGRESSIVE HIGHER ENERGY.
- THESE LEVELS ARE ASSIGNED NUMBERS 1,2,3, ETC. AS THE NUMBER INCREASES, THE ENERGY STATE OF THE ELECTRON BECOMES HIGHER.

Quantum Numbers:

specify the properties of atomic orbitals and their electrons.

Quantum Numbers

- According to Heisenberg's Uncertainty Principle, it is not possible to give the exact position of an electron and its energy at the same time.
- But the probability of finding an electron in an orbital of given energy can be determined.

Four Quantum Numbers

1. Principal Quantum Number
2. Orbital Quantum Number
3. Magnetic Quantum Number
4. Spin Quantum Number

Quantum Mechanics and Atomic Orbitals

Orbitals and Quantum Numbers

- Schrödinger's equation requires 3 quantum numbers:
 1. **Principal Quantum Number, n .** This is the same as Bohr's n . As n becomes larger, the atom becomes larger and the electron is further from the nucleus. ($n = 1, 2, 3, 4, \dots$)
 2. **Angular Momentum Quantum Number, l .** This quantum number depends on the value of n . The values of l begin at 0 and increase to $(n - 1)$. We usually use letters for l (s, p, d and f for $l = 0, 1, 2,$ and 3). Usually we refer to the s, p, d and f -orbitals.
 3. **Magnetic Quantum Number, m_l .** This quantum number depends on l . The magnetic quantum number has integral values between $-l$ and $+l$. Magnetic quantum numbers give the 3D orientation of each orbital.

Quantum Numbers of Wavefunctions

Quantum #	Symbol	Values	Description
Principal	n	1,2,3,4,...	Size & Energy of orbital
Angular Momentum	l	0,1,2,...($n-1$) for each n	Shape of orbital
Magnetic	m	$-l, \dots, 0, \dots, +l$ for each l	Relative orientation of orbitals within same l
Spin	M_s or s	$+1/2$ or $-1/2$	Spin up or Spin down

Angular Momentum Quantum # (l)	Name of Orbital
0	s (sharp)
1	p (principal)
2	d (diffuse)
3	f (fundamental)
4	g

Principal Quantum Number

- Main energy level of an orbital
- An increase in n also means increase in the energy of the electron in the orbital.
- $n = 1, 2, 3, \dots$
- Maximum no. of electrons = $2n^2$
- Each main energy level has sub-levels

Azimuthal Quantum Number

- Also called Angular Momentum Number
- Defines the shape of the orbital
- Values range from 0 to $n-1$

Orbital Quantum Number, ℓ

(Angular Momentum Quantum Number)

- Indicates shape of orbital sublevels

- $\ell = n-1$

<u>ℓ</u>	<u>sublevel</u>
0	s
1	p
2	d
3	f
4	g

Azimuthal Quantum Number

1	Sublevel	Orbital Shape
0	s(harp)	Spherical
1	p(rincipal)	dumbbell-shaped
2	d(iffused)	Cloverleaf
3	f(undamental)	Too complex

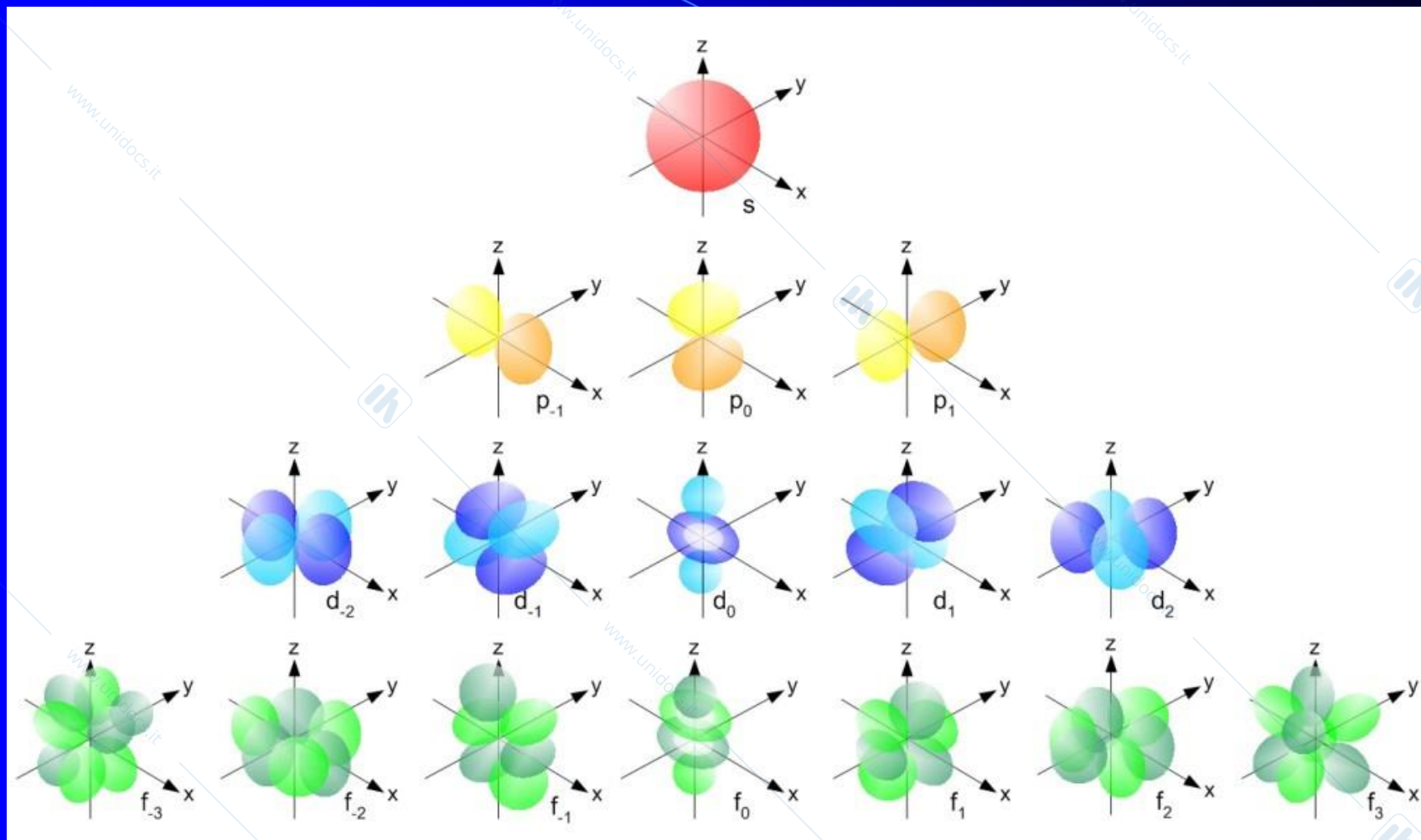

Magnetic Quantum Number, m_l

- Indicates the orientation of the orbital in space.
- Values of m_l : integers $-l$ to $+l$
- Values per sublevel = $2l + 1$
- The number of values represents the number of orbitals.
- Example:
for $l = 2$, $m_l = -2, -1, 0, +1, +2$

Which sublevel does this represent?

Answer: d

Magnetic Quantum Number, m

Sublevel Type	l	m_l
s	0	0
p	1	-1, 0, +1
d	2	-2, -1, 0, 1, 2

Spin Quantum Number, s

- Spin of the electron
 - Values are $+1/2$ and $-1/2$
 - Clockwise and Counterclockwise
- Opposite spins because of Pauli Exclusion Principle

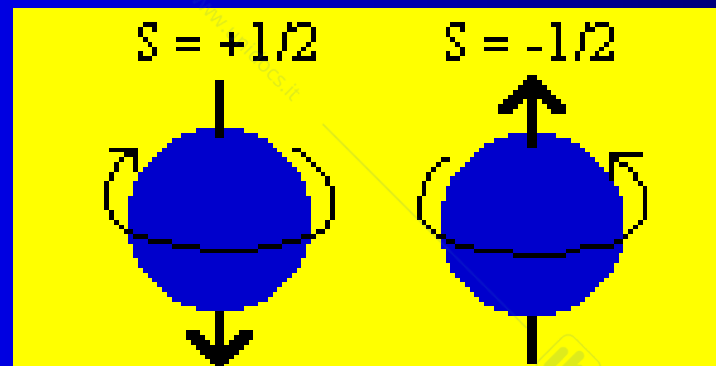

Many-Electron Atoms

Electron Spin and the Pauli Exclusion Principle

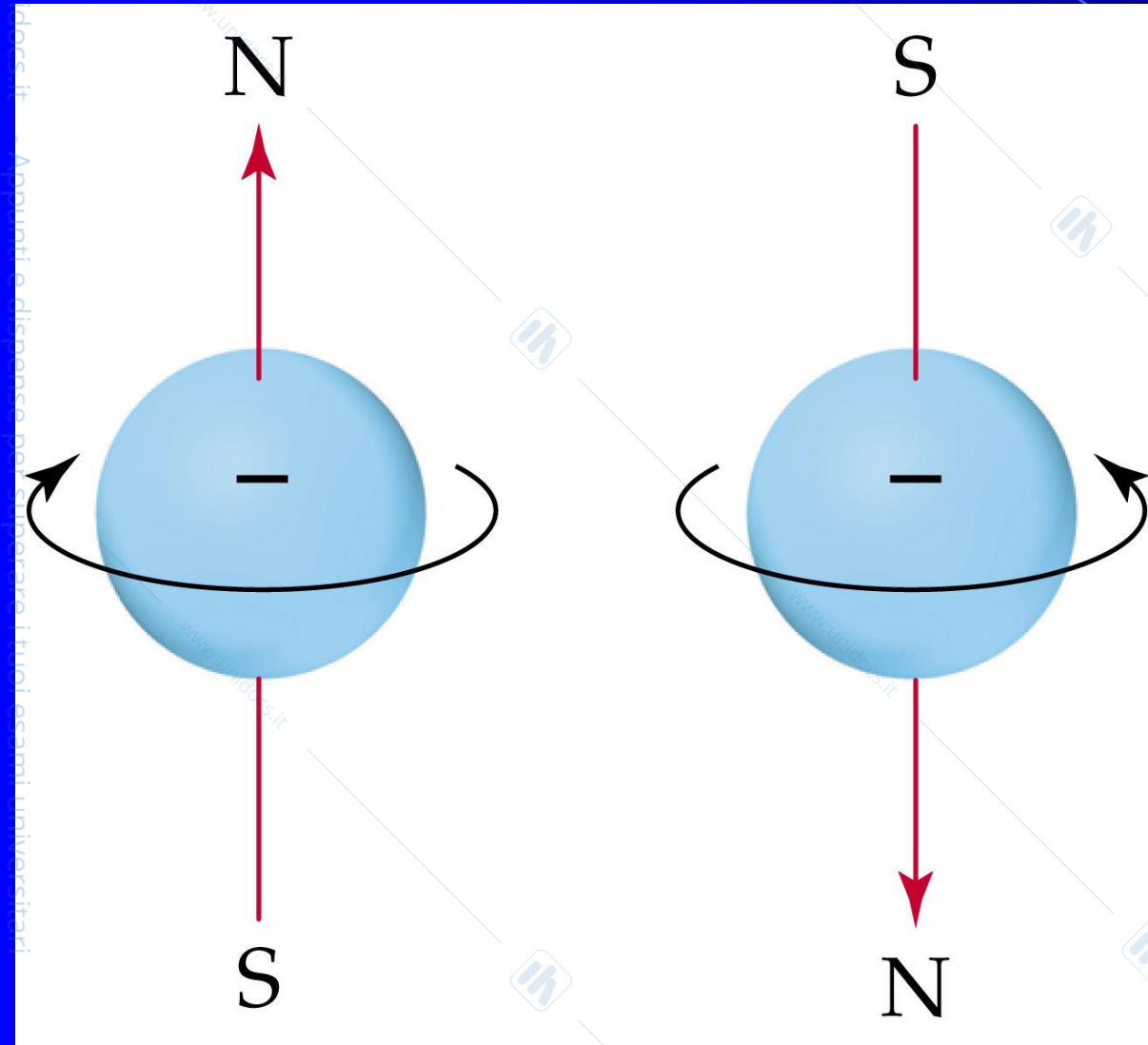

Many-Electron Atoms

Electron Spin and the Pauli Exclusion Principle

- Since electron spin is quantized, we define $m_s = \text{spin quantum number} = \pm \frac{1}{2}$.
- **Pauli's Exclusions Principle:** no two electrons can have the same set of 4 quantum numbers.
 - Therefore, two electrons in the same orbital must have opposite spins.

Assigning Quantum Numbers

**Quantum numbers may be view as an electrons address.
Just like your address, each has its own distinct set of values.**

For example in order to receive a letter, the address must contain state and zip, city, street and name. No other person has the exact same set of information. It is similar for electrons. They each have their own address, n, l, m, and s.

NO TWO ELECTRON IN AN ATOM CAN HAVE THE EXACT SAME SET OF QUANTUM NUMBERS.

QUANTUM NUMBERS ARE ASSIGNED TO EACH EACH ELECTRON USING THE RULES PREVIOUSLY STATED, STARTING FROM THE LOWEST VALUES.

Pauli Exclusion Principle

Electron Spin and the Pauli Exclusion Principle

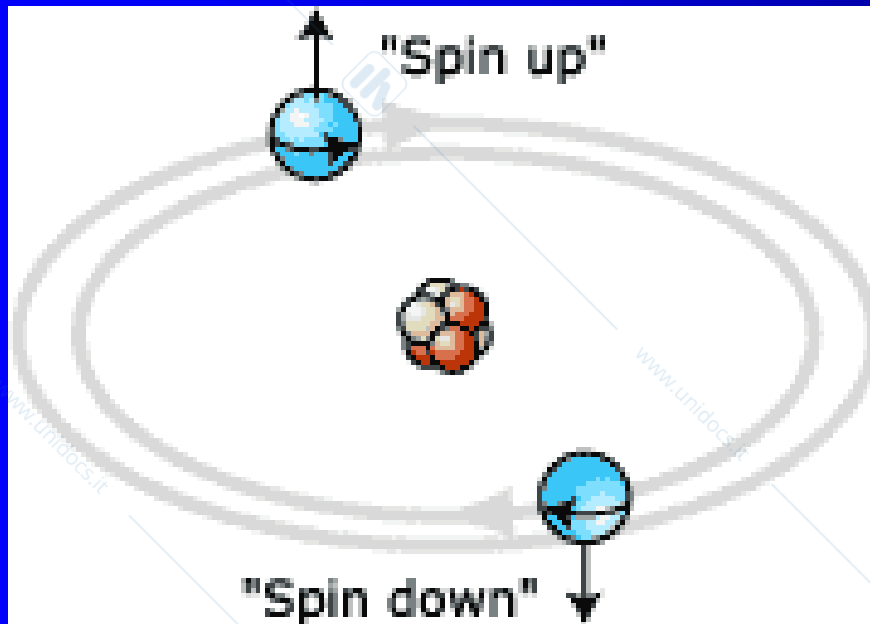

Pauli Exclusion Principle

Electron Spin and the Pauli Exclusion Principle

- Since electron spin is quantized, we define $m_s = \text{spin quantum number} = \pm \frac{1}{2}$.
- **Pauli's Exclusions Principle:** no two electrons can have the same set of 4 quantum numbers.
 - Therefore, two electrons in the same orbital must have opposite spins.

Quantum Number Summary

$$n = 1$$

$$l = 0$$

$$m = 0$$

$$s = +\frac{1}{2} \text{ or } -\frac{1}{2}$$

$$n = 2$$

$$l = 0$$
$$l = 1$$

$$m = -1$$
$$m = 0$$
$$m = +1$$

$$s = +\frac{1}{2} \text{ or } -\frac{1}{2}$$

$$n = 3$$

$$l = 0$$
$$l = 1$$
$$l = 2$$

$$m = -2$$
$$m = -1$$
$$m = 0$$
$$m = +1$$
$$m = +2$$

$$s = +\frac{1}{2} \text{ or } -\frac{1}{2}$$

$$n = 4$$

$$l = 0$$
$$l = 1$$
$$l = 2$$
$$l = 3$$

$$m = -3$$
$$m = -2$$
$$m = -1$$
$$m = 0$$
$$m = +1$$
$$m = +2$$
$$m = +3$$

$$s = +\frac{1}{2} \text{ or } -\frac{1}{2}$$

Table 8.1 • Number of Electrons Accommodated in Electron Shells and Subshells With $n = 1$ to 6

Electron Shell (n)	Subshells Available	Orbitals Available ($2\ell + 1$)	Number of Electrons Possible in Subshell [$2(2\ell + 1)$]	Maximum Electrons Possible for n th Shell ($2n^2$)
1	<i>s</i>	1	2	2
2	<i>s</i>	1	2	8
	<i>p</i>	3	6	
3	<i>s</i>	1	2	18
	<i>p</i>	3	6	
	<i>d</i>	5	10	
4	<i>s</i>	1	2	32
	<i>p</i>	3	6	
	<i>d</i>	5	10	
	<i>f</i>	7	14	
5	<i>s</i>	1	2	50
	<i>p</i>	3	6	
	<i>d</i>	5	10	
	<i>f</i>	7	14	
	<i>g</i> *	9	18	
6	<i>s</i>	1	2	72
	<i>p</i>	3	6	
	<i>d</i>	5	10	
	<i>f</i> *	7	14	
	<i>g</i> *	9	18	
	<i>h</i> *	11	22	

*These orbitals are not used in the ground state of any known element.

Quantum Mechanics and Atomic Orbitals

Orbitals and Quantum Numbers

TABLE 6.2 Relationship Among Values of n , l , and m_l Through $n = 4$

n	Possible Values of l	Subshell Designation	Possible Values of m_l	Number of Orbitals in Subshell	Total Number of Orbitals in Shell
1	0	1s	0	1	1
2	0	2s	0	1	4
	1	2p	1, 0, -1	3	
3	0	3s	0	1	9
	1	3p	1, 0, -1	3	
	2	3d	2, 1, 0, -1, -2	5	
4	0	4s	0	1	16
	1	4p	1, 0, -1	3	
	2	4d	2, 1, 0, -1, -2	5	
	3	4f	3, 2, 1, 0, -1, -2, -3	7	

Orbital types defined by the azimuthal quantum number

$l = 0$
s type orbital

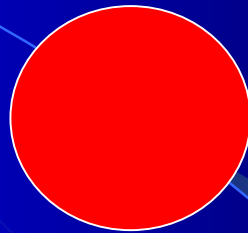

One orientation

$l = 1$
p type orbital

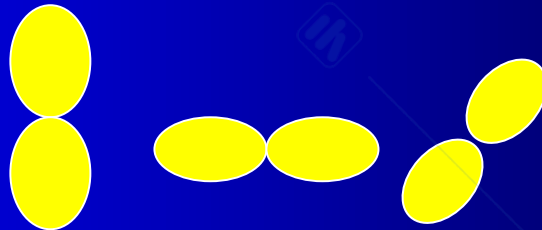

Three orientations

$l = 2$
d type orbital

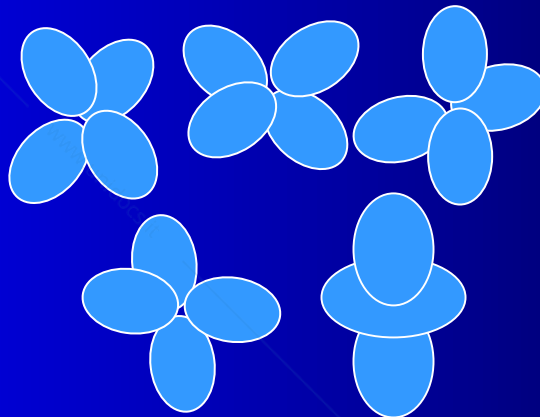

Five orientations

$l = 3$
f type orbital

Seven orientations (not shown)

s Orbitals

All s orbitals are spherical in shape.

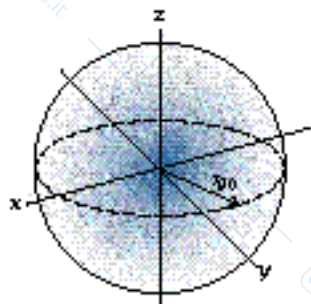

(a) Dot pattern of an electron with a 1s atomic orbital. Each dot represents the position of the electron at a different instant in time.

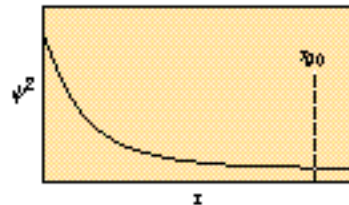

(b) A plot of the probability density as a function of distance for a one-electron atom with a 1s electron.

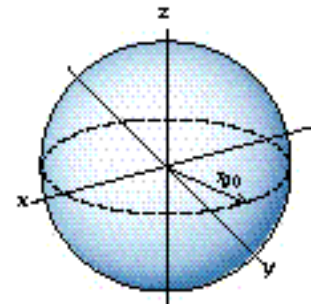

(c) The surface of the sphere within which the electron is found 90% of the time for a 1s orbital.

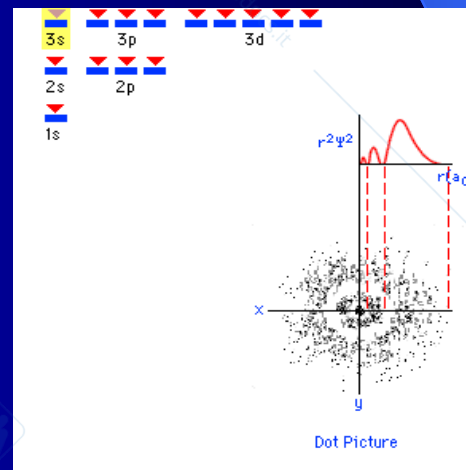
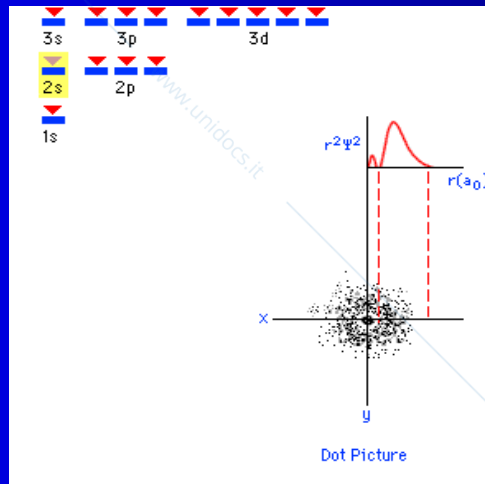
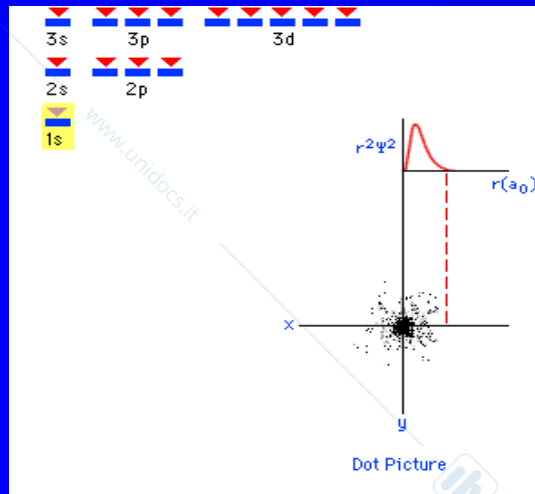

Atomic Orbital s

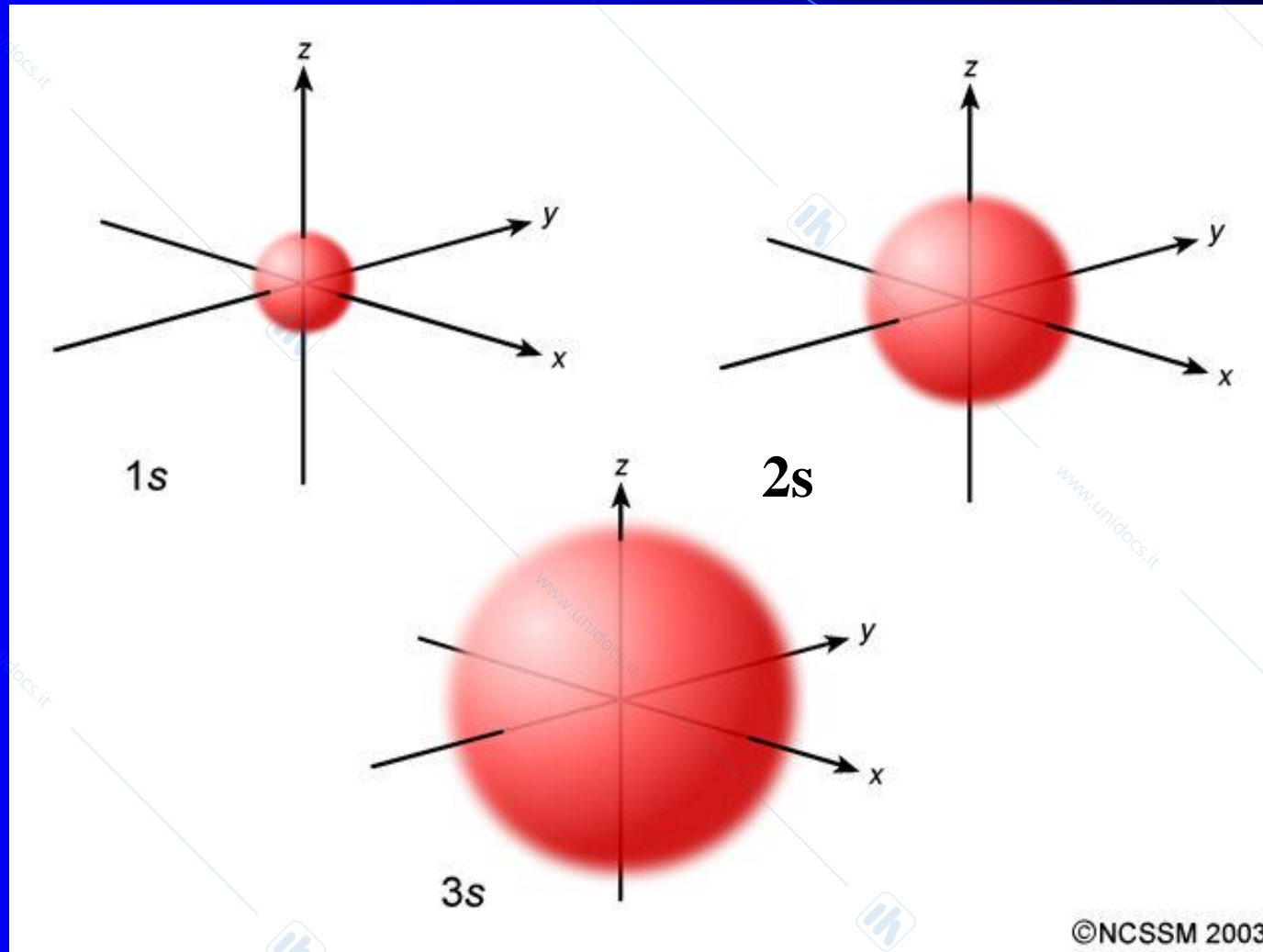

s Orbitals

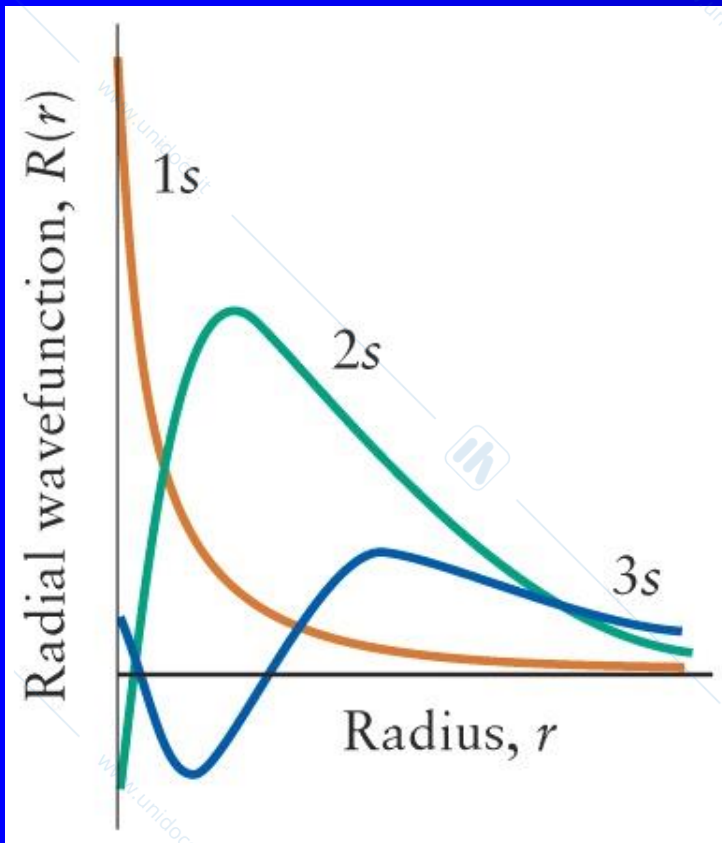

Wavefunctions of s orbitals of higher energy have more complicated radial variation with nodes.

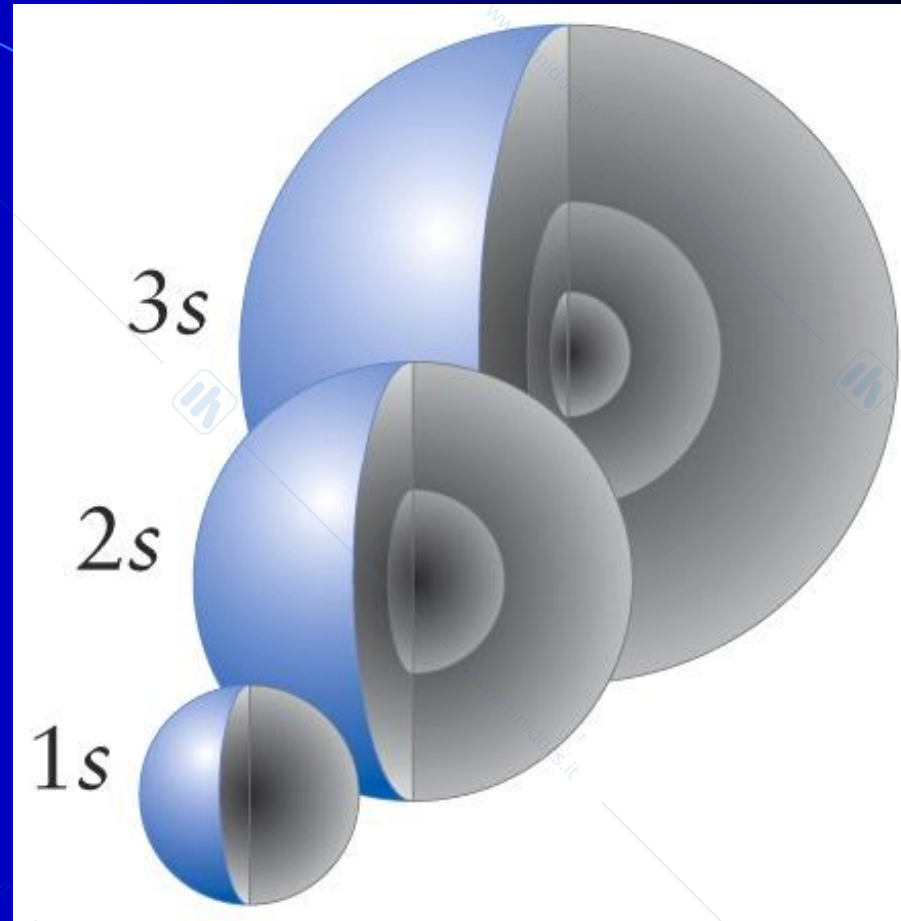

Boundary surface encloses surface with a $> 90\%$ probability of finding electron

p Orbitals

For $l = 1$ $m_l = -1, 0, +1$
this is a **p** subshell
with **3** orbitals

Typical p orbital

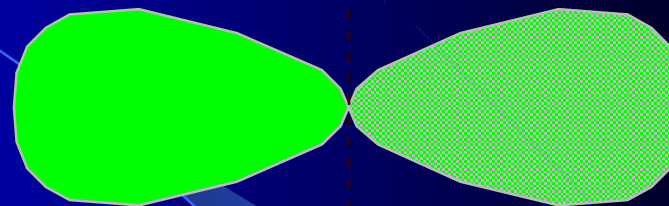

planar node

When $l = 1$, there is a
PLANAR NODE through
the nucleus.

Representations of Orbitals

The p-Orbitals

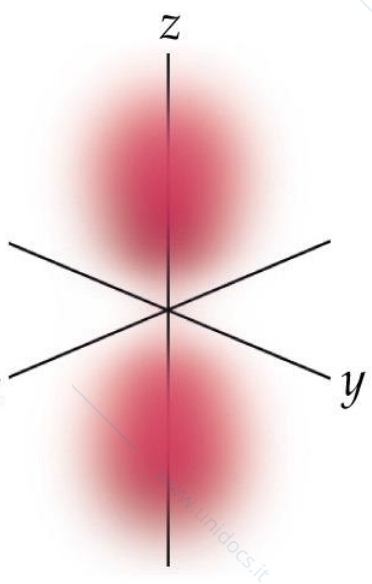

(a)

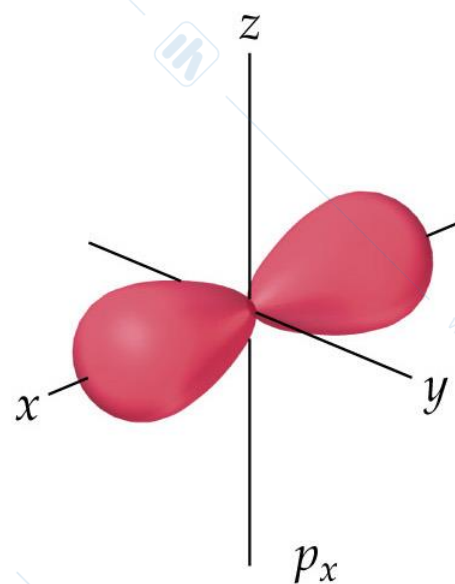
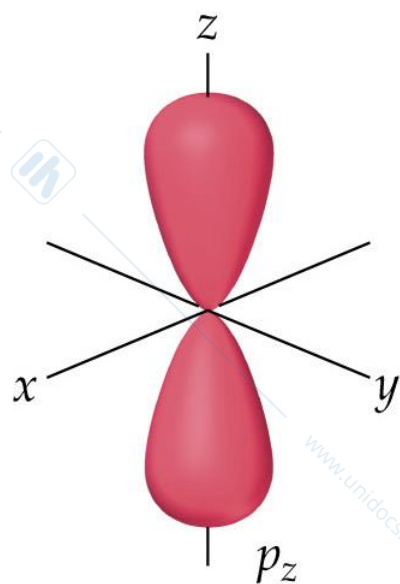

(b)

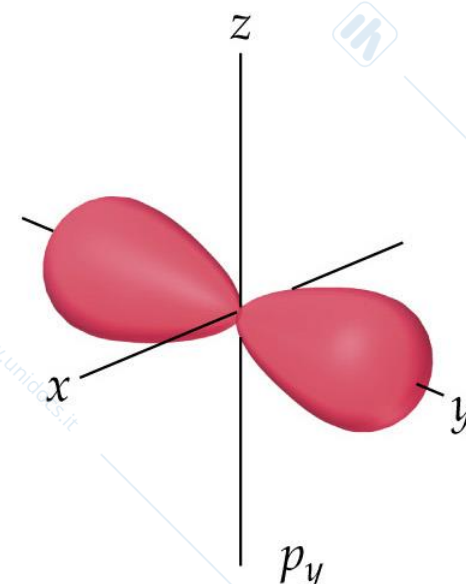

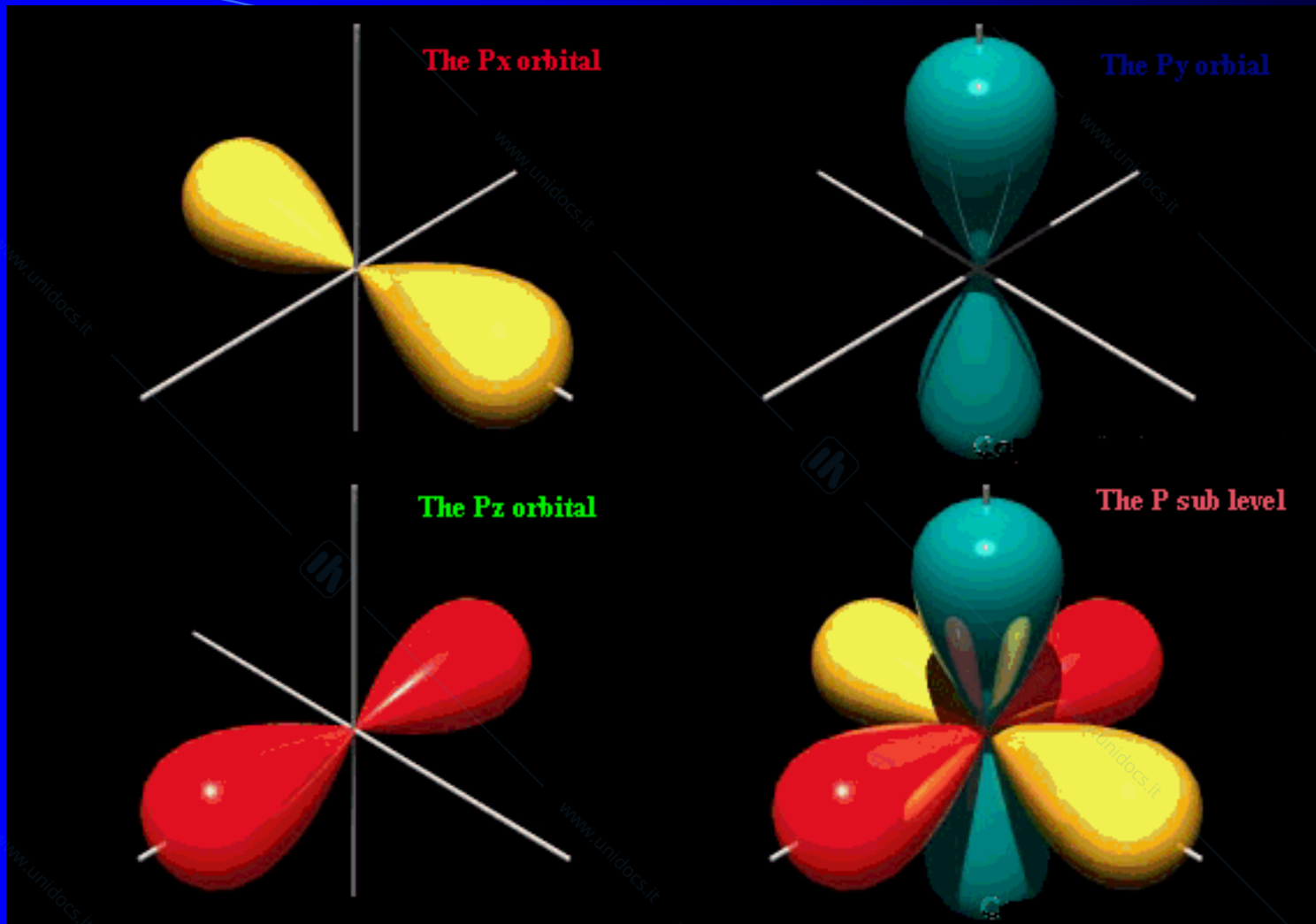

p orbitals:

3 p orbitals $l = 1$,
 $m = +1, 0, -1$

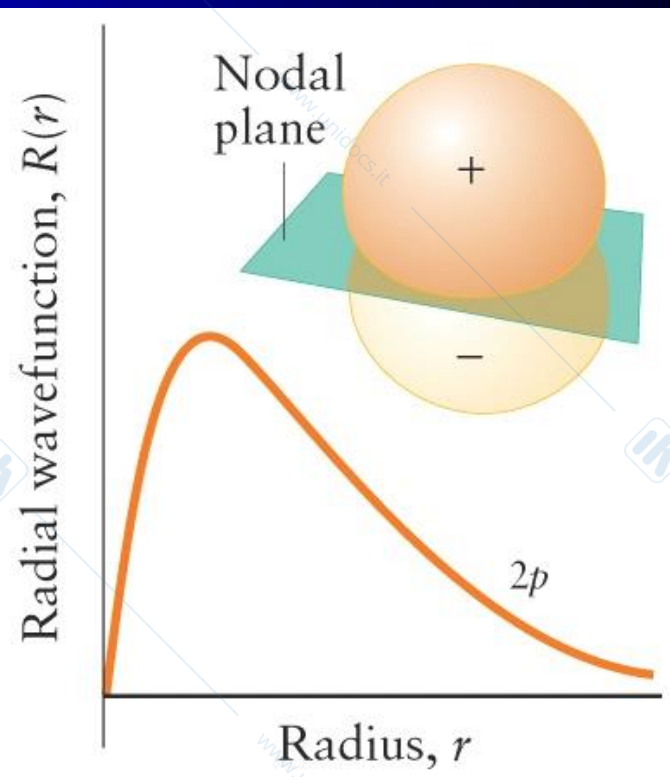

Nodal plane

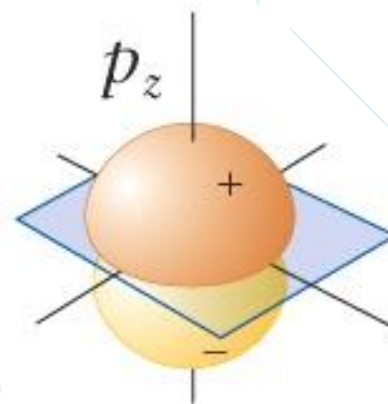
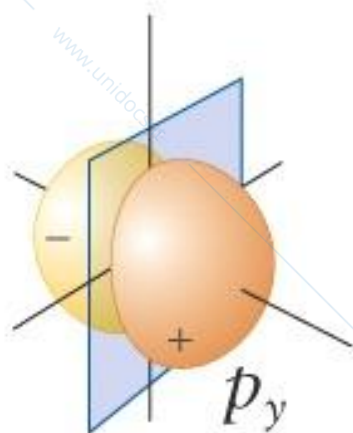
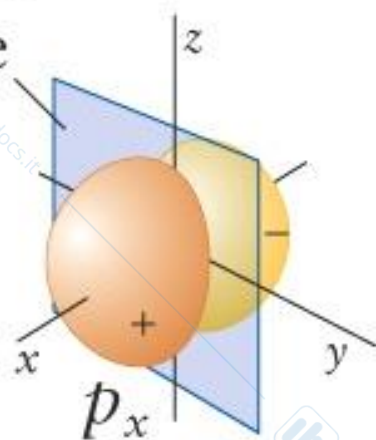

d Orbitals

For $l = 2$, $m_l = -2, -1, 0, +1, +2$
→ d subshell with 5 orbitals

d orbitals: Five d orbitals $l = 2$, $m = +2, +1, 0 - 1, -2$

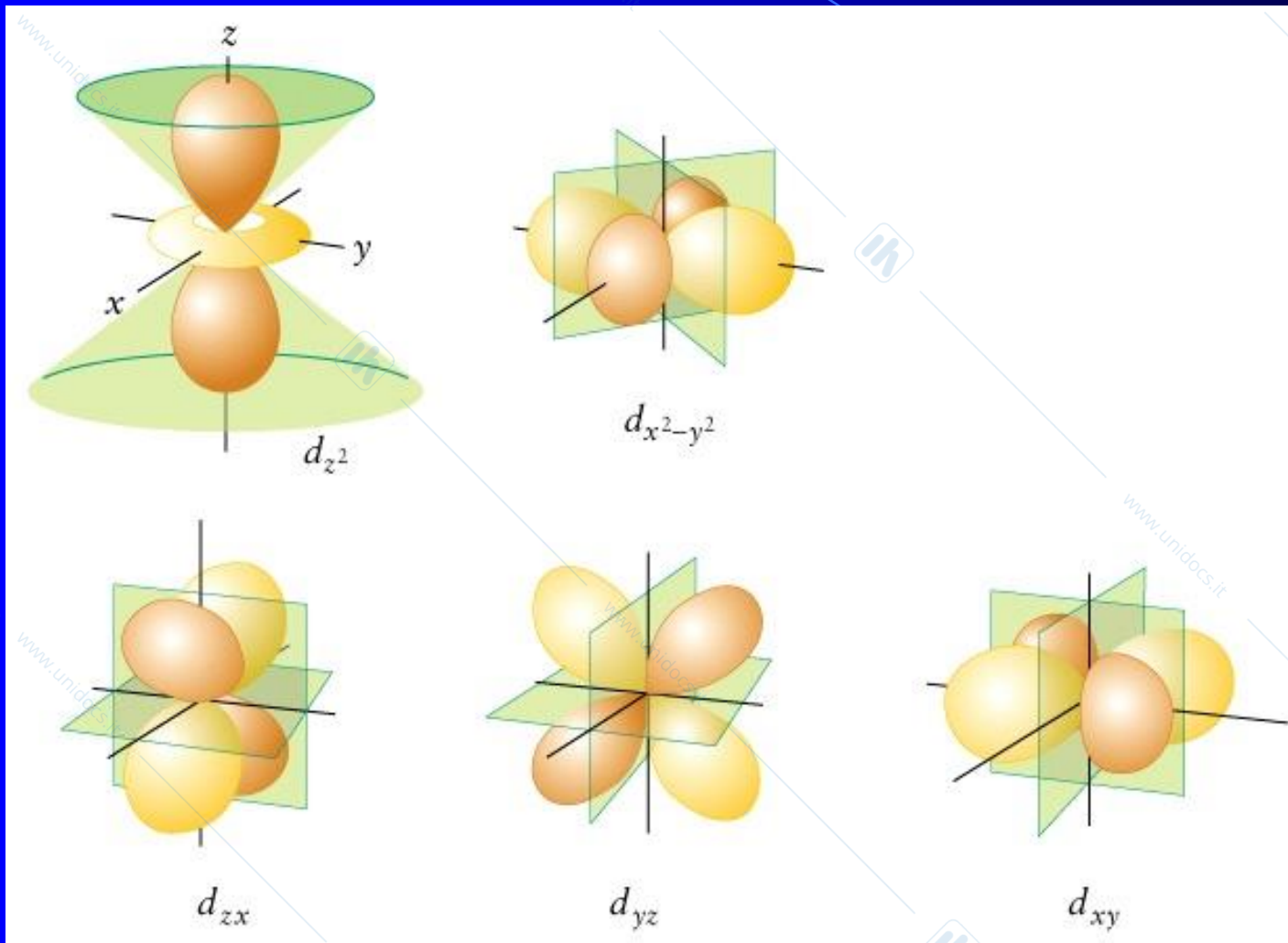

f orbitals

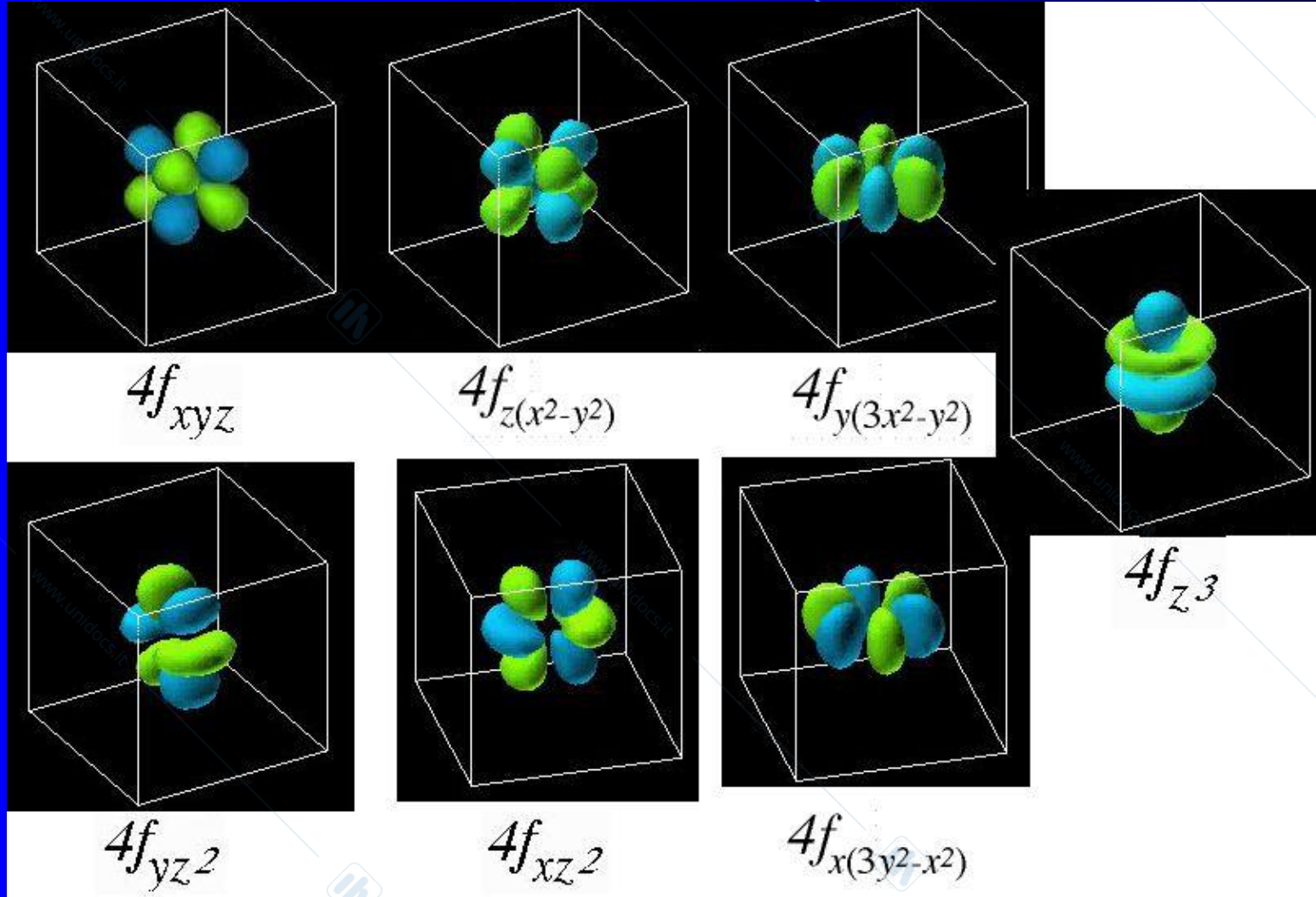

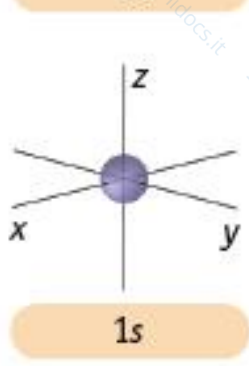
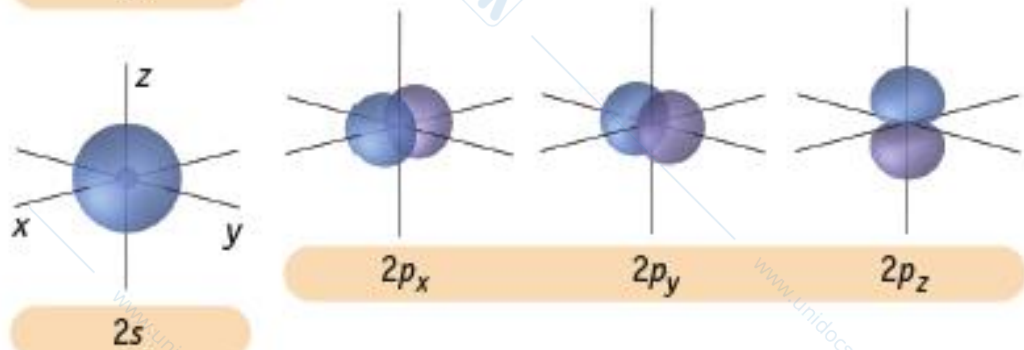
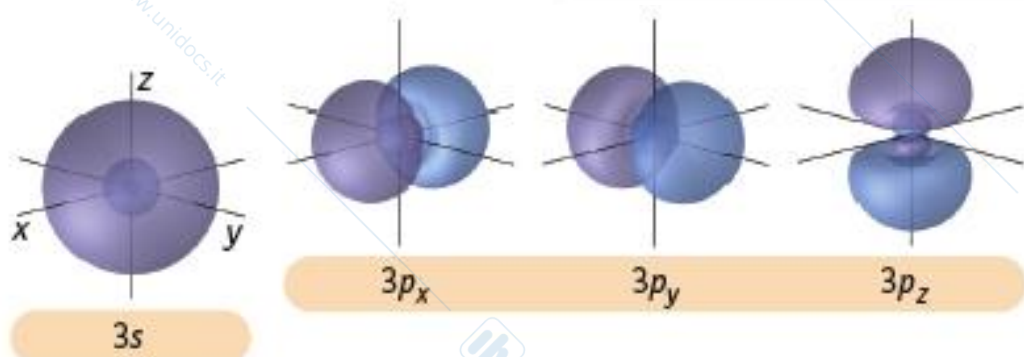
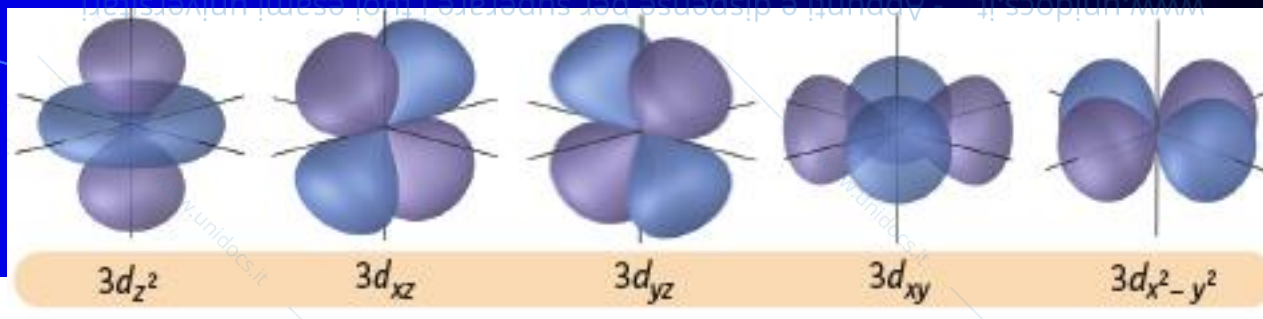

A Summary of Atomic Orbitals from 1s to 3d

Orbital Diagram

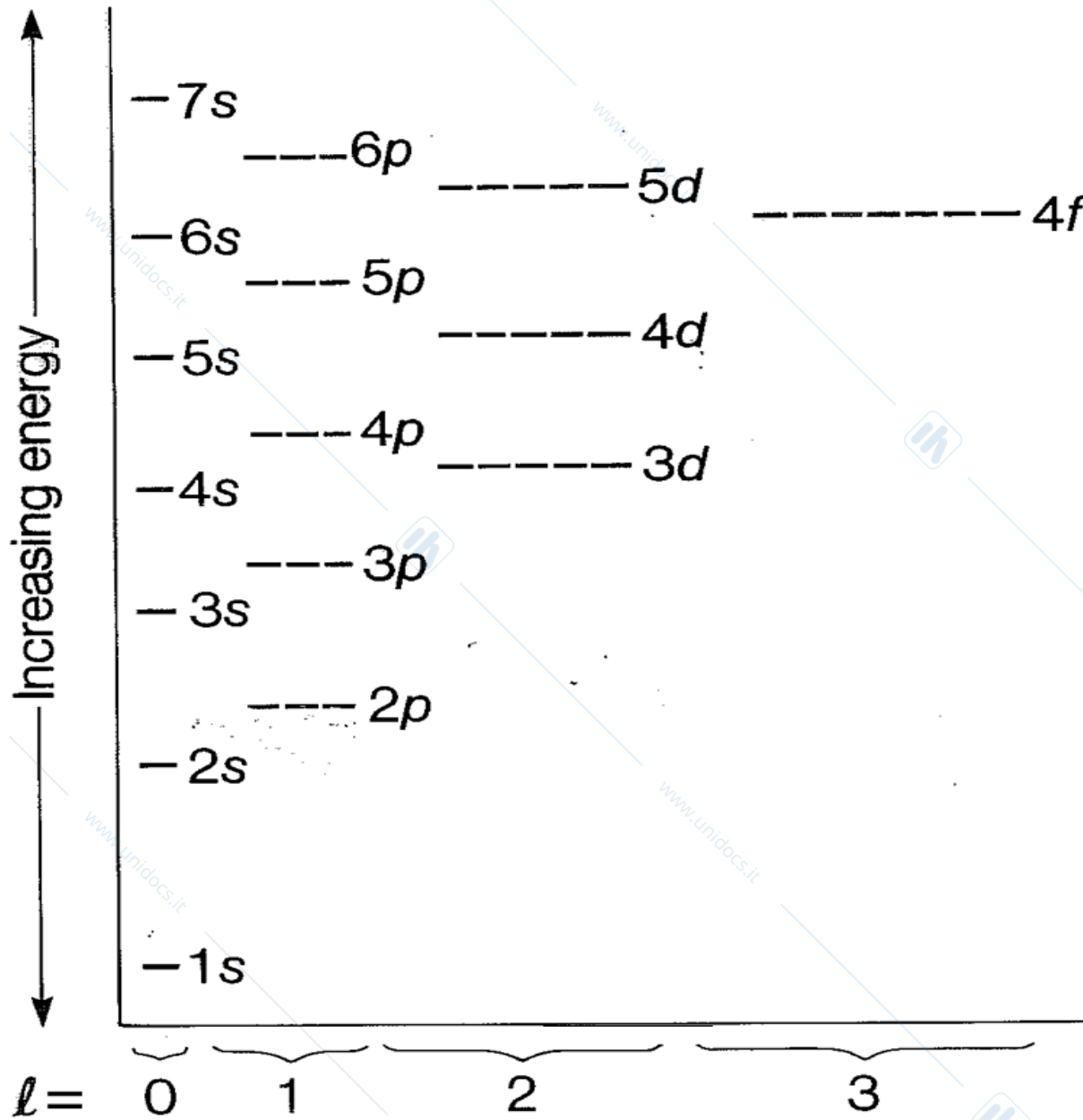

Filling Diagram for Sublevels

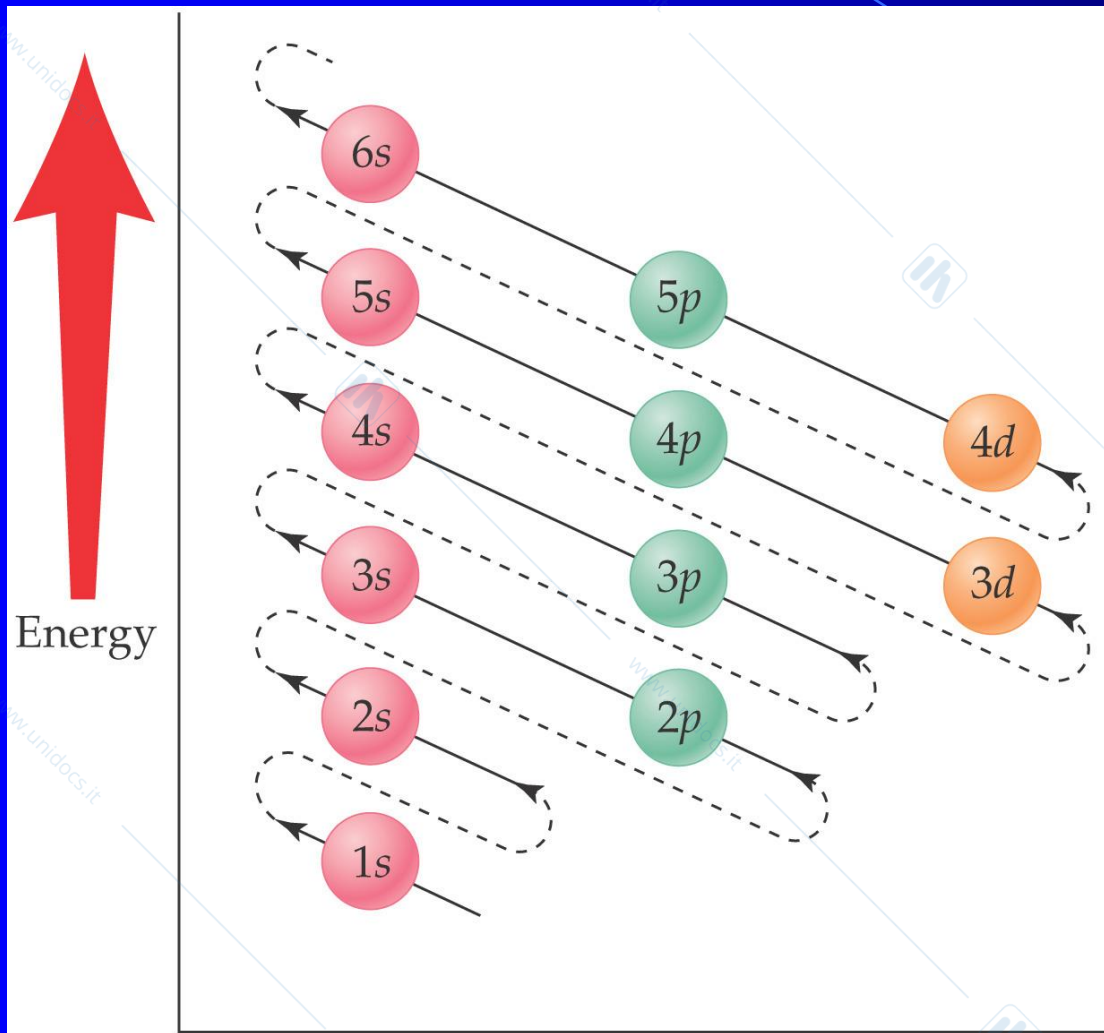

Aufbau Principle

Electron Configurations

- Definition
 - arrangement of electrons in the orbitals of an atom (similar to seating assignments on an airplane)
 - when all electrons at their lowest energies this is called ground state

Electron Configurations

- Electron configurations tells us in which orbitals the electrons for an element are located.
- Three rules:
 - electrons fill orbitals starting with lowest n and moving upwards;
 - no two electrons can fill one orbital with the same spin (Pauli);
 - for degenerate orbitals, electrons fill each orbital singly before any orbital gets a second electron (Hund's rule).

Electron Configurations

- The *electron configuration* of an atom is a shorthand method of writing the location of electrons by sublevel.
- The sublevel is written followed by a superscript with the number of electrons in the sublevel.
 - If the $2p$ sublevel contains 2 electrons, it is written $2p^2$

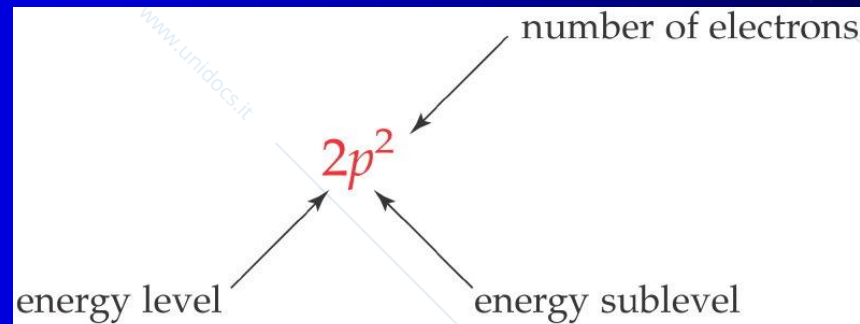

Copyright © 2005 Pearson Prentice Hall, Inc.

Writing Electron Configurations

- First, determine how many electrons are in the atom. Iron has 26 electrons.
- Arrange the energy sublevels according to increasing energy:
 - $1s\ 2s\ 2p\ 3s\ 3p\ 4s\ 3d\ \dots$
- Fill each sublevel with electrons until you have used all the electrons in the atom:
 - Fe: $1s^2\ 2s^2\ 2p^6\ 3s^2\ 3p^6\ 4s^2\ 3d^6$
- The sum of the superscripts equals the atomic number of iron (26)

Writing Atomic Electron Configurations

Two ways of writing configs. One is called the **spdf notation**.

spdf notation
for H, atomic number = 1

1 ← no. of electrons
s ← value of l
1 ← value of n

Writing Atomic Electron Configurations

Two ways of writing configs. Other is called the orbital box notation.

ORBITAL BOX NOTATION
for He, atomic number = 2

1 s²

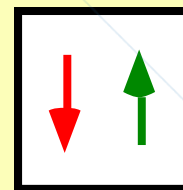

1s

Arrows depict electron spin

One electron has $n = 1, l = 0, m_l = 0, m_s = + 1/2$

Other electron has $n = 1, l = 0, m_l = 0, m_s = - 1/2$

Orbital Diagram

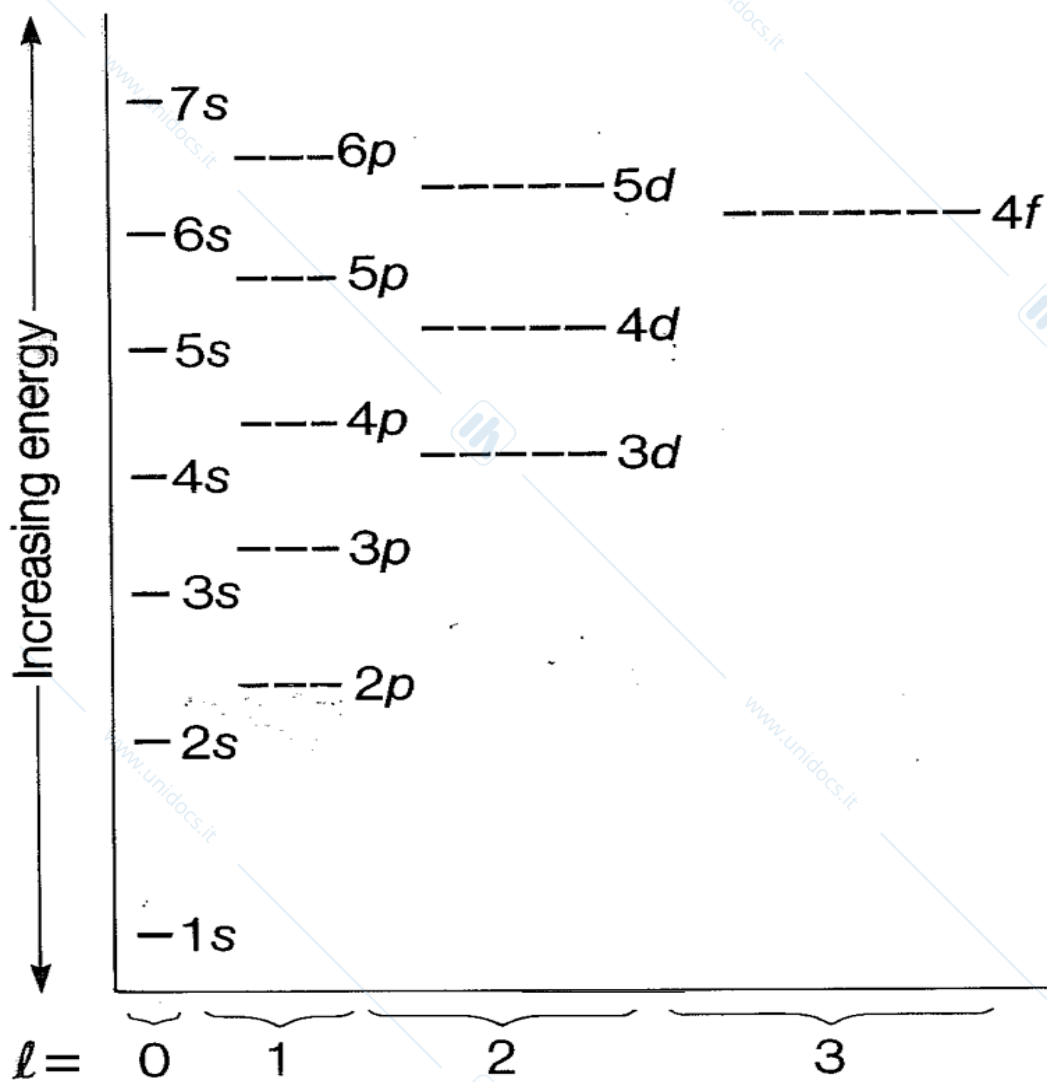

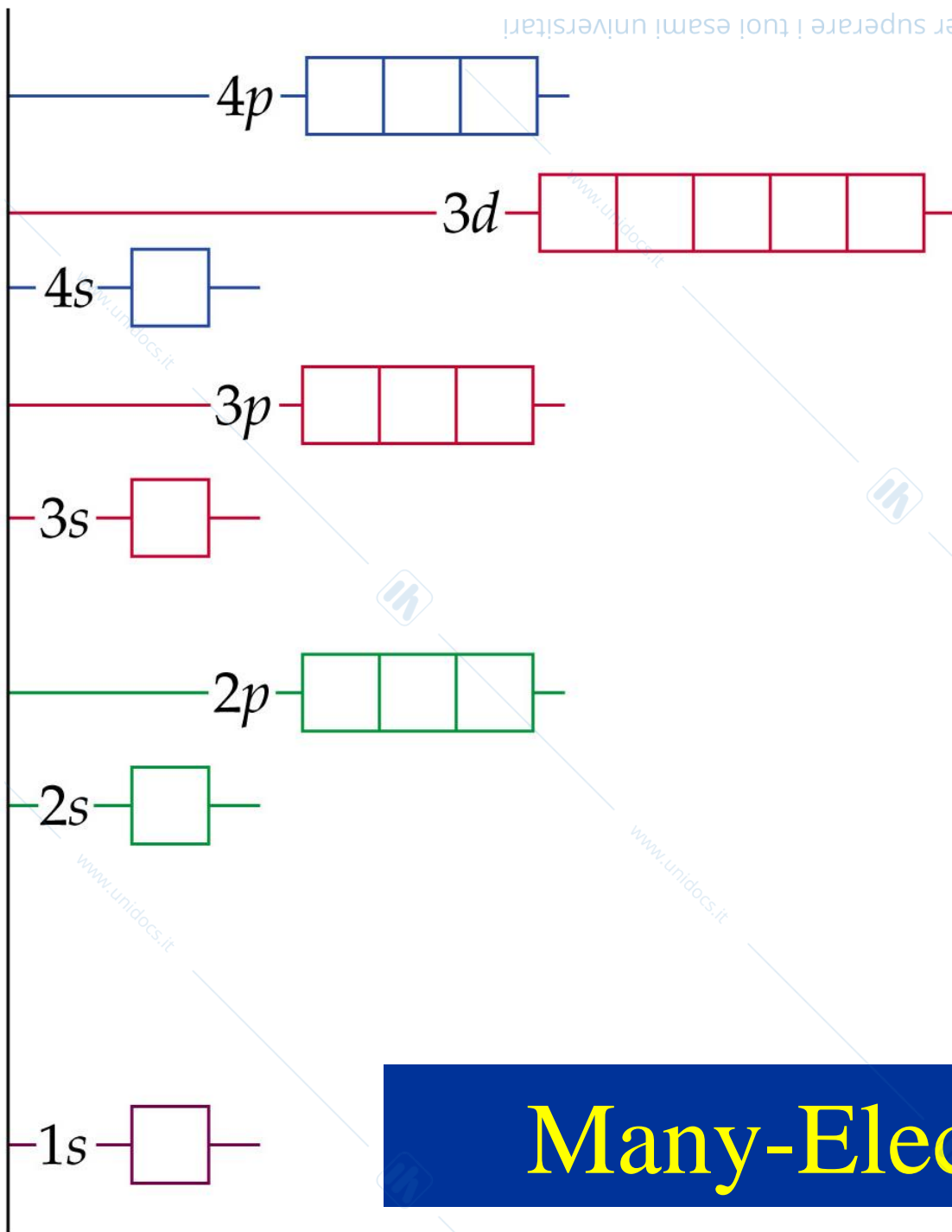

Orbitals and Their Energies

Many-Electron Atoms

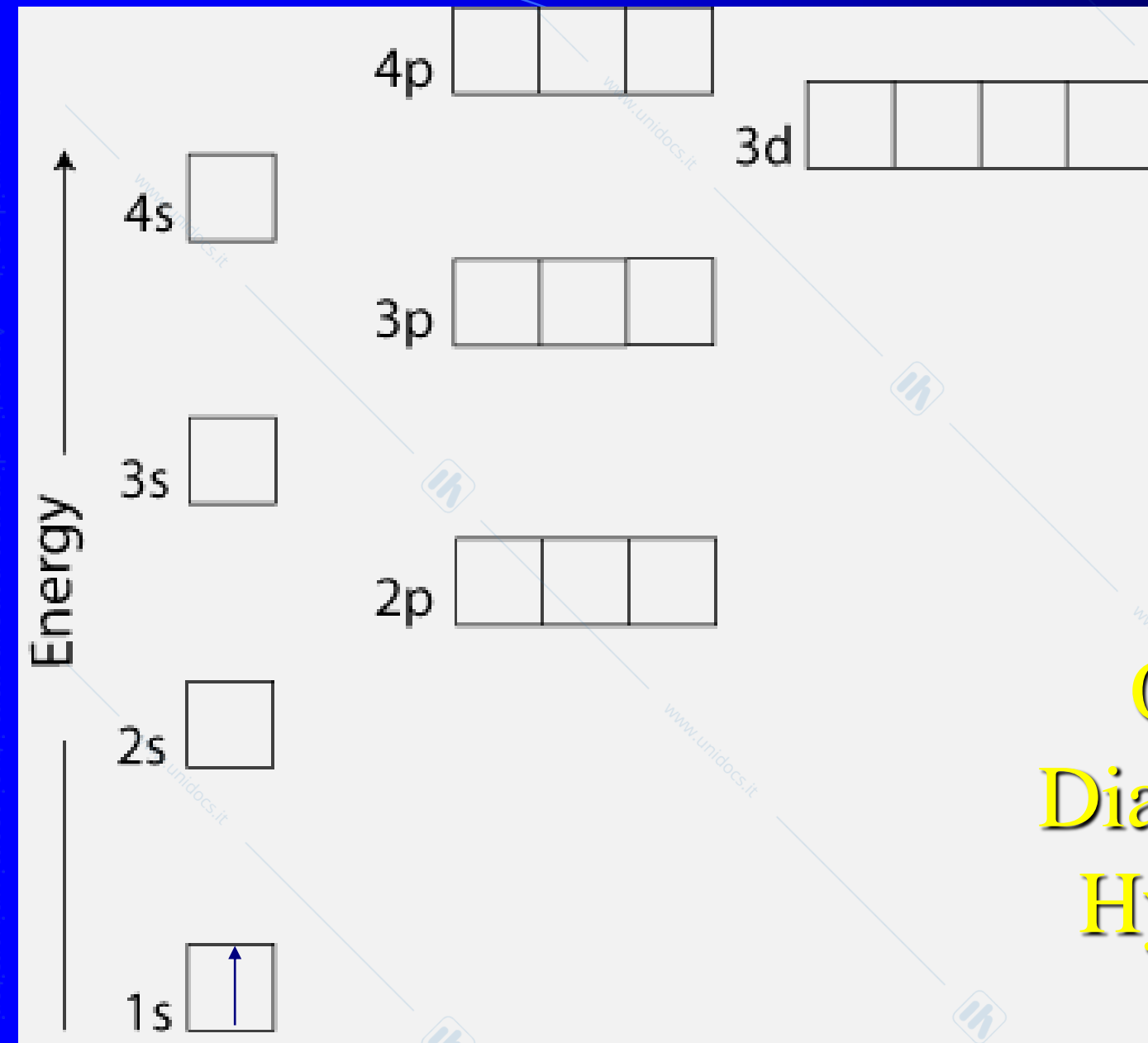

Orbital Diagram for Hydrogen

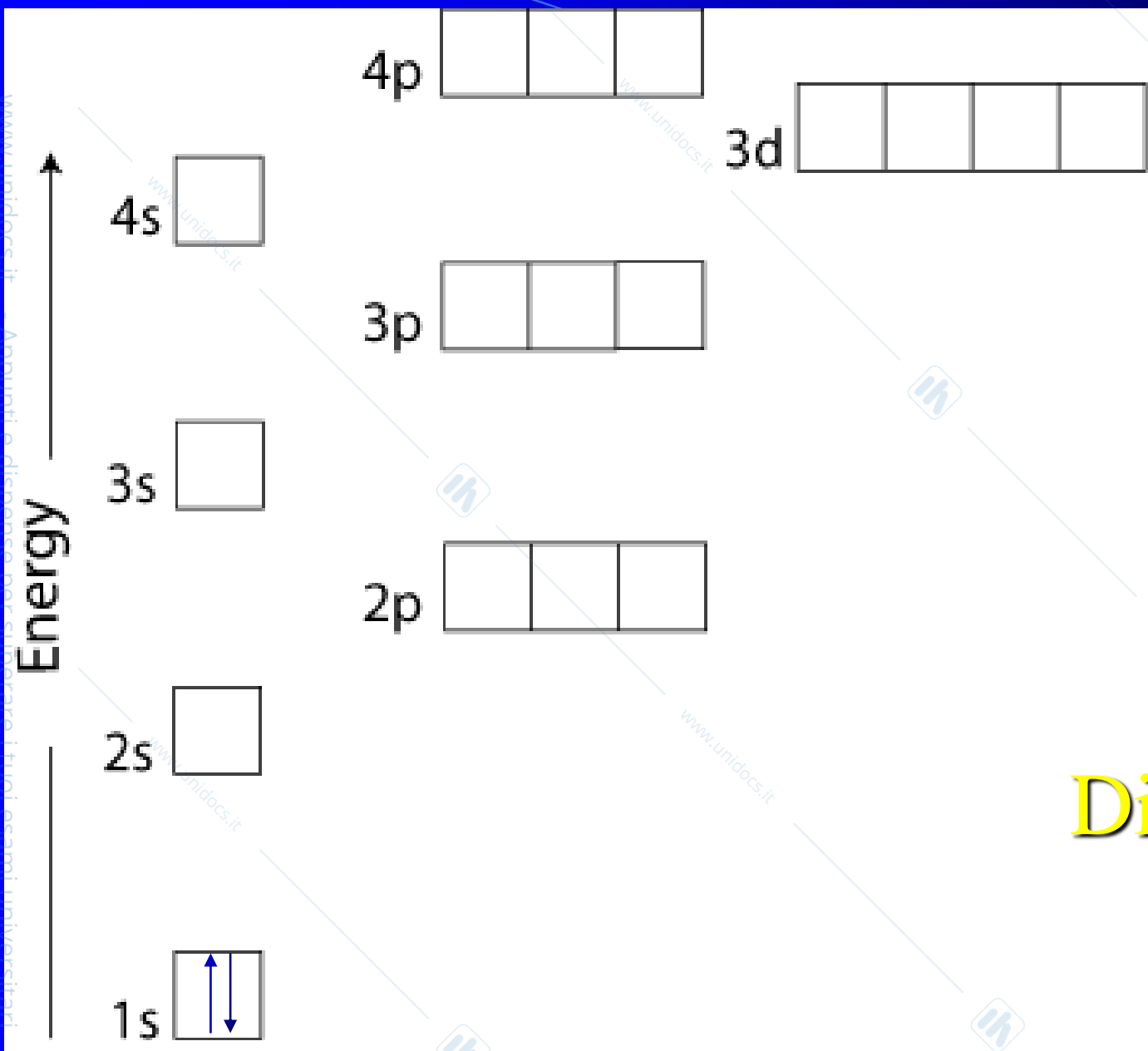

Orbital Diagram for Helium

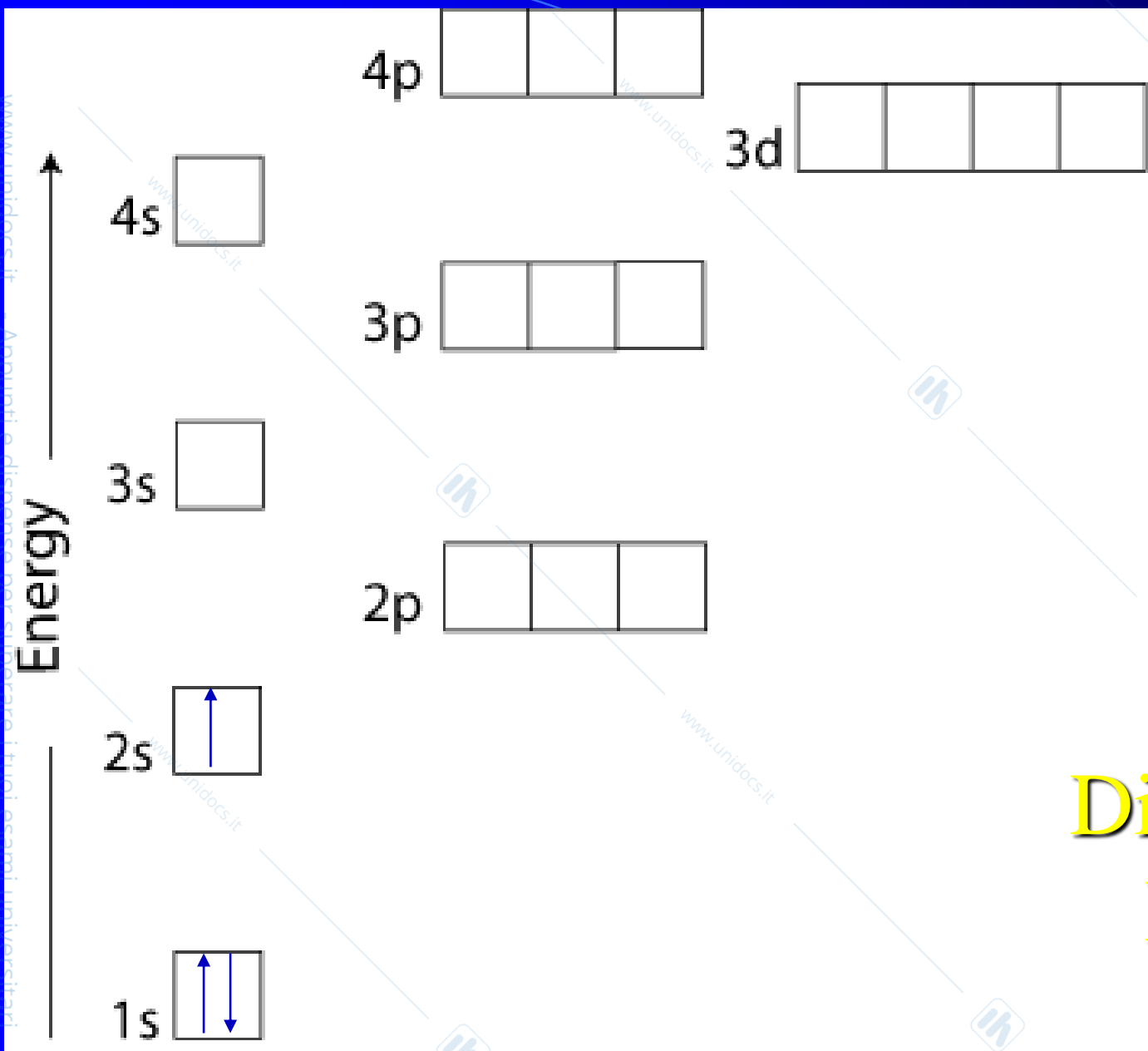

Orbital Diagram for Lithium

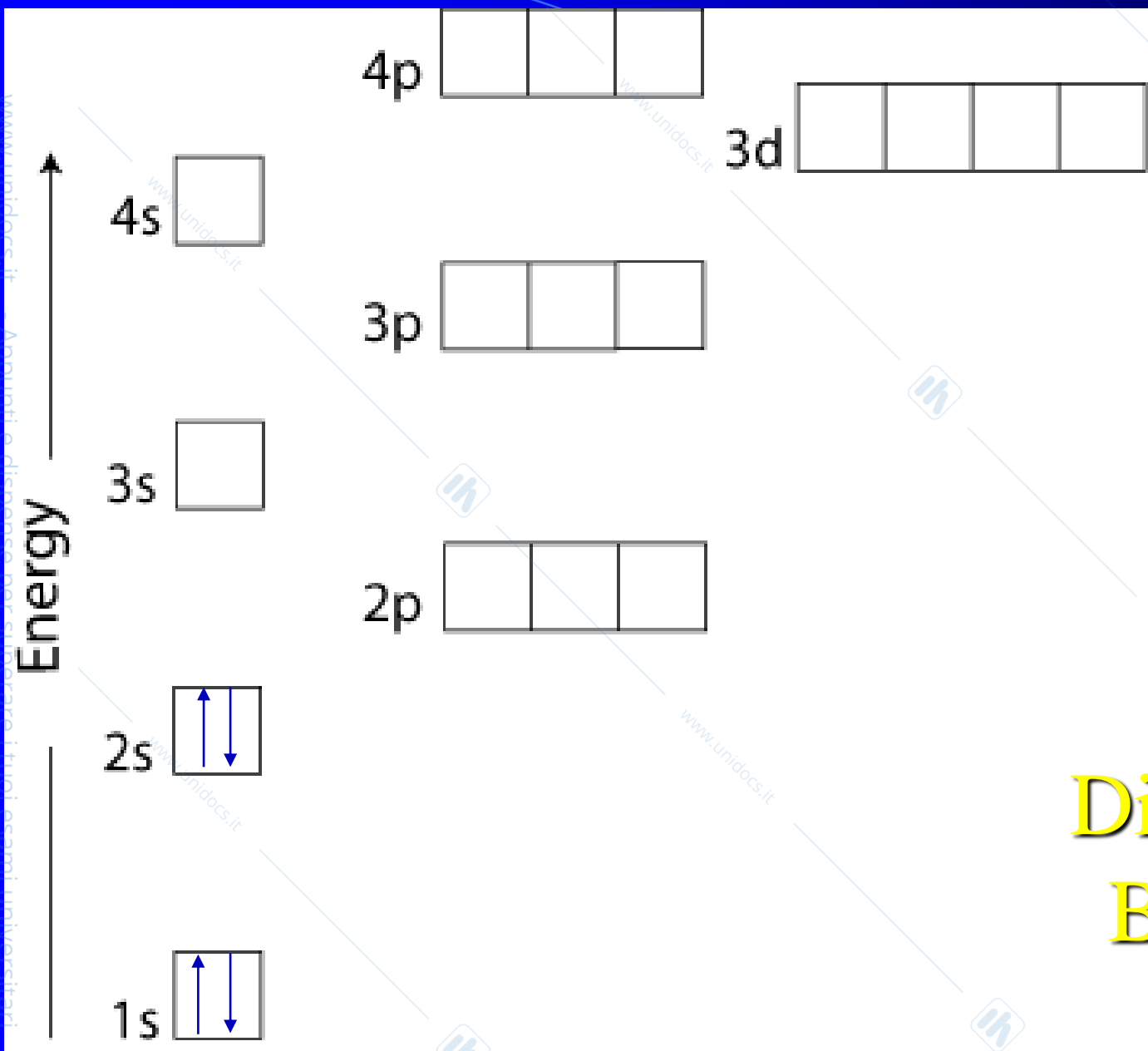

Orbital Diagram for Beryllium

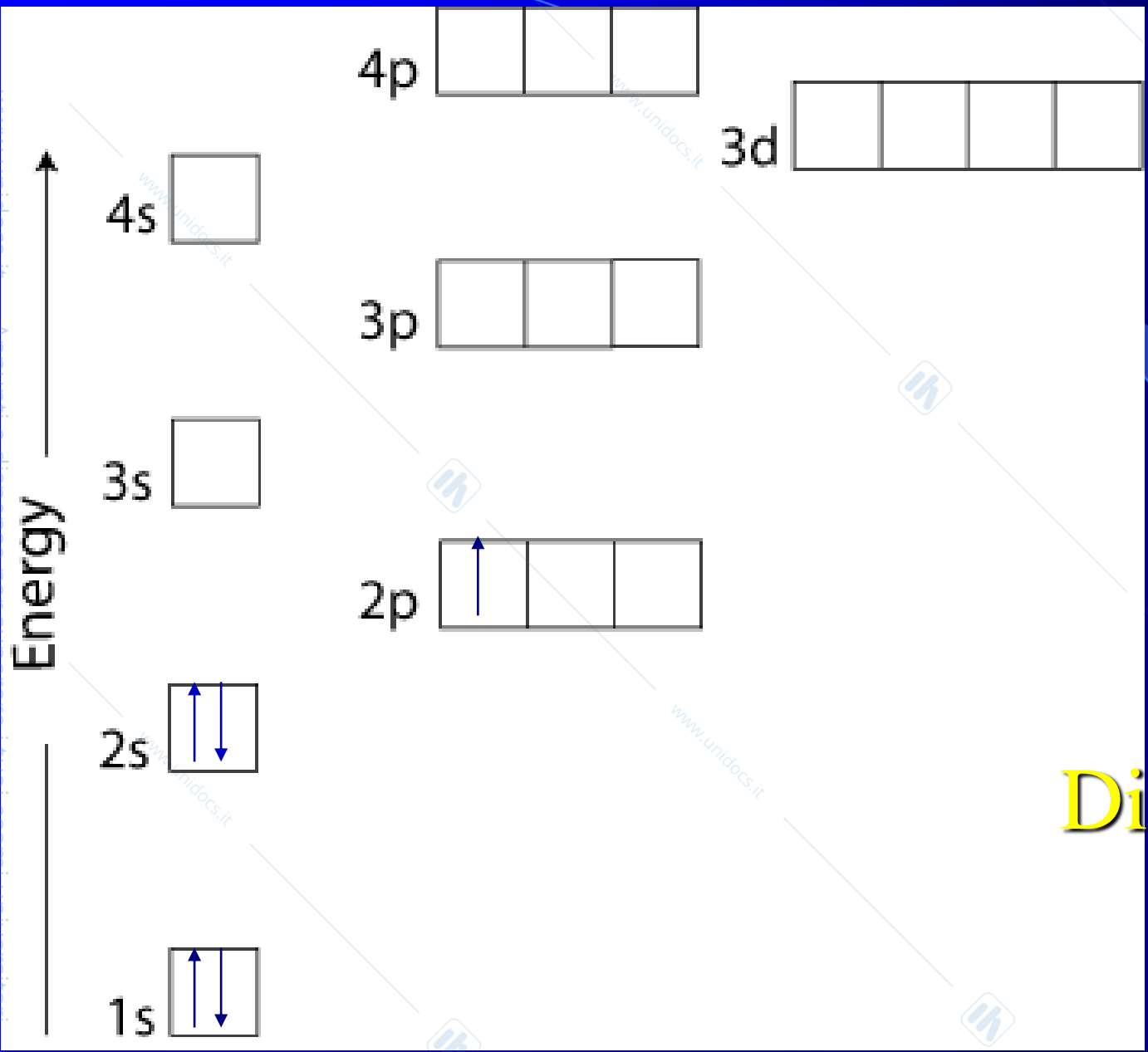

Orbital Diagram for Boron

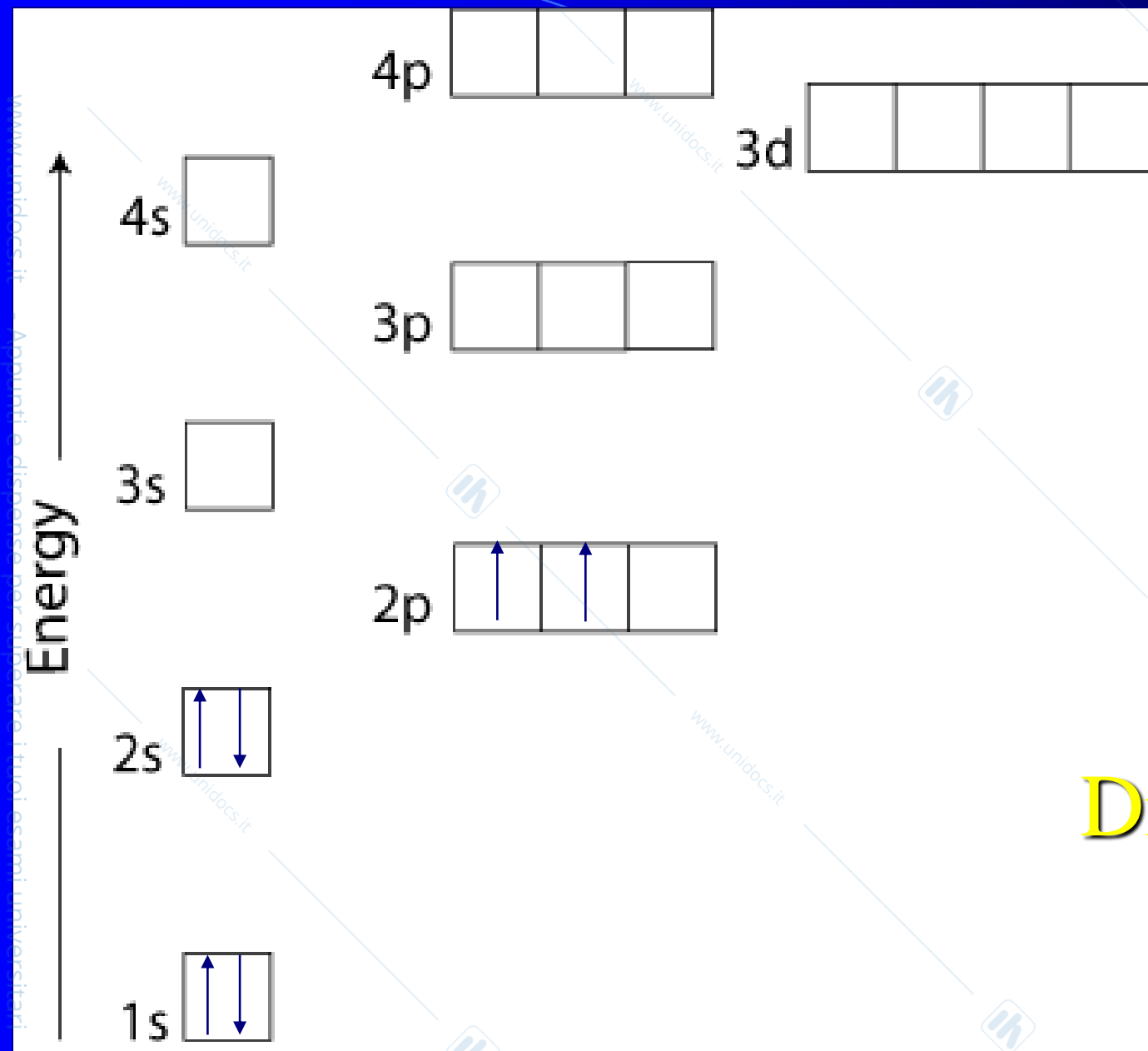

Orbital Diagram for Carbon

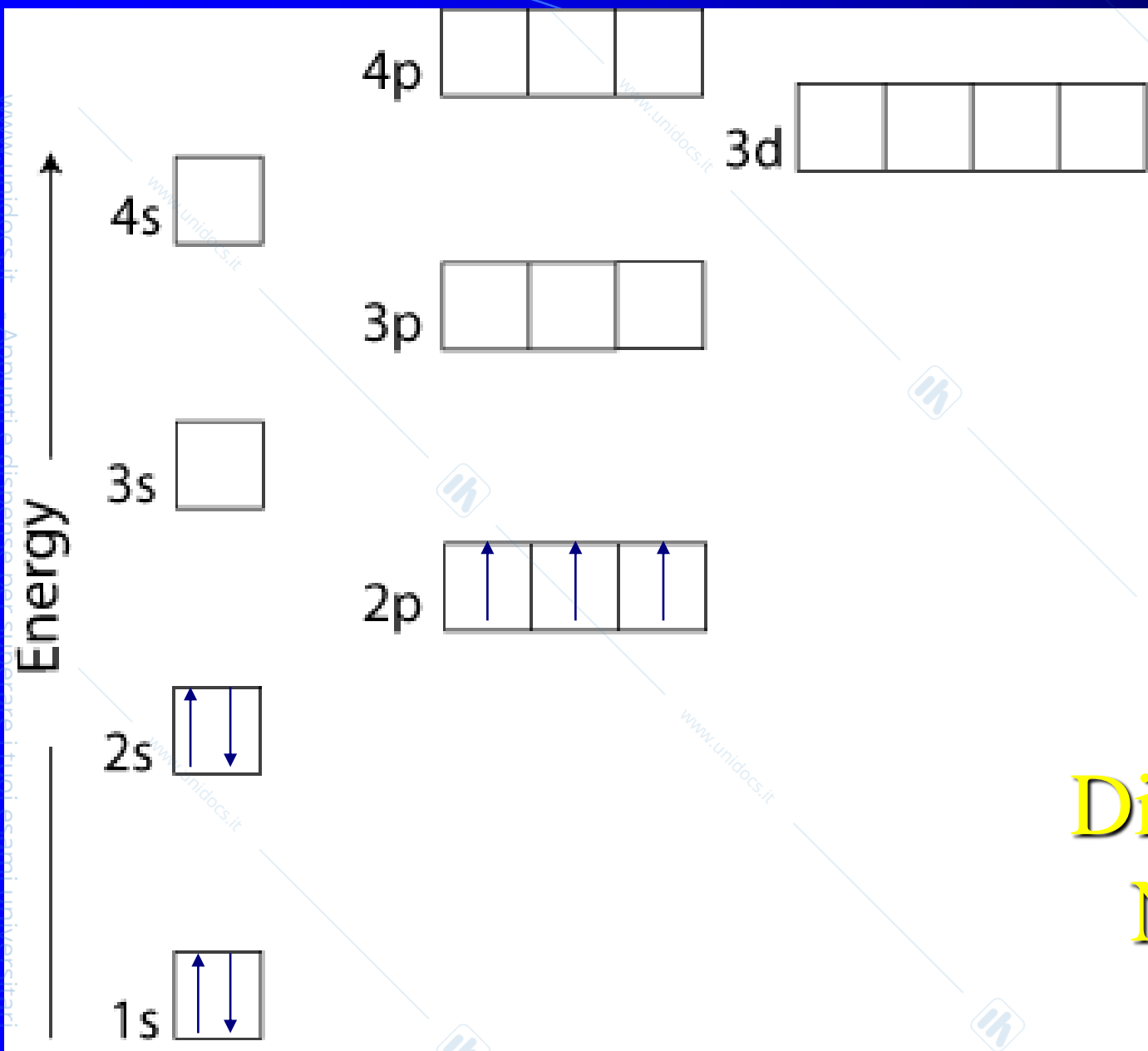

Orbital Diagram for Nitrogen

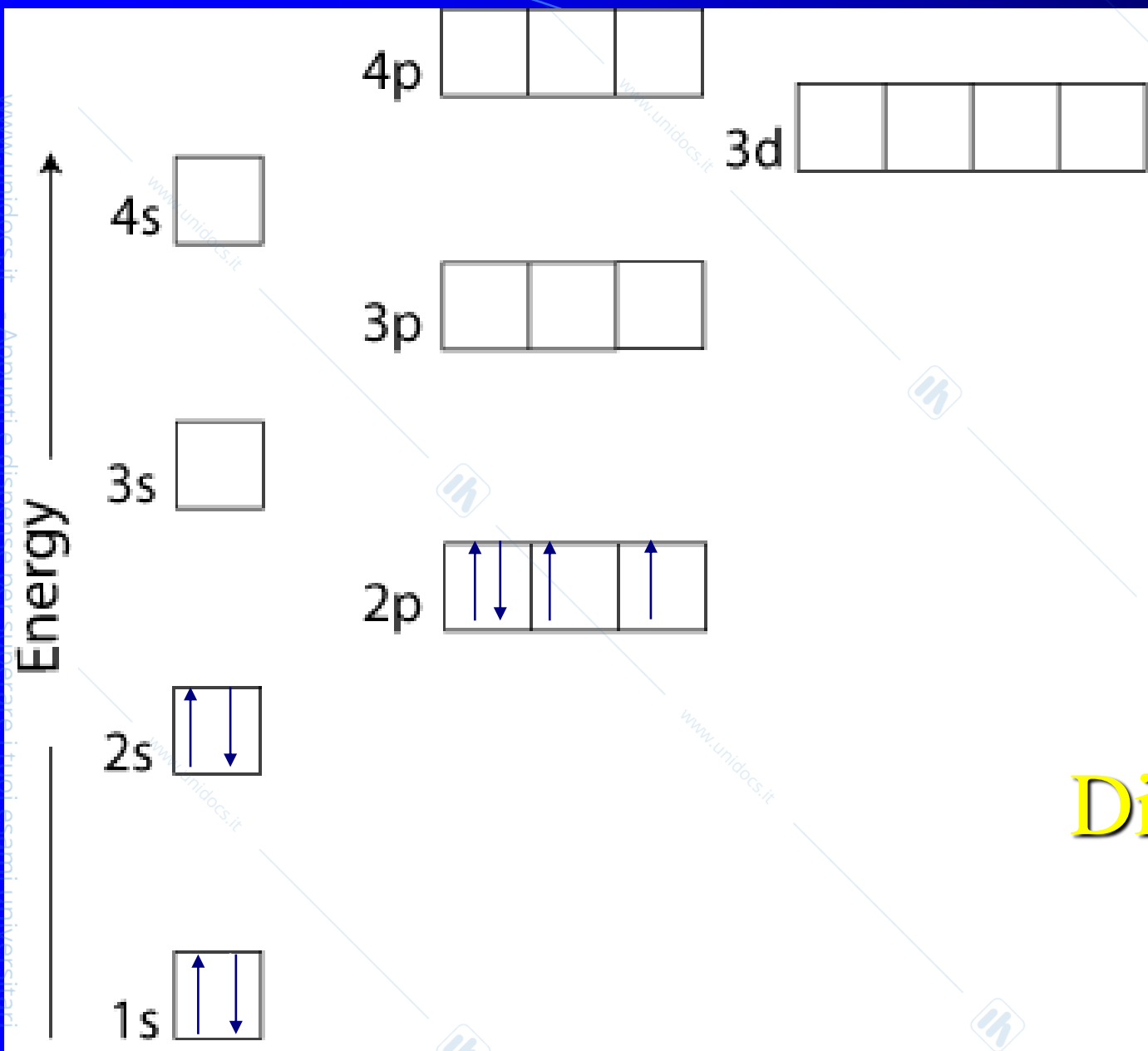

Orbital Diagram for Oxygen

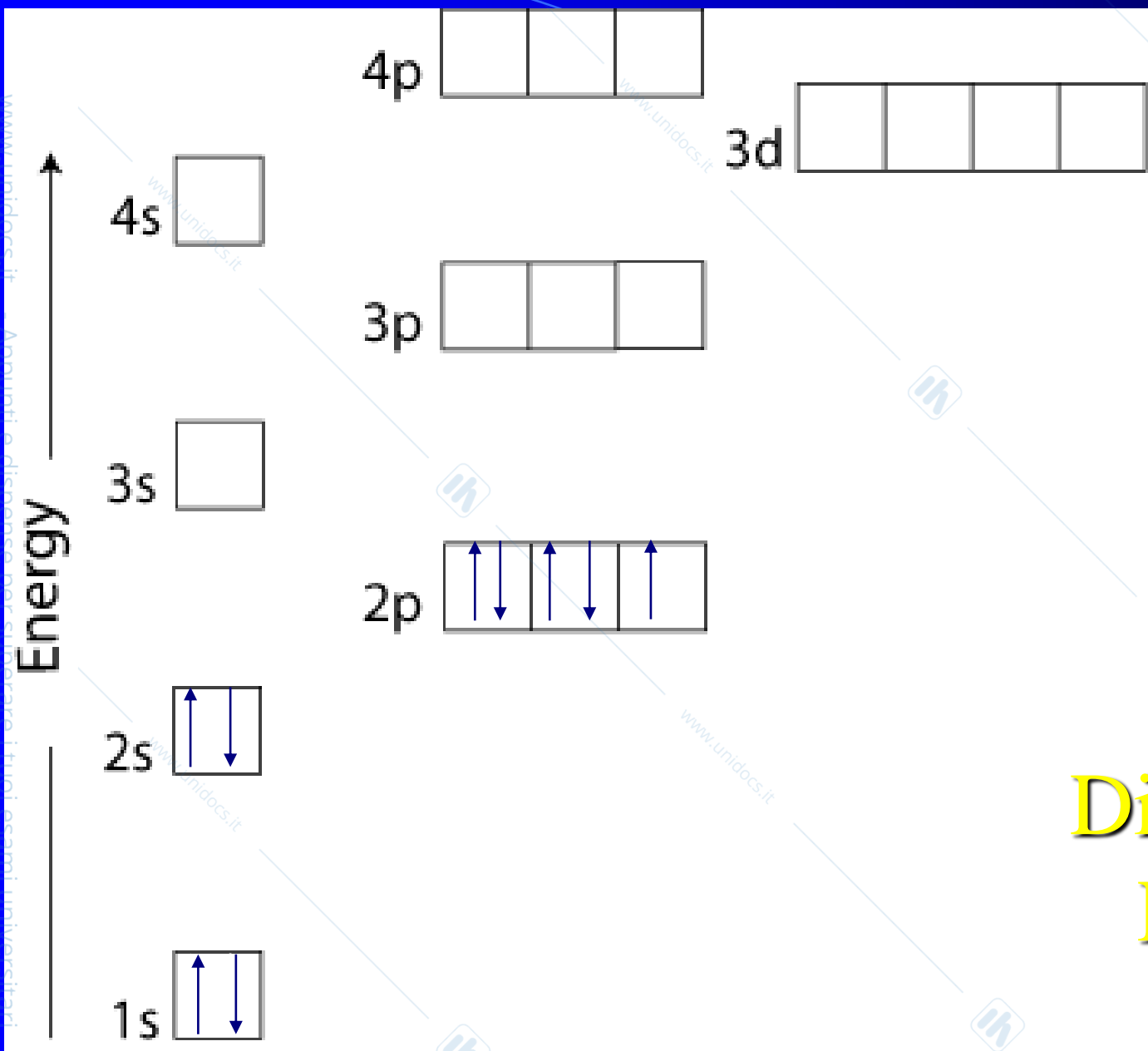

Orbital Diagram for Fluorine

Standard Notation of Fluorine

Number of electrons
in the sub level 2,2,5



Sublevels

Main Energy
Level
Numbers 1,
2, 2

Noble Gas Core Electron Configurations

- Recall, the electron configuration for Na is:



- We can abbreviate the electron configuration by indicating the innermost electrons with the symbol of the preceding noble gas.
- The preceding noble gas with an atomic number less than sodium is neon, Ne. We rewrite the electron configuration:



Organizing the Elements by Electron Configuration

	1	2	13	14	15	16	17	18
1	H·							He:
2	Li·	Be·	·B·	·C·	·N·	·O·	·F·	·Ne:
3	Na·	Mg·	·Al·	·Si·	·P·	·S·	·Cl·	·Ar:
4	K·	Ca·	·Ga·	·Ge·	·As·	·Se·	·Br·	·Kr:
5	Rb·	Sr·	·In·	·Sn·	·Sb·	·Te·	·I·	·Xe:
6	Cs·	Ba·	·Tl·	·Pb·	·Bi·	·Po·		·Rn:

		gruppo																							
		1	2	3	4	5	6	7	8	9	10	11	12	13	14	15	16	17	18						
periodo	1	IA 1 1,008 H Idrogeno																	VIII A 2 4 He Elio						
	2	3 6,941 Li Litio	4 9,012 Be Berillio																	5 10,81 B Boro	6 12,01 C Carbonio	7 14,01 N Azoto	8 16 O Ossigeno	9 19 F Fluoro	10 20,18 Ne Neon
	3	11 22,99 Na Sodio	12 24,31 Mg Magnesio			13 26,98 Al Alluminio	14 28,09 Si Silicio	15 30,97 P Fosforo	16 32,06 S Zolfo	17 35,45 Cl Cloro	18 39,95 Ar Argon														
	4	19 39,10 K Potassio	20 40,08 Ca Calcio	21 44,96 Sc Scandio	22 47,88 Ti Titanio	23 50,94 V Vanadio	24 52 Cr Cromo	25 54,94 Mn Manganese	26 55,85 Fe Ferro	27 58,93 Co Cobalto	28 58,69 Ni Nichel	29 63,55 Cu Rame	30 65,39 Zn Zinco	31 69,72 Ga Gallio	32 72,57 Ge Germanio	33 76,92 As Arsenico	34 78,96 Se Selenio	35 79,90 Br Bromo	36 83,80 Kr Kriptone						
	5	37 85,47 Rb Rubidio	38 87,62 Sr Stronzio	39 88,91 Y Ittrio	40 91,22 Zr Zirconio	41 92,91 Nb Niobio	42 95,94 Mo Molibdeno	43 98 Tc Tecnecio	44 101,1 Ru Rutenio	45 102,9 Rh Rodio	46 106,4 Pd Palladio	47 107,9 Ag Argento	48 112,4 Cd Cadmio	49 114,5 In Indio	50 118,7 Sn Stagno	51 121,8 Sb Antimonio	52 127,6 Te Tellurio	53 126,9 I Iodio	54 131,3 Xe Xenone						
	6	55 132,9 Cs Cesio	56 137,3 Ba Bario	57 138,9 La Lantanio	58 178,5 Hf Hafnio	59 180,5 Ta Tantalio	60 183,9 W Wolframio	61 186,2 Re Reniio	62 190,2 Os Osmio	63 192,2 Ir Iridio	64 195,1 Pt Platino	65 197 Au Oro	66 200,6 Hg Mercurio	67 204,4 Tl Tallio	68 207,2 Pb Piombo	69 209 Bi Bismuto	70 209 Po Polonio	71 210 At Astatina	72 222 Rn Radone						
	7	87 223 Fr Francio	88 226 Ra RADIO	89 227 Ac Attinio	90 267 Rf Rutherfordio	91 268 Db Dubnio	92 268 Sg Seaborgio	93 268 Bh Bohrio	94 268 Hs Hassium	95 268 Mt Meitnerio	96 268 Ds Darmstadtio	97 268 Rg Roentgenio	98 268 Cn Copernicio												

• Lantanoidi

58 140,1 Ce Cerio	59 140,9 Pr Praseodimio	60 144,2 Nd Neodimio	61 145 Pm Prometio	62 150,4 Sm Samarbio	63 152 Eu Europio	64 157,3 Gd Gadolino	65 158,9 Tb Terbio	66 162,5 Dy Dizidio	67 164,9 Ho Olimio	68 167,3 Er Erbio	69 168,9 Tm Tulio	70 173 Yb Ytterbio	71 175 Lu Lutetio
--------------------------------	--------------------------------------	-----------------------------------	---------------------------------	-----------------------------------	--------------------------------	-----------------------------------	---------------------------------	----------------------------------	---------------------------------	--------------------------------	--------------------------------	---------------------------------	--------------------------------

•• Attinoidi

90 232 Th Torio	91 231 Pa Protattinio	92 238 U Uranio	93 237 Np Neptunio	94 244 Pu Plutonio	95 243 Am Americio	96 247 Cm Curio	97 247 Bk Berkelio	98 251 Cf Californio	99 252 Es Einsteinio	100 257 Fm Fermio	101 258 Md Mendelevio	102 259 No Nobelio	103 260 Lr Lawrencio
------------------------------	------------------------------------	------------------------------	---------------------------------	---------------------------------	---------------------------------	------------------------------	---------------------------------	-----------------------------------	-----------------------------------	--------------------------------	------------------------------------	---------------------------------	-----------------------------------

Figura 3.3. Una Tavola Periodica completa di nome degli elementi, numeri atomici Z e di massa A.

Blocks and Sublevels

- We can use the periodic table to predict which sublevel is being filled by a particular element.

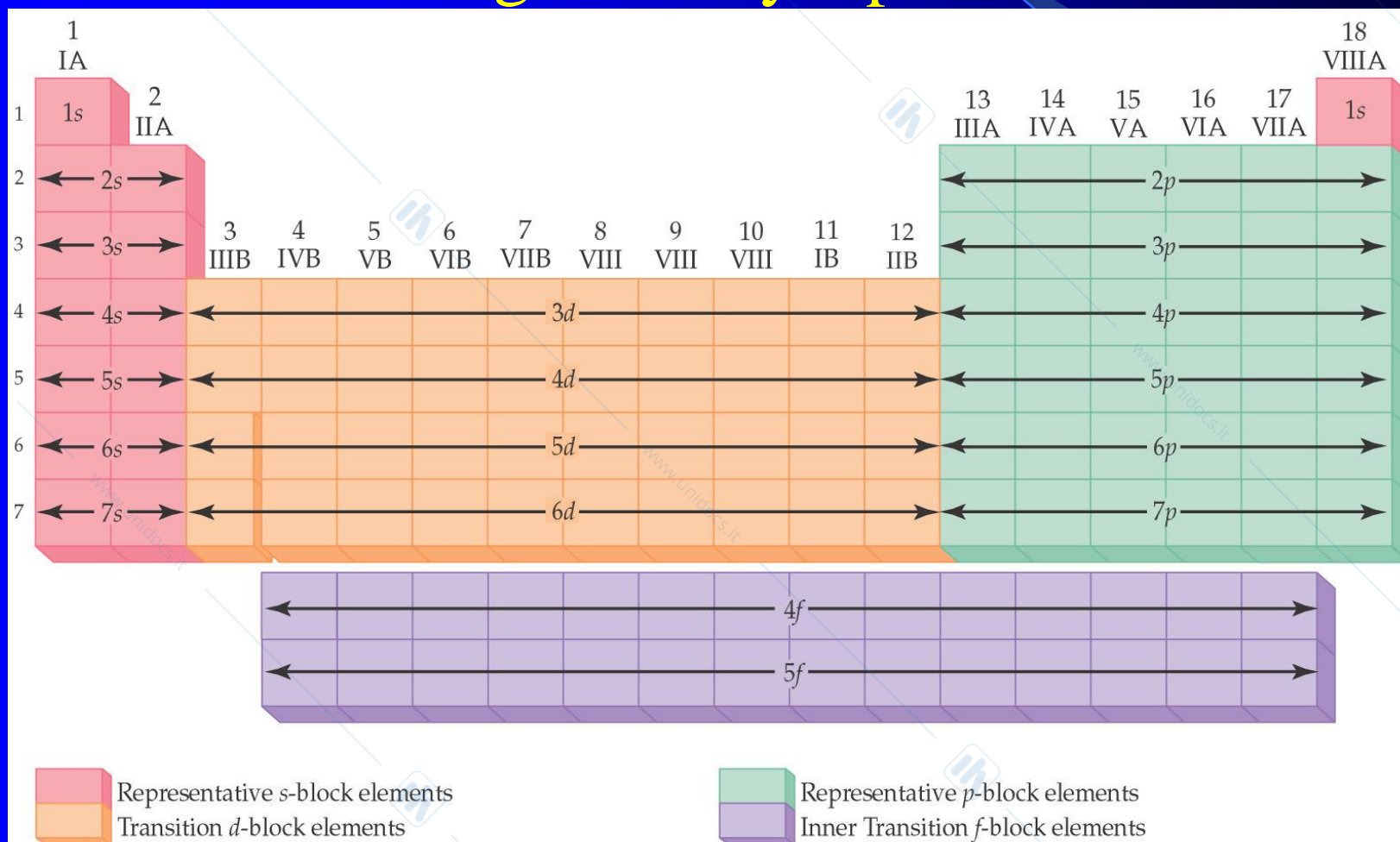

Electron Configurations and the Periodic Table

- The periodic table can be used as a guide for electron configurations.
- The period number is the value of n .
- Groups 1A and 2A have the s -orbital filled.
- Groups 3A - 8A have the p -orbital filled.
- Groups 3B - 2B have the d -orbital filled.
- The lanthanides and actinides have the f -orbital filled.

s												p					He
H												B	C	N	O	F	Ne
Li	Be											Al	Si	P	S	Cl	Ar
		d															
Na	Mg	Sc	Ti	V	Cr	Mn	Fe	Co	Ni	Cu	Zn	Ga	Ge	As	Se	Br	Kr
K	Ca	Y	Zr	Nb	Mo	Tc	Ru	Rh	Pd	Ag	Cd	In	Sn	Sb	Te	I	Xe
Rb	Sr	La	Hf	Ta	W	Re	Os	Ir	Pt	Au	Hg	Tl	Pb	Bi	Po	At	Rn
Cs	Ba																
Fr	Ra	Ac															

f													
Ce	Pr	Nd	Pm	Sm	Eu	Gd	Tb	Dy	Ho	Er	Tm	Yb	Lu
Th	Pa	U	Np	Pu	Am	Cm	Bk	Cf	Es	Fm	Md	No	Lr

Figura 3.5. Classificazione della Tavola Periodica degli elementi per sottolivelli.

	1A 1																	8A 18						
Core	1 H 1s ¹	2A 2																	2 He 1s ²					
[He]	3 Li 2s ¹	4 Be 2s ²																	5 B 2s ² 2p ¹	6 C 2s ² 2p ²	7 N 2s ² 2p ³	8 O 2s ² 2p ⁴	9 F 2s ² 2p ⁵	10 Ne 2s ² 2p ⁶
[Ne]	11 Na 3s ¹	12 Mg 3s ²	3B 3	4B 4	5B 5	6B 6	7B 7	8B 8 9 10			1B 11	2B 12	13 Al 3s ² 3p ¹	14 Si 3s ² 3p ²	15 P 3s ² 3p ³	16 S 3s ² 3p ⁴	17 Cl 3s ² 3p ⁵	18 Ar 3s ² 3p ⁶						
[Ar]	19 K 4s ¹	20 Ca 4s ²	21 Sc 3d ¹ 4s ²	22 Ti 3d ² 4s ²	23 V 3d ³ 4s ²	24 Cr 3d ⁵ 4s ¹	25 Mn 3d ⁵ 4s ²	26 Fe 3d ⁶ 4s ²	27 Co 3d ⁷ 4s ²	28 Ni 3d ⁸ 4s ²	29 Cu 3d ¹⁰ 4s ¹	30 Zn 3d ¹⁰ 4s ²	31 Ga 3d ¹⁰ 4s ² 4p ¹	32 Ge 3d ¹⁰ 4s ² 4p ²	33 As 3d ¹⁰ 4s ² 4p ³	34 Se 3d ¹⁰ 4s ² 4p ⁴	35 Br 3d ¹⁰ 4s ² 4p ⁵	36 Kr 3d ¹⁰ 4s ² 4p ⁶						
[Kr]	37 Rb 5s ¹	38 Sr 5s ²	39 Y 4d ¹ 5s ²	40 Zr 4d ² 5s ²	41 Nb 4d ⁴ 5s ¹	42 Mo 4d ⁵ 5s ¹	43 Tc 4d ⁵ 5s ²	44 Ru 4d ⁷ 5s ¹	45 Rh 4d ⁸ 5s ¹	46 Pd 4d ¹⁰	47 Ag 4d ¹⁰ 5s ¹	48 Cd 4d ¹⁰ 5s ²	49 In 4d ¹⁰ 5s ² 5p ¹	50 Sn 4d ¹⁰ 5s ² 5p ²	51 Sb 4d ¹⁰ 5s ² 5p ³	52 Te 4d ¹⁰ 5s ² 5p ⁴	53 I 4d ¹⁰ 5s ² 5p ⁵	54 Xe 4d ¹⁰ 5s ² 5p ⁶						
[Xe]	55 Cs 6s ¹	56 Ba 6s ²	71 Lu 4f ¹⁴ 5d ¹ 6s ²	72 Hf 4f ¹⁴ 5d ² 6s ²	73 Ta 4f ¹⁴ 5d ³ 6s ²	74 W 4f ¹⁴ 5d ⁴ 6s ²	75 Re 4f ¹⁴ 5d ⁵ 6s ²	76 Os 4f ¹⁴ 5d ⁶ 6s ²	77 Ir 4f ¹⁴ 5d ⁷ 6s ²	78 Pt 4f ¹⁴ 5d ⁹ 6s ¹	79 Au 4f ¹⁴ 5d ¹⁰ 6s ¹	80 Hg 4f ¹⁴ 5d ¹⁰ 6s ²	81 Tl 4f ¹⁴ 5d ¹⁰ 6s ² 6p ¹	82 Pb 4f ¹⁴ 5d ¹⁰ 6s ² 6p ²	83 Bi 4f ¹⁴ 5d ¹⁰ 6s ² 6p ³	84 Po 4f ¹⁴ 5d ¹⁰ 6s ² 6p ⁴	85 At 4f ¹⁴ 5d ¹⁰ 6s ² 6p ⁵	86 Rn 4f ¹⁴ 5d ¹⁰ 6s ² 6p ⁶						
[Rn]	87 Fr 7s ¹	88 Ra 7s ²	103 Lr 5f ¹⁴ 6d ¹ 7s ²	104 Rf 5f ¹⁴ 6d ² 7s ²	105 Db 5f ¹⁴ 6d ³ 7s ²	106 Sg 5f ¹⁴ 6d ⁴ 7s ²	107 Bh 5f ¹⁴ 6d ⁵ 7s ²	108 Hs 5f ¹⁴ 6d ⁶ 7s ²	109 Mt 5f ¹⁴ 6d ⁷ 7s ²	110	111	112		114		116								

[Xe]	Lanthanide series	57 La 5d ¹ 6s ²	58 Ce 4f ¹ 5d ¹ 6s ²	59 Pr 4f ³ 6s ²	60 Nd 4f ⁷ 6s ²	61 Pm 4f ⁵ 6s ²	62 Sm 4f ⁶ 6s ²	63 Eu 4f ⁷ 6s ²	64 Gd 4f ⁷ 5d ¹ 6s ²	65 Tb 4f ⁹ 6s ²	66 Dy 4f ¹⁰ 6s ²	67 Ho 4f ¹¹ 6s ²	68 Er 4f ¹² 6s ²	69 Tm 4f ¹³ 6s ²	70 Yb 4f ¹⁴ 6s ²
[Rn]	Actinide series	89 Ac 6d ¹ 7s ²	90 Th 6d ² 7s ²	91 Pa 5f ² 6d ¹ 7s ²	92 U 5f ³ 6d ¹ 7s ²	93 Np 5f ⁴ 6d ¹ 7s ²	94 Pu 5f ⁶ 7s ²	95 Am 5f ⁷ 7s ²	96 Cm 5f ⁷ 6d ¹ 7s ²	97 Bk 5f ⁹ 7s ²	98 Cf 5f ¹⁰ 7s ²	99 Es 5f ¹¹ 7s ²	100 Fm 5f ¹² 7s ²	101 Md 5f ¹³ 7s ²	102 No 5f ¹⁴ 7s ²

Metals
 Metalloids
 Nonmetals

Metals, Nonmetals, and Metalloids

Metals

1A												7A				8A	
H ⁺															H ⁻	NOBLE GASES	
Li ⁺														N ³⁻	O ²⁻		F ⁻
Na ⁺	Mg ²⁺	Transition metals										Al ³⁺		P ³⁻	S ²⁻		Cl ⁻
K ⁺	Ca ²⁺				Cr ³⁺	Mn ²⁺	Fe ²⁺ Fe ³⁺	Co ²⁺	Ni ²⁺	Cu ⁺ Cu ²⁺	Zn ²⁺				Se ²⁻		Br ⁻
Rb ⁺	Sr ²⁺									Ag ⁺	Cd ²⁺		Sn ²⁺		Te ²⁻		I ⁻
Cs ⁺	Ba ²⁺								Pt ²⁺	Au ⁺ Au ³⁺	Hg ₂ ²⁺ Hg ²⁺		Pb ²⁺	Bi ³⁺			

Valence Electrons

- When an atom undergoes a chemical reaction, only the outermost electrons are involved.
- These electrons are of the highest energy and are furthest away from the nucleus. These are the *valence electrons*.
- The valence electrons are the *s* and *p* electrons beyond the noble gas core.

Predicting Valence Electrons

- The Roman numeral in the American convention indicates the number of valence electrons.
 - Group IA elements have 1 valence electron
 - Group VA elements have 5 valence electrons
- When using the IUPAC designations for group numbers, the last digit indicates the number of valence electrons.
 - Group 14 elements have 4 valence electrons
 - Group 2 elements have 2 valence electrons

Electron Dot Formulas

- An electron dot formula of an element shows the symbol of the element surrounded by its valence electrons.

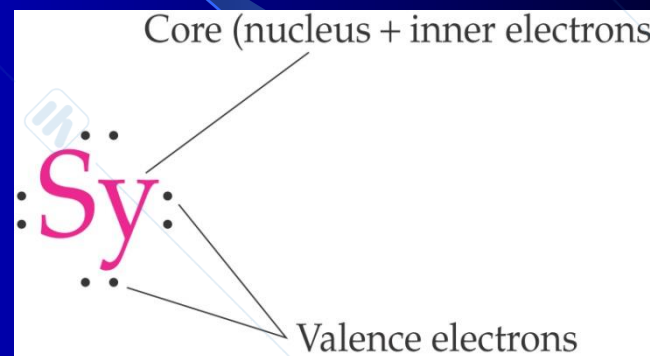

- We use one dot for each valence electron.
- Consider phosphorous, P, which has 5 valence electrons. Here is the method for writing the electron dot formula.

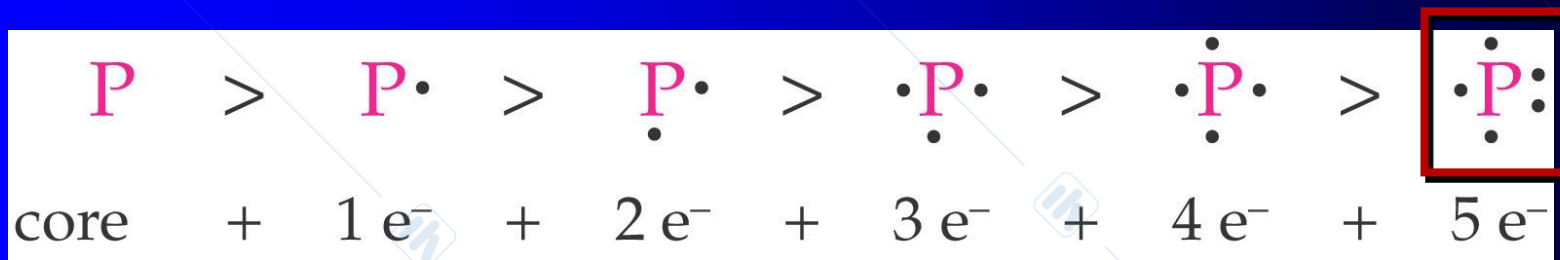

General Periodic Trends

- Atomic and ionic size
- Ionization energy
- Electron affinity

Higher effective nuclear charge.
Electrons held more tightly

Smaller orbitals.
Electrons held more
tightly. Atomic size increases

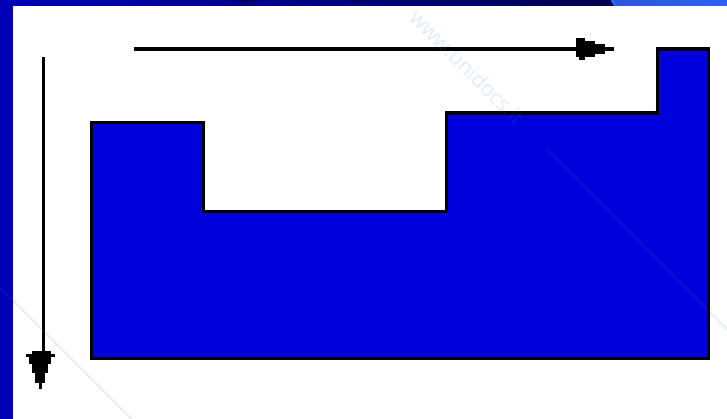

Atomic Size

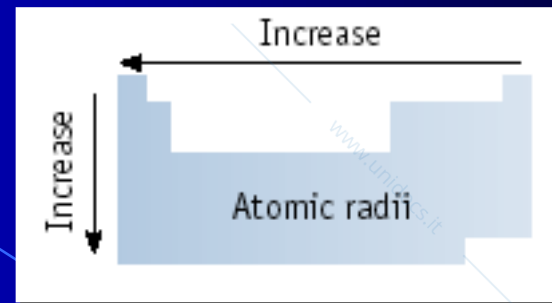

- Size goes **UP** on going down a group.
- Because electrons are added farther from the nucleus, there is less attraction.
- Size goes **DOWN** on going across a period.

Atomic Radii

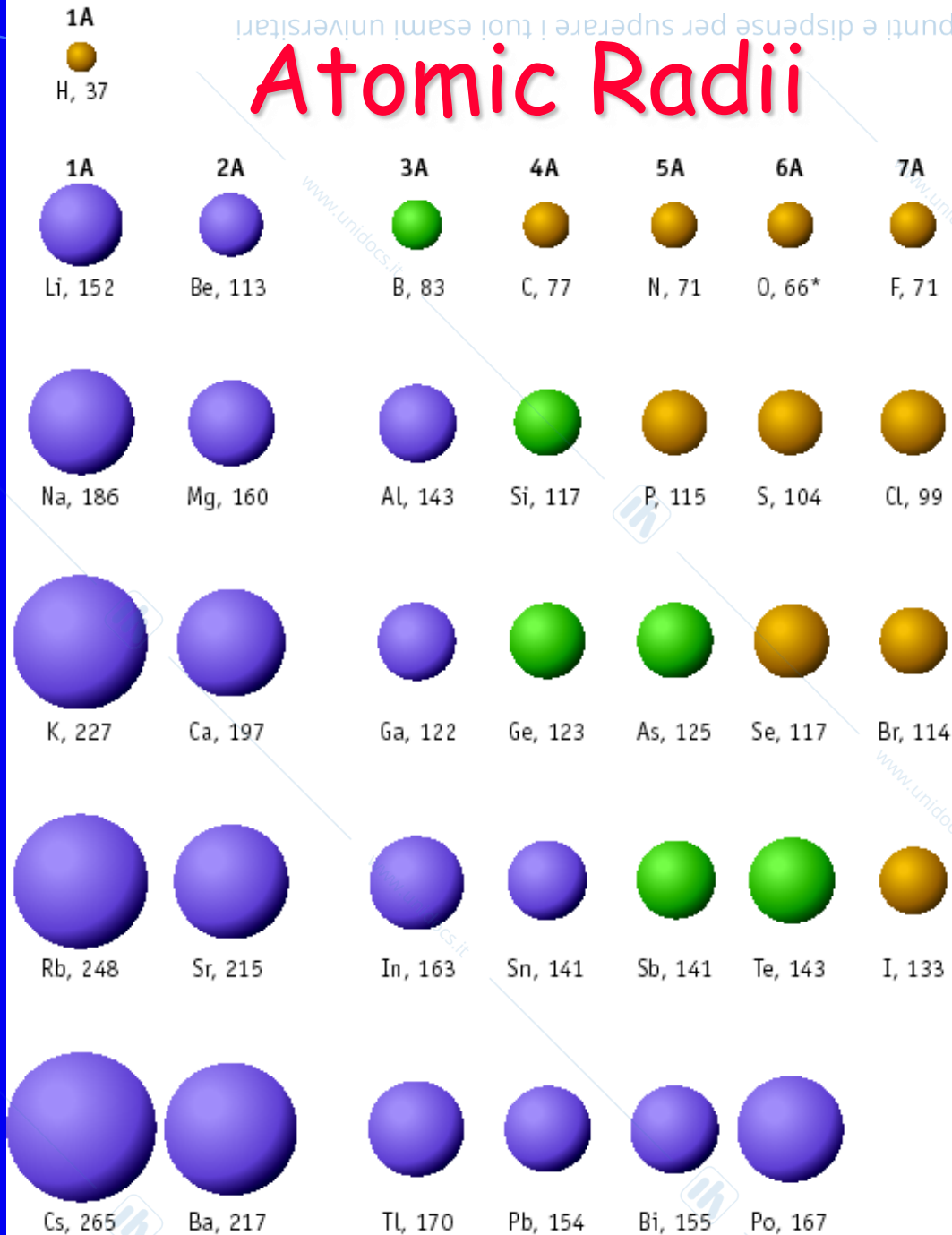

www.unidocs.it - Appunti e dispense per superare i tuoi esami universitari

www.unidocs.it - Appunti e dispense per superare i tuoi esami universitari

Chemical bonds

Law of Constant Composition (1799 Joseph Louis Proust)

- A given compound always contains the same proportion by mass of the elements of which it is composed.
 - ✓ A mixture can have variable composition but the composition of a compound is fixed
 - ✓ Does this give us a clue about the nature of matter?

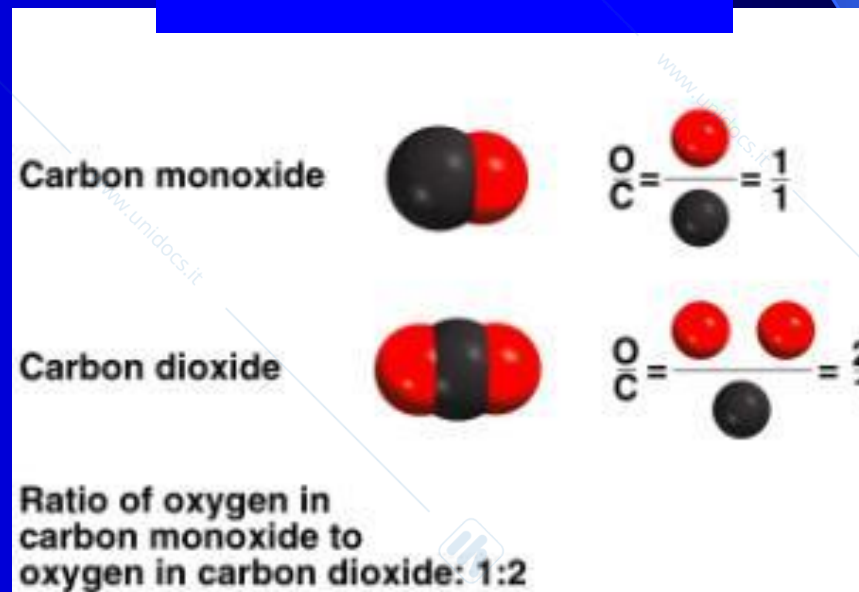

Formulas of Compounds

- A compound is represented by a chemical formula in which the number and kind of atoms present is shown by using the element symbols and subscripts.

Example: the simple sugar, glucose

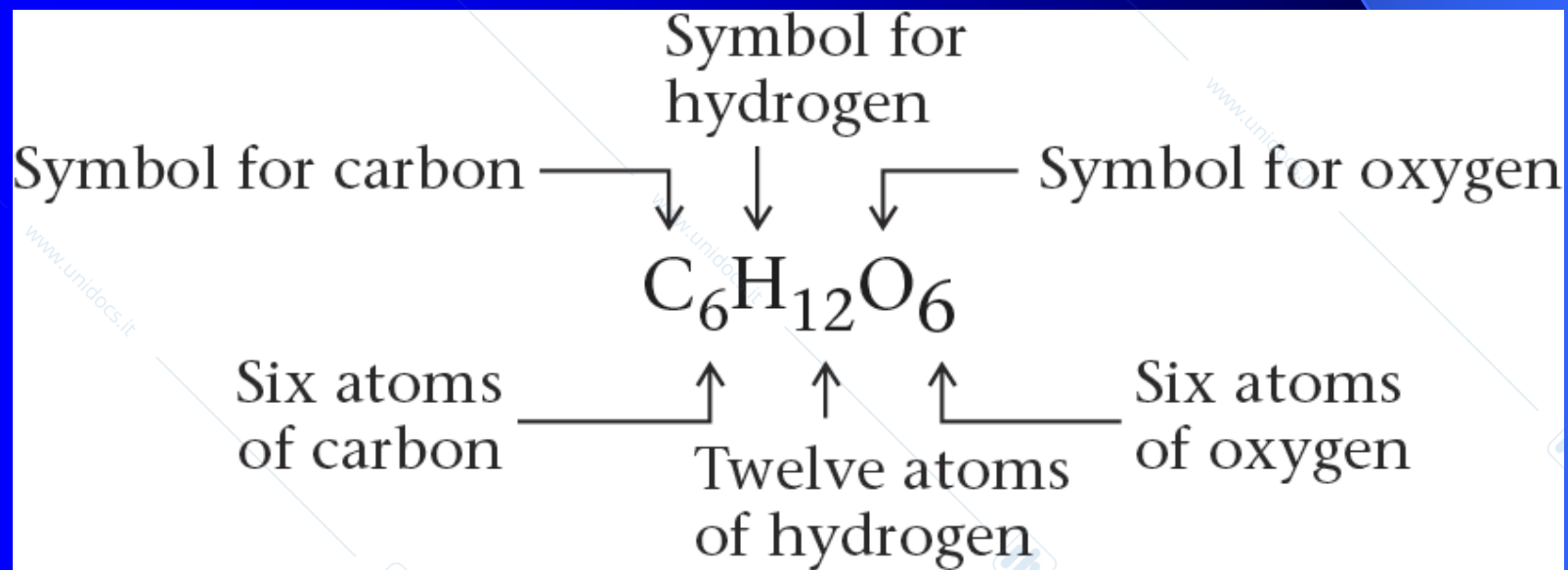

Formulas of Compounds

Tools for Writing Formulas

1. Each atom present is represented by its element symbol.
2. The number of each type of atom is indicated by a subscript written to the right of the element symbol.
3. When only one atom of a given type is present, the subscript 1 is not written.
4. Write a metallic element first if present (MgCl_2)
5. Write the central atom of a molecule first (PCl_5)
6. Write Carbon first and Hydrogen second for an organic molecule ($\text{C}_6\text{H}_{12}\text{O}_6$)

Why are electrons important?

- 1) Elements have different electron configurations
 - different electron configurations mean different levels of bonding

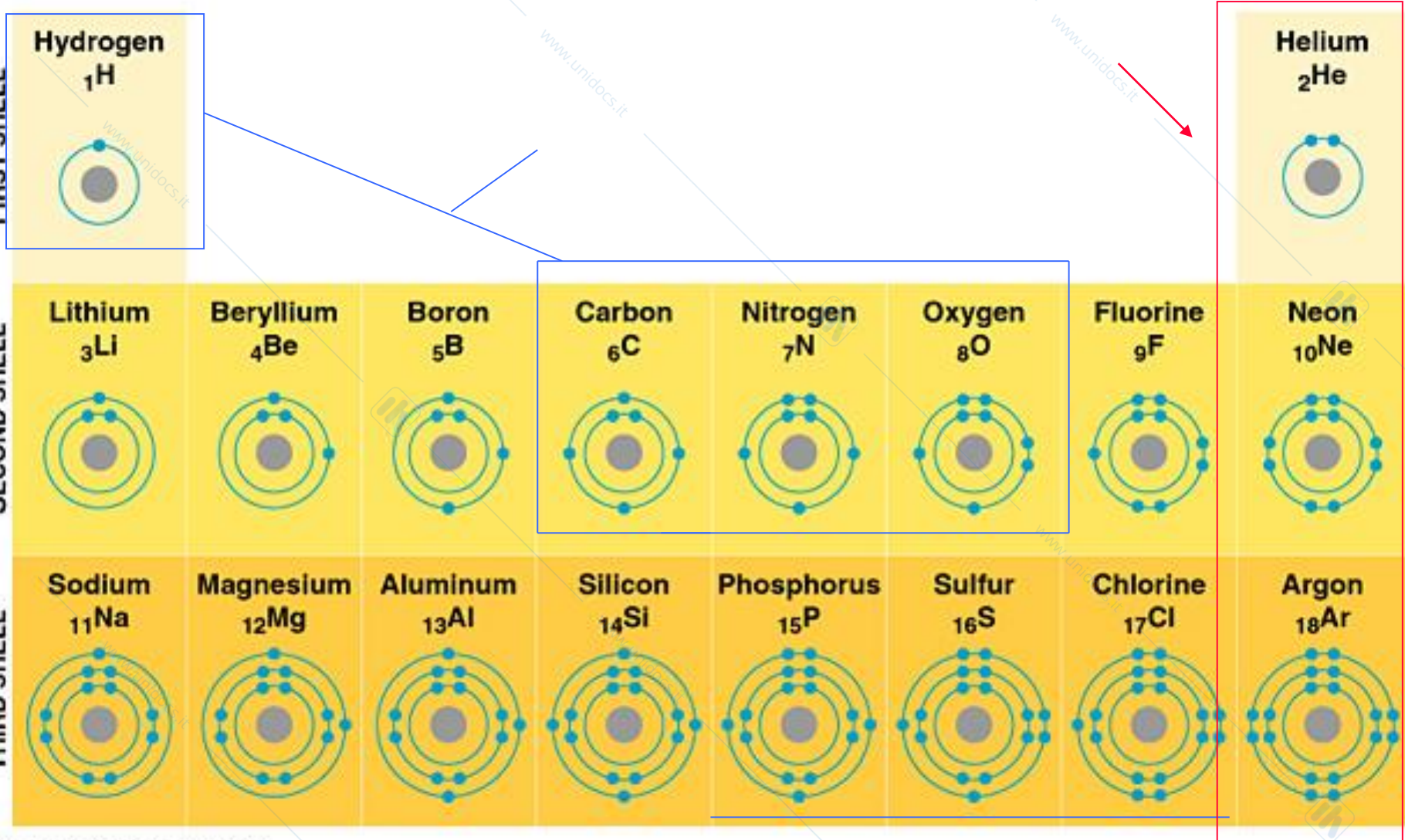

©1999 Addison Wesley Longman, Inc.

Chemical bonds

- What is a bond?

A bond is a link or force that binds two or a group of atoms together to form a compound.

The type of bonds found in biomolecules can be divided into two types ;

1-Covalent bonds.

2-Non-covalent bonds.(including , H bonds, ionic bonds, hydrophobic bonds, Van derWaals forces ,).

Driving force for bonds

- Chemical bonds make atoms more stable than they are if non-bonded
- Bond formation involves changes in the electrons on two atoms
 - Electron transfer
 - Electron sharing

Noble gases provide clues

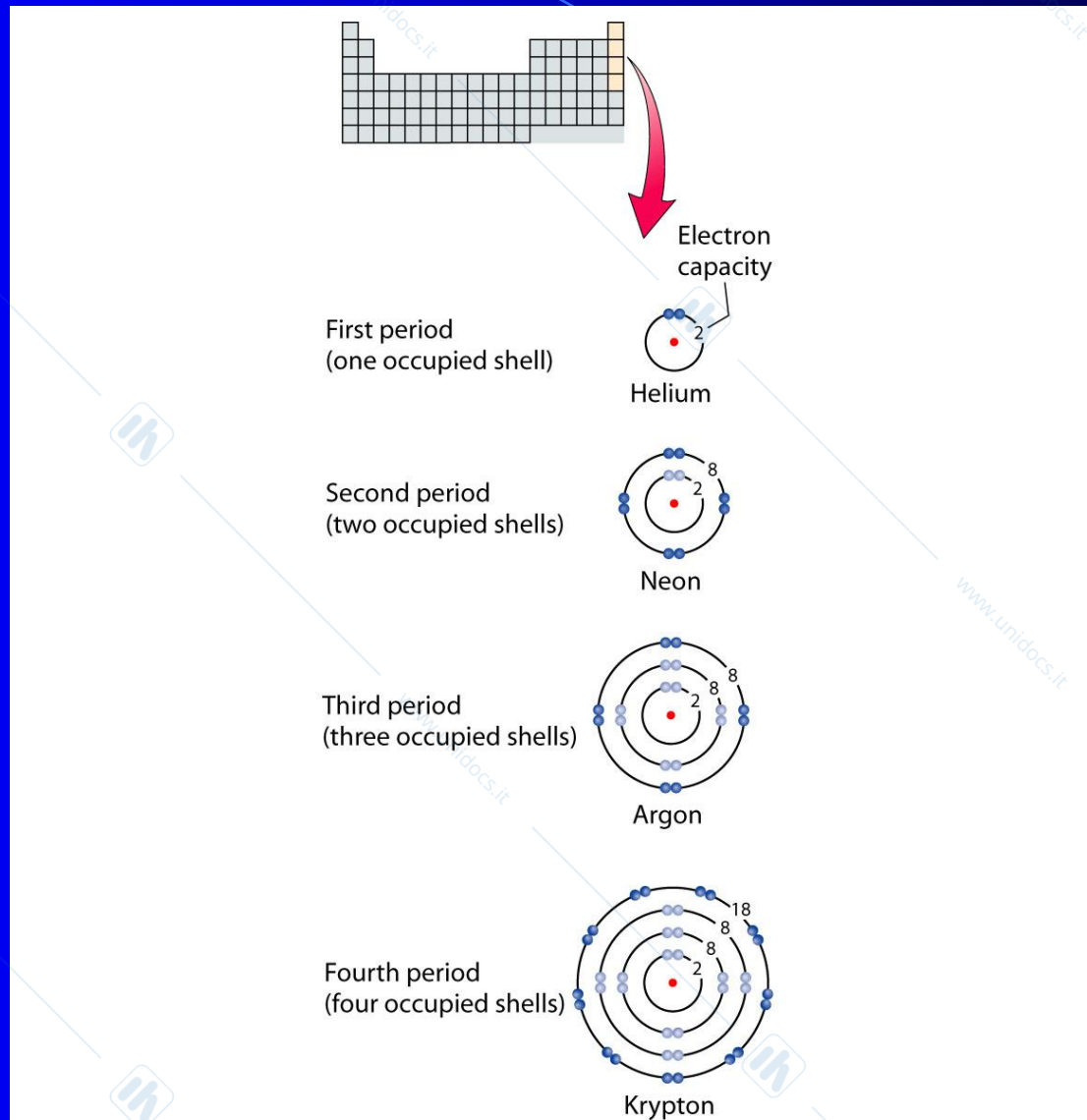

From *Conceptual Chemistry*, Second Edition by John Suchocki. Copyright © 2004 Benjamin Cummings, a division of Pearson Education.

Helium, neon and argon are atoms which do not react with other atoms.

We call them the Inert Gases (or Noble Gases) because of this.

Each of these gases has a full outer electron shell (orbit).

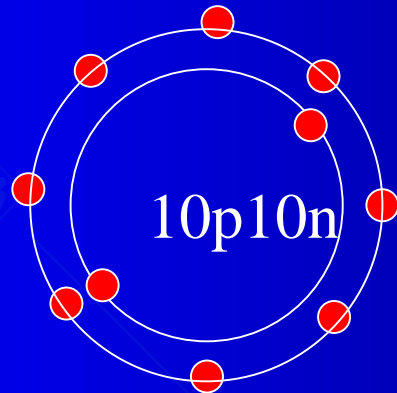
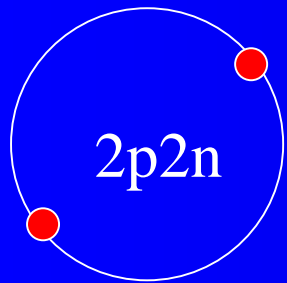

2,8

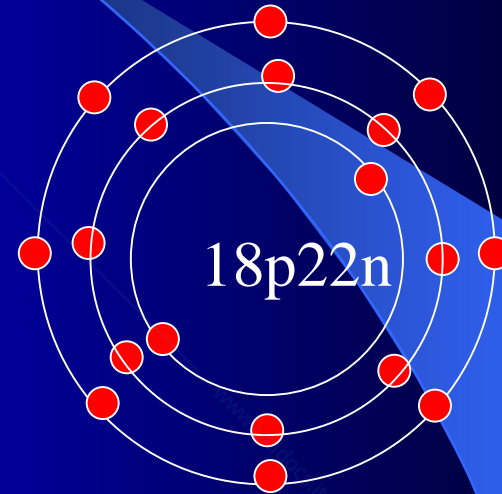

2,8,8

Chemical Bonds, Lewis Symbols, and the Octet Rule

The Octet Rule

- All noble gases except He has an s^2p^6 configuration.
- **Octet rule:** atoms tend to gain, lose, or share electrons until they are surrounded by 8 valence electrons (4 electron pairs).
- **Caution:** there are many exceptions to the octet rule.

The Octet Rule:

Happiness is a filled shell

- All elements strive to become a noble gas, at least as far as the electrons are concerned.
- Filling the outer shell – 8 electrons
 - Achieve this by adding electrons
 - Or taking them away

Filled shells by gain or loss of electrons

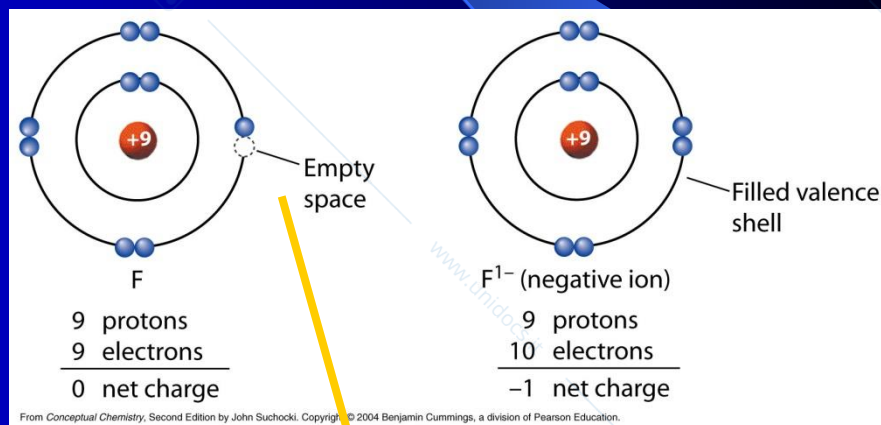
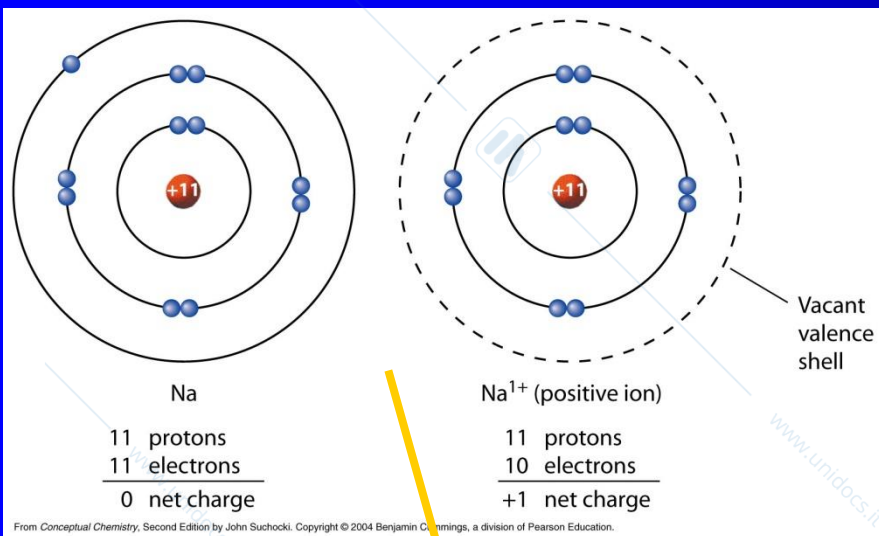

Lose electron –
inner shell full

Gain electron –
outer shell full

Electron Affinities

- Electron affinity is the opposite of ionization energy.
- Electron affinity: the energy change when a gaseous atom gains an electron to form a gaseous ion:



- Electron affinity can either be exothermic (as the above example) or endothermic:



Electron Affinity

A few elements **GAIN** electrons to form **anions**.

Electron affinity is the energy change when an electron is added:



Trends in Electron Affinity

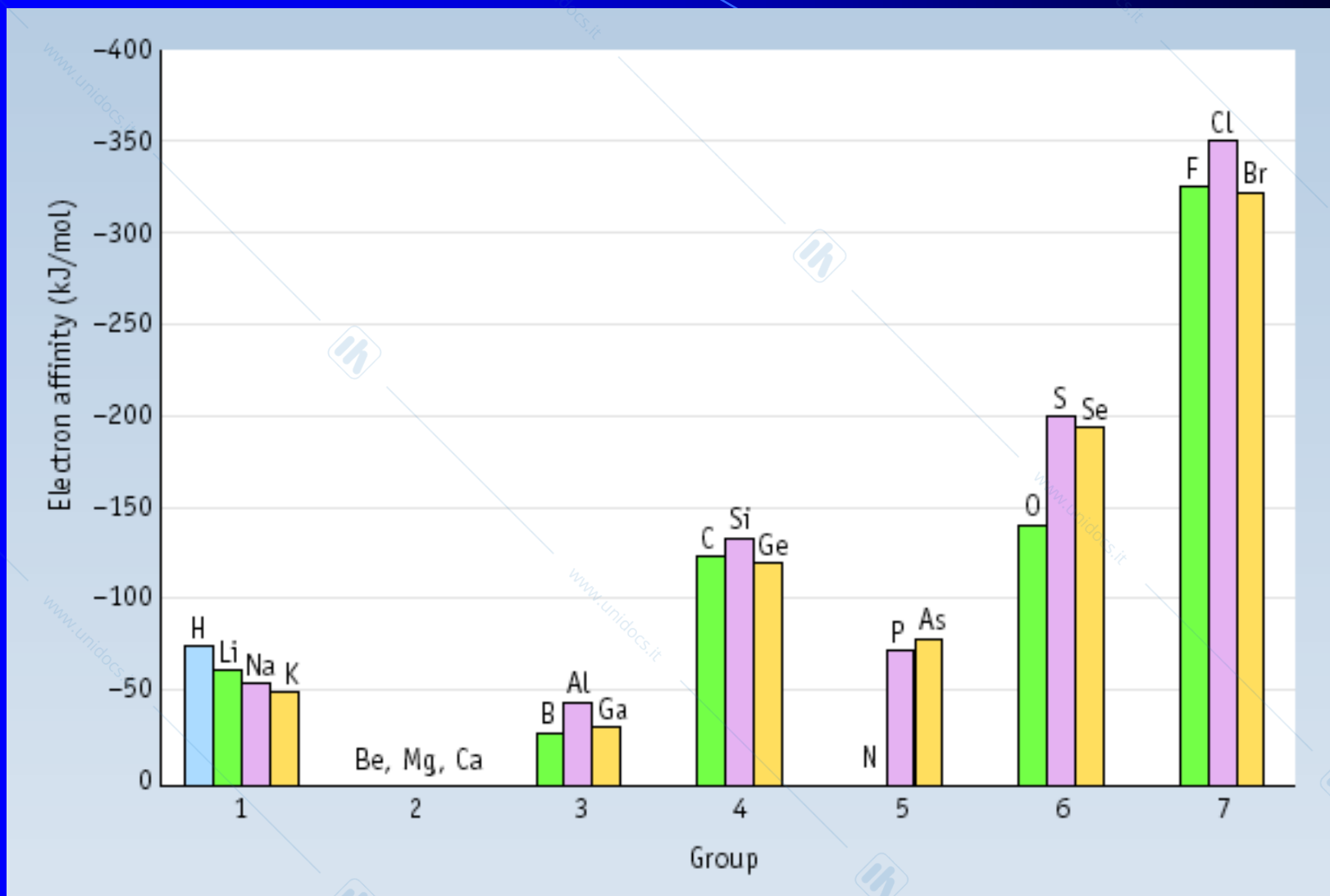

a

H											B	C	N	O	F	
2,1											2,0	2,5	3,0	3,5	4,0	
Li	Be											Al	Si	P	S	Cl
1,0	1,5											1,5	1,8	2,1	2,4	3,0
Na	Mg											Ga	Ge	As	Se	Br
1,0	1,2											1,7	1,9	2,1	2,1	2,8
K	Ca	Sc	Ti	V	Cr	Mn	Fe	Co	Ni	Cu	Zn	In	Sn	Sb	Te	I
0,9	1,0	1,3	1,4	1,5	1,6	1,6	1,7	1,7	1,8	1,8	1,6	1,6	1,8	1,9	2,1	2,5
Rb	Sr	Y	Zr	Nb	Mo	Tc	Ru	Rh	Pd	Ag	Cd	Tl	Pb	Bi	Po	At
0,9	1,0	1,2	1,3	1,5	1,6	1,7	1,8	1,8	1,8	1,6	1,6	1,6	1,7	1,8	1,9	2,1
Cs	Ba	La	Hf	Ta	W	Re	Os	Ir	Pt	Au	Hg	Pb	Bi	Po	At	
0,8	1,0	1,1	1,3	1,4	1,5	1,7	1,9	1,9	1,8	1,9	1,7	1,7	1,8	1,9	2,1	
Fr	Ra	Ac														
0,8	1,0	1,1														

b

H						
Li	Be	B	C	N	O	F
Na	Mg	Al	Si	P	S	Cl
K	Ca	Ga	Ge	As	Se	Br
Rb	Sr	In	Sn	Sb	Te	I
Cs	Ba	Tl	Pb	Bi	Po	At

Figura 3.11. (a) Valori di elettronegatività secondo Pauling; (b) periodicità dei valori di elettronegatività.

Ionization Energy

IE = energy required to remove an electron from an atom in the gas phase.

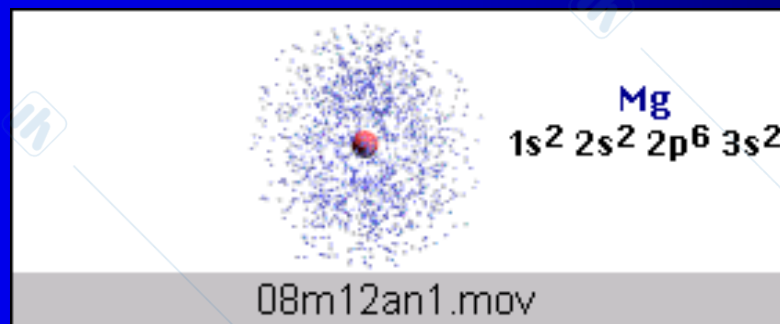

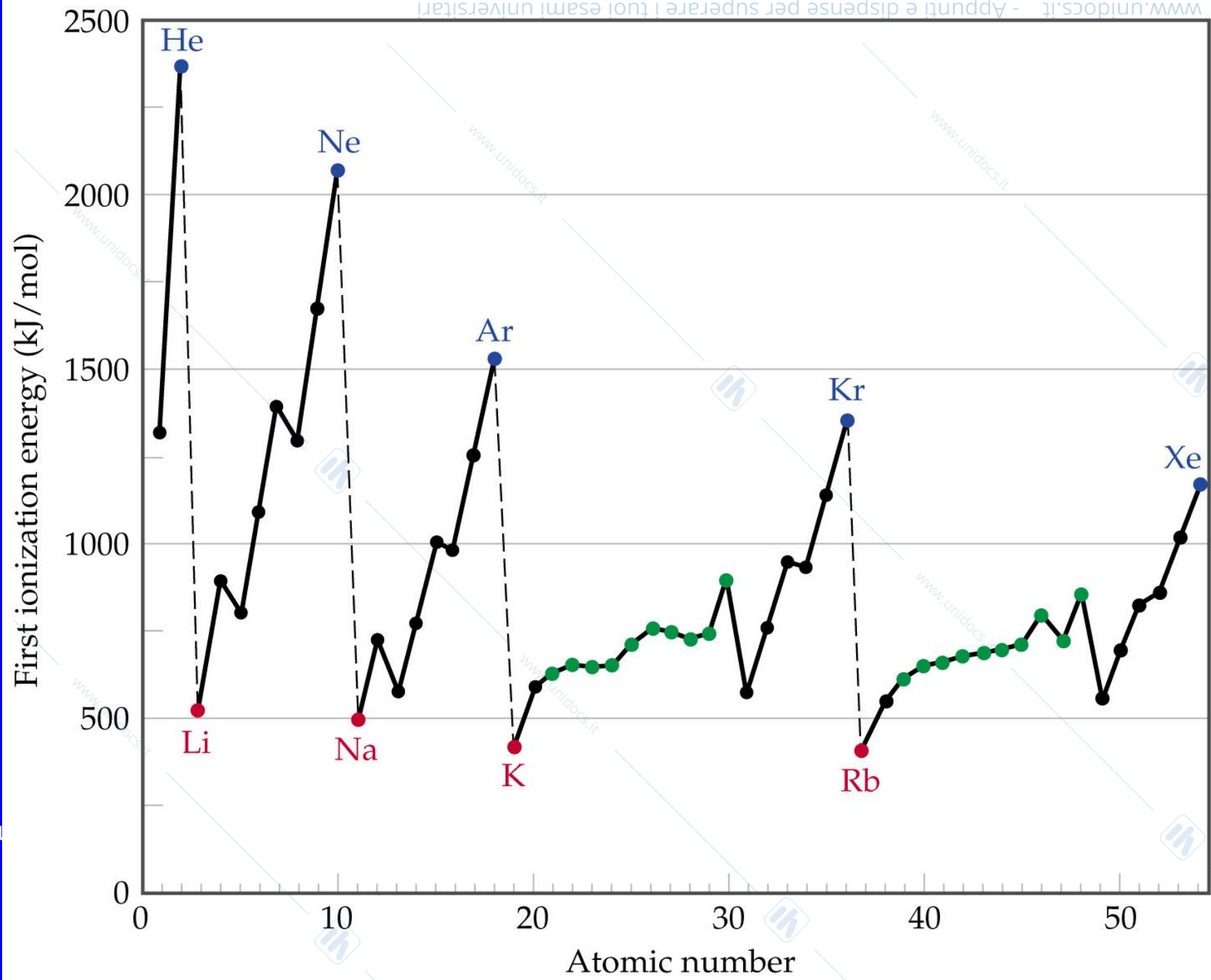

Figura

Removing the second electron requires more energy, and is called the second ionization energy.

Each successive ionization requires more energy, but it is not a steady increase.

Ionization Energy

Table 6.5

**Successive Ionization Energies
for the Period 2 Elements**

Element	Valence Electrons	Ionization Energy (kJ/mol)*								
		1 st	2 nd	3 rd	4 th	5 th	6 th	7 th	8 th	9 th
Li	1	520	7300							
Be	2	900	1760	14,850						
B	3	800	2430	3660	25,020					
C	4	1090	2350	4620	6220	37,830				
N	5	1400	2860	4580	7480	9440	53,270			
O	6	1310	3390	5300	7470	10,980	13,330	71,330		
F	7	1680	3370	6050	8410	11,020	15,160	17,870	92,040	
Ne	8	2080	3950	6120	9370	12,180	15,240	20,000	23,070	115,380

* mol is an abbreviation for mole, a quantity of matter.

Ionic Charge

- Recall, that atoms *lose or gain electrons* to form ions.
- The charge of an ion is related to the number of valence electrons on the atom.
- Group IA/1 metals lose their one valence electron to form 1+ ions.
 - $\text{Na} \rightarrow \text{Na}^+ + \text{e}^-$
- Metals lose their valence electrons to form ions.

Predicting Ionic Charge

- Group IA/1 metals form 1+ ions, group IIA/2 metals form 2+ ions, group IIIA/13 metals form 3+ ions, and group IVA/14 metals form 4+ ions.
- By losing their valence electrons, they achieve a noble gas configuration.
- Similarly, nonmetals can gain electrons to achieve a noble gas configuration.
- Group VA/15 elements form -3 ions, group VIA/16 elements form -2 ions, and group VIIA/17 elements form -1 ions.

- We can predict the charge on the ion of an element from its position on the periodic table.

1	2											13	14	15	16	17	18
IA	IIA											IIIA	IVA	VA	VIA	VIIA	VIIIA
1+														3-	2-	1-	
Li														N	O	F	
1+	2+	3	4	5	6	7	8	9	10	11	12	3+		3-	2-	1-	
Na	Mg	IIIB	IVB	VB	VIB	VIIB	VIII	VIII	VIII	IB	IIB	Al		P	S	Cl	
1+	2+														2-	1-	
K	Ca														Se	Br	
1+	2+												4+			1-	
Rb	Sr												Sn			I	
1+	2+												4+				
Cs	Ba												Pb				

Symbol $\begin{matrix} 1+ \text{ or } 1- \\ \text{H} \end{matrix}$

Ion Electron Configurations

- When we write the electron configuration of a positive ion, we remove one electron for each positive charge:

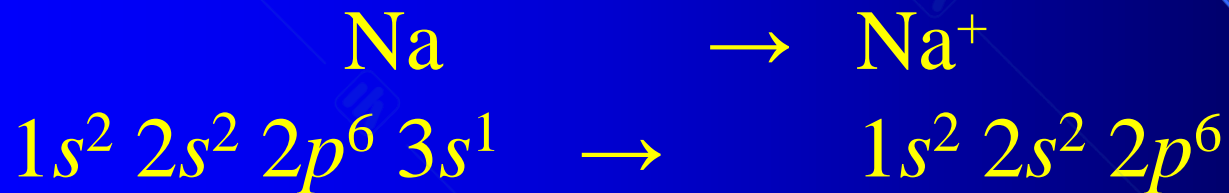

- When we write the electron configuration of a negative ion, we add one electron for each negative charge:

