

Enabling Technologies

Building Blocks for Optical Networks

Communication Network Design (2019)

Massimo Tornatore

Dept. of Electronics, Information and Bioengineering

Politecnico di Milano

Piazza Leonardo da Vinci 32 - 20133 Milan, Italy

massimo.tornatore@polimi.it

Most of the material is by courtesy of Prof. Biswanath Mukherjee @UCD

Enabling Technologies – Building Blocks

- ▷ Optical Fibers
- ▷ Optical Transmitters
- ▷ Optical Receivers
- ▷ Optical Filters
- ▷ Optical Amplifiers
- ▷ Switching Elements
- ▷ Wavelength Conversion
- ▷ Designing WDM Networks: System Considerations

Optical Components

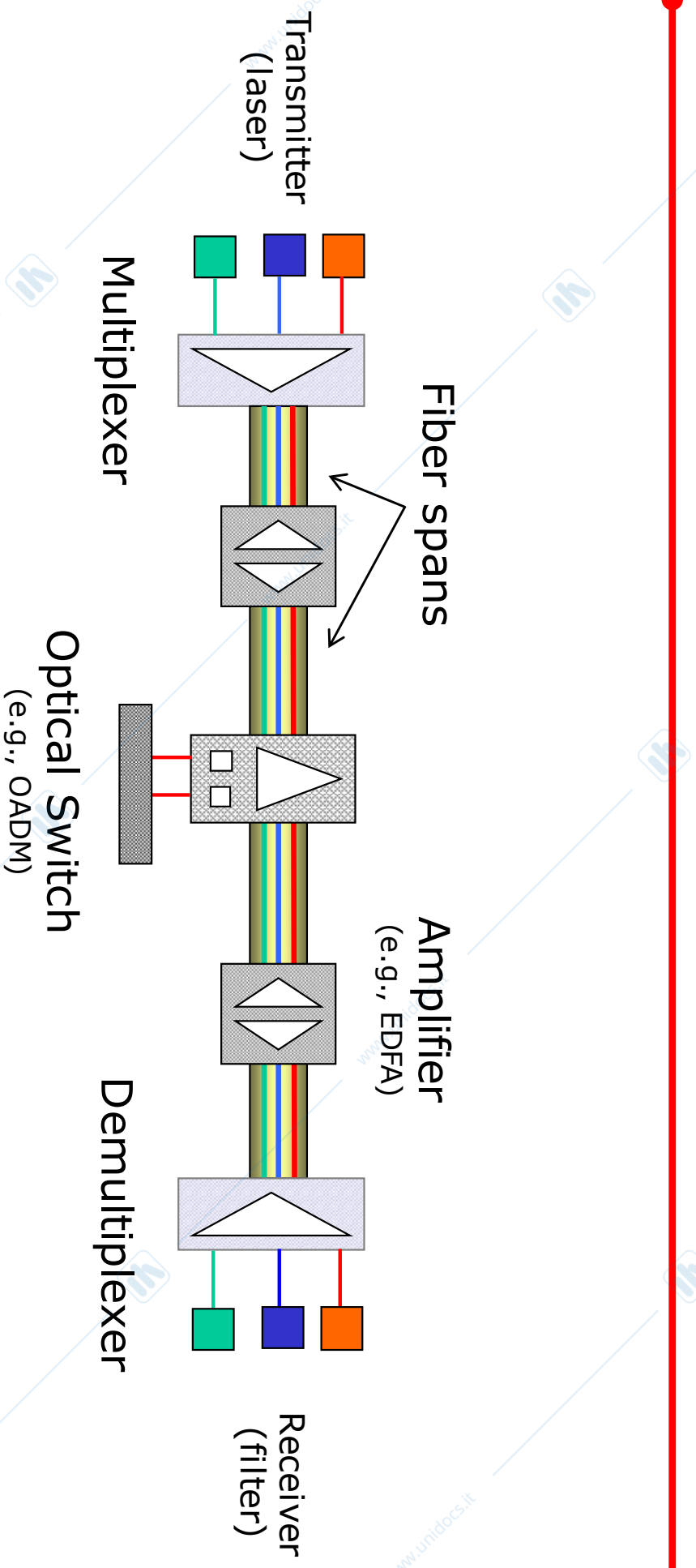

Enabling Technologies – Building Blocks

- ▷ **Optical Fibers**
- ▷ Optical Transmitters
- ▷ Optical Receivers
- ▷ Optical Filters
- ▷ Optical Amplifiers
- ▷ Switching Elements
- ▷ Wavelength Conversion
- ▷ Designing WDM Networks: System Considerations

Optical fiber

Structure

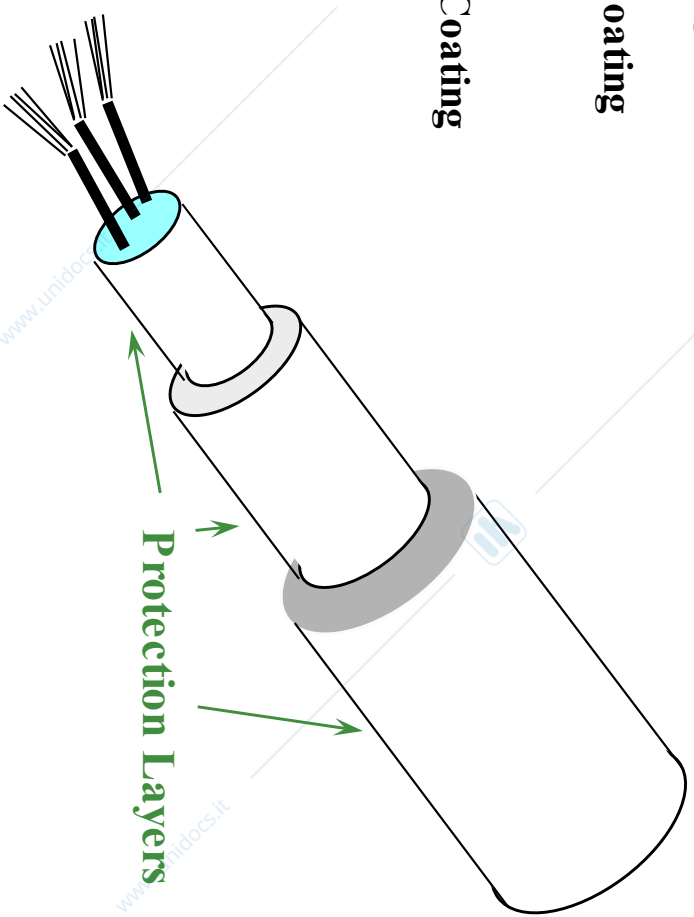
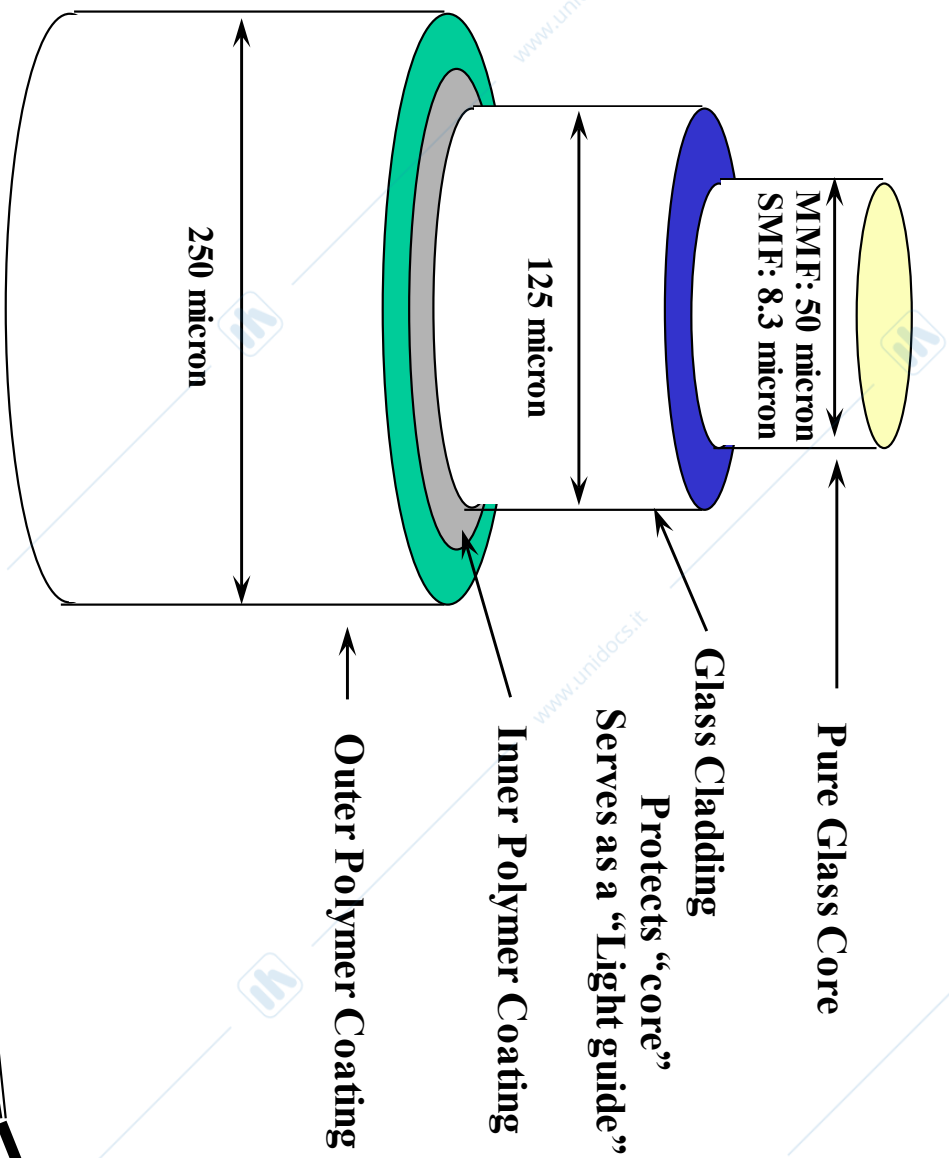

Source: John Strand, 2002

Single Fiber

All-Wave Fiber... low-loss region + WDM

(a) All-wave fiber (true wave, Leaf, etc.)

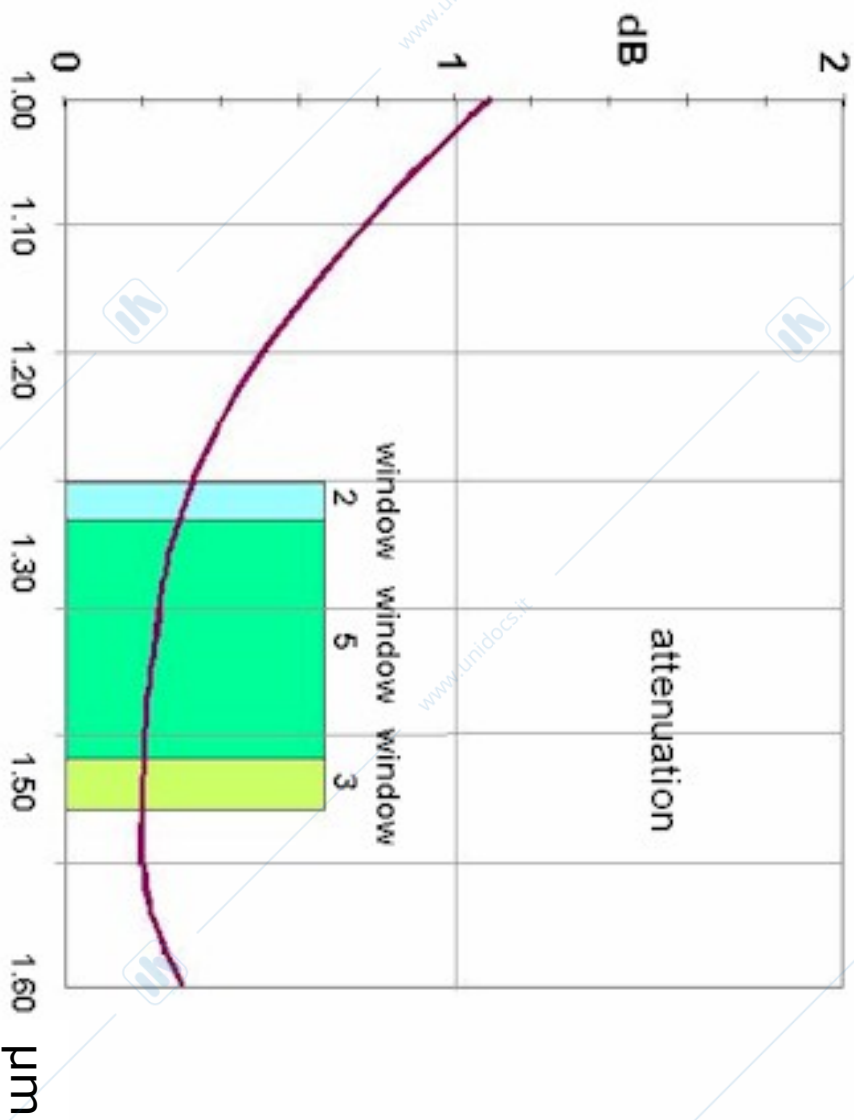

(b) Traditional fiber

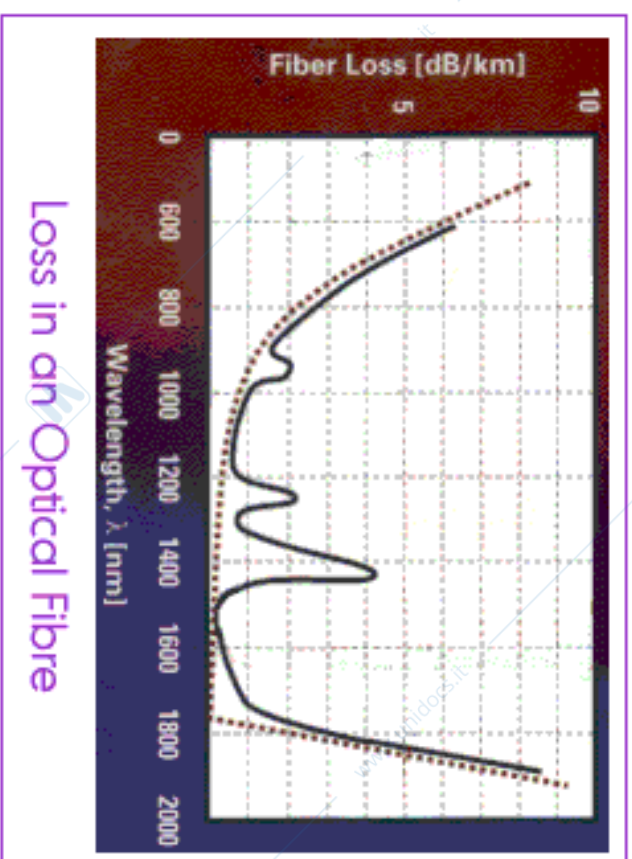

- Removal of water molecule absorption peak.
- All-wave fiber: 100 nm more b/w (1350 to 1450 nm).
- All-wave fiber allows 120 or more channels.

WDM = wavelength-division multiplexing
(wavelength = channel)

O-,E-,S-,C-,L-,U-Band

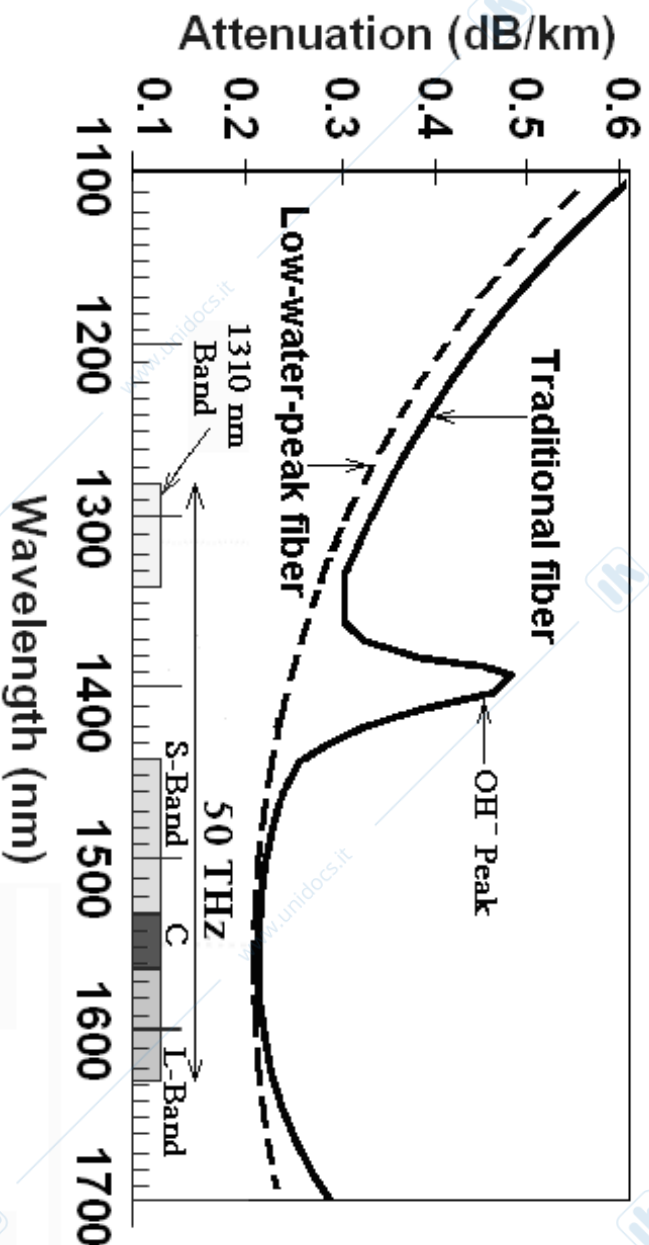

Band	Name	Wavel. range (nm)	Description
O-band	Original	1260-1360	Original band, PON upstream
E-band	Extended	1360-1460	Water peak band
S-band	Short	1460-1530	PON downstream
C-band	Conventional	1530-1565	Lowest attenuation, original DWDM band, compatible with fiber amplifiers, CATV
L-band	Long	1565-1625	Low attenuation, expanded DWDM band
U-band	Ultra-long	1625-1675	Ultra-long wavelength

1.3. Consider two regions, 1200-1400 nm and 1450-1650 nm, in a fiber low-loss spectrum. Calculate the actual bandwidth provided by each region. (Hint: Use the identity $f = v/\lambda$ where $v = 2.0 \times 10^8$ m/s. Note that velocity of light in vacuum is approx. 3.0×10^8 m/s, and the velocity of signals in fiber is approx. two-thirds of this value.)

Total Internal Reflection within a Fiber

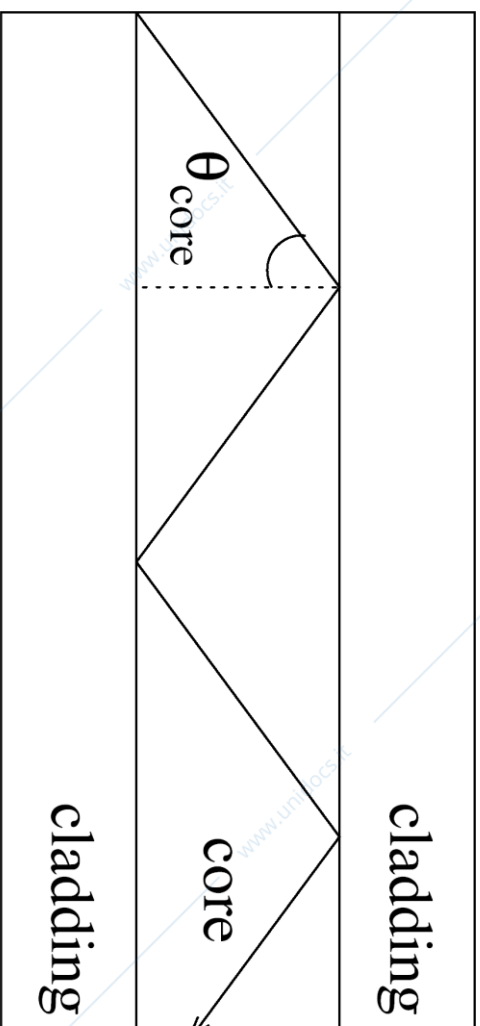

- ▷ *refractive index*: $n_{\text{mat}} = c/c_{\text{mat}}$ ($n_{\text{air}}=1$)
where c = velocity of light in vacuum = 3×10^8 m/s
- ▷ *critical angle*
 $c_{\text{mat}} \cong 2 \times 10^8$ m/s $\rightarrow n_{\text{fiber}}=1.5$
- ▷ *step-index fiber*

Snell's Law

- Snell's law describes the relationship between
 - the angle of incidence (θ_1)
 - the angle refraction (θ_2)when referring to light passing through a boundary between two different transparent media (such as water and glass)
- Definition: *the ratio of the sines of the angles of incidence and refraction is equivalent to the reciprocal of the ratio of the indices of refraction*

$$\frac{n_1}{n_2} = \frac{\sin \theta_2}{\sin \theta_1}$$

$$n_1 \sin \theta_1 = n_2 \sin \theta_2$$

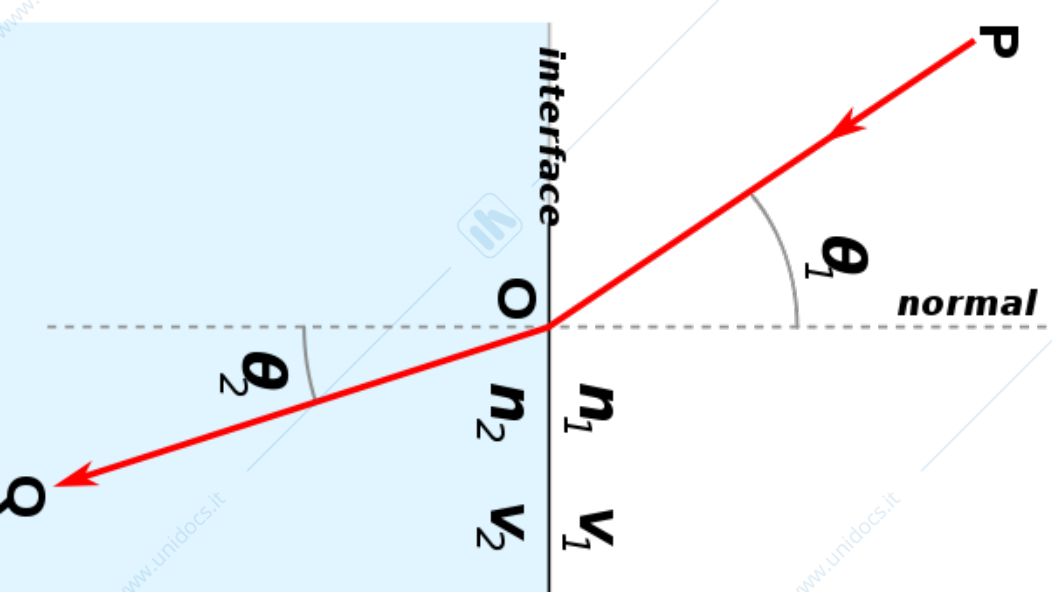

Total reflection

Law of Refraction (Snell's Law)

$$n_1 \sin \theta_1 = n_2 \sin \theta_2$$

Total Internal Reflection (Critical Angle)

$$\theta_c = \sin^{-1} \left(\frac{n_1}{n_2} \right) \quad ; \quad n_2 > n_1$$

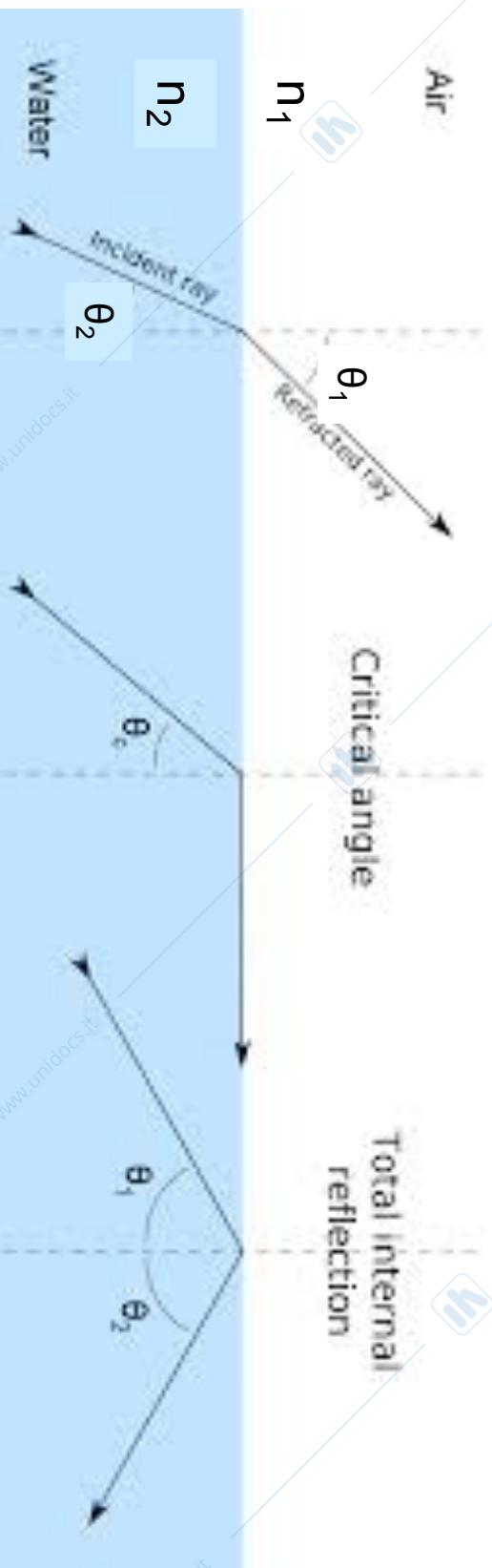

So, we want to avoid refraction...

If $\theta_2 > \theta_c$

Otherwise the light will be refracted and the associated energy will be lost.

$$\begin{cases} n_0 \sin \theta_0 = n_1 \sin \theta_1 \\ \theta_1 = 90 - \theta_2 \\ n_1 \sin \theta_2 = n_2 \sin \theta_3 \end{cases}$$

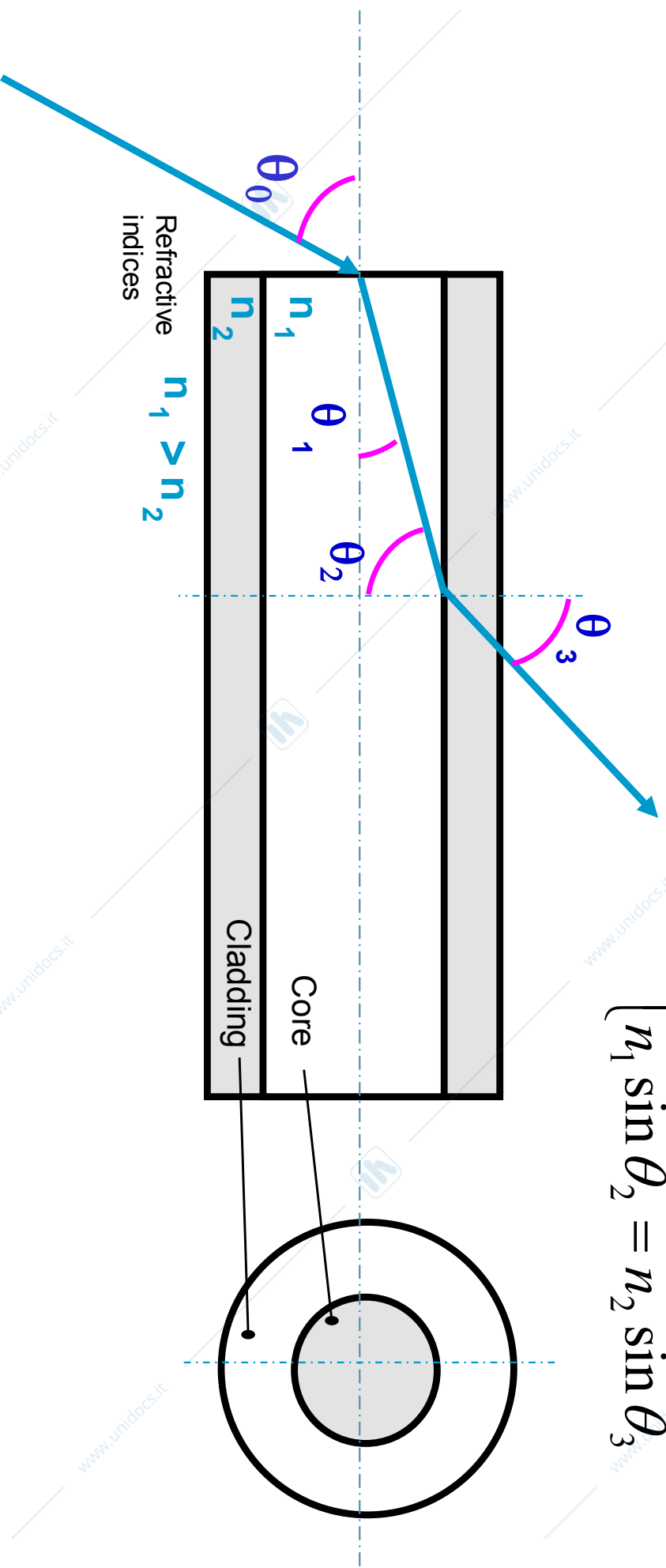

The «Critical Angle»

$$\begin{cases} n_0 \sin \theta_0 = n_1 \sin \theta_1 \\ \theta_1 = 90^\circ - \theta_2 \\ n_1 \sin \theta_2 = n_2 \sin \theta_3 \end{cases}$$

→ θ_c is the angle for which $\theta_3 = 90^\circ$

→ $\theta_c = \arcsin \left(\frac{n_{clad}}{n_{core}} \right)$
(Eqn 2.1)

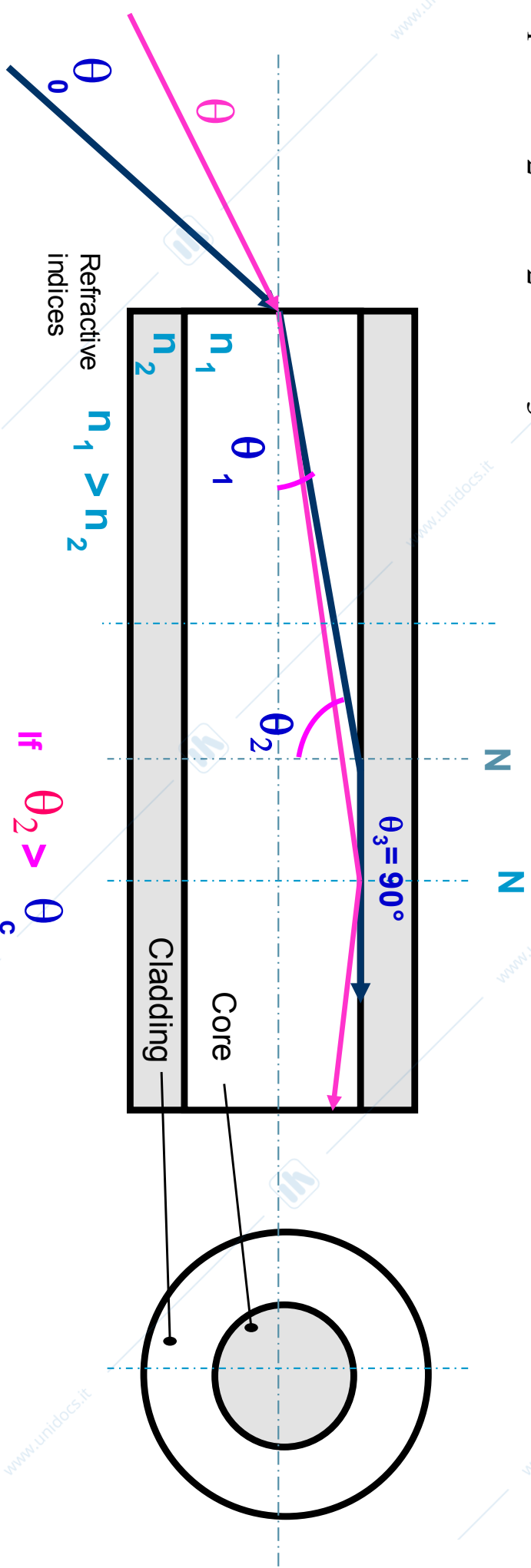

Then the mode will be reflected within the core and it will propagate along the fiber (total internal reflection).

Numerical Aperture of a Fiber

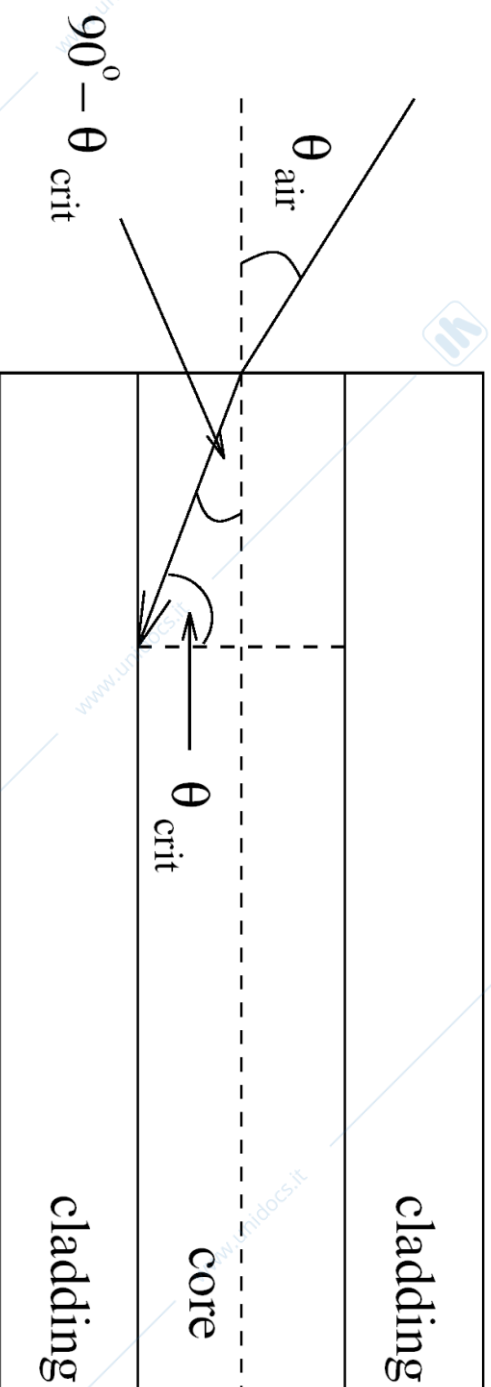

NB: The incoming light should be at an angle such that the refraction at the air-core boundary results in the transmitted light being at an angle for which total internal reflection can take place

$$\begin{aligned} n_{\text{air}} \sin \theta_{\text{air}} &= n_{\text{core}} \sin(90^\circ - \theta_{\text{crit}}) \\ &= n_{\text{core}} \sqrt{1 - \sin^2 \theta_{\text{crit}}} \end{aligned} \quad (2.2)$$

From Eqn. (2.1), since $\sin \theta_{\text{crit}} = n_{\text{clad}}/n_{\text{core}}$, we can rewrite Eqn. (2.2) as:

$$\begin{aligned} n_{\text{air}} \sin \theta_{\text{air}} &= \sqrt{n_{\text{core}}^2 - n_{\text{clad}}^2} \\ NA &= \sqrt{n_{\text{core}}^2 - n_{\text{clad}}^2} \end{aligned} \quad (2.3)$$

Profile of refractive index

- Graded-index fibers
 - Reduce the minimum θ_c required for internal reflection
 - Reduce intermodal dispersion

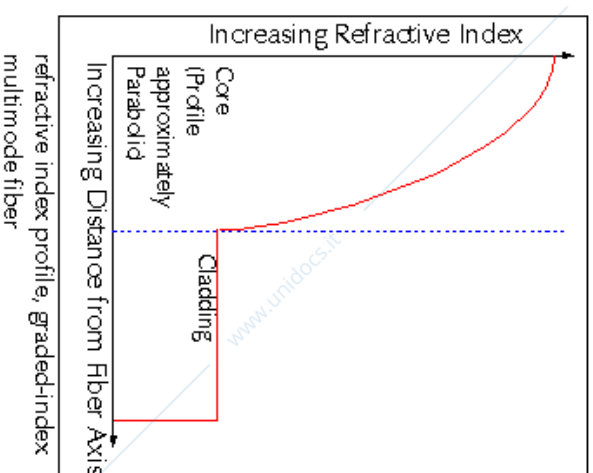

- Step-index fibers

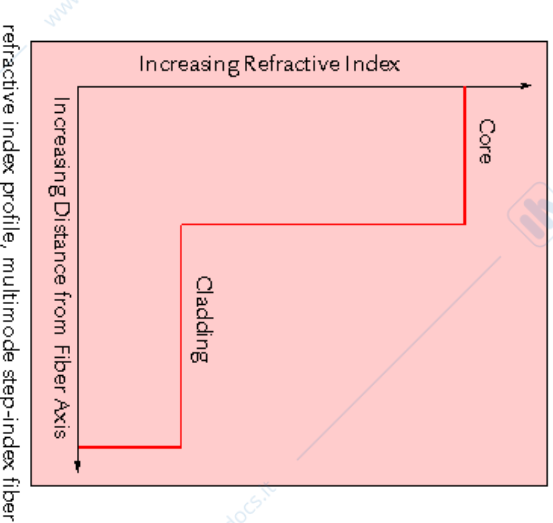

Graded-Index Fiber

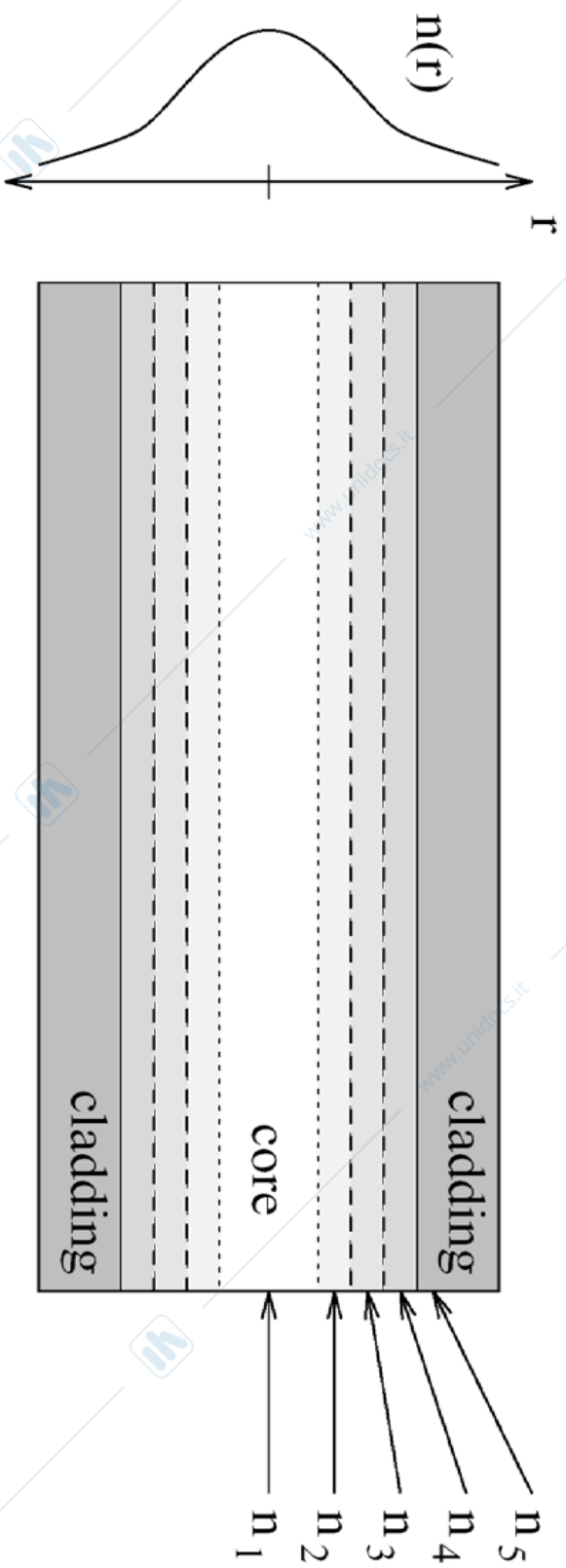

What is a propagation mode?

- There are different ways to model how a wave can propagate in a fiber
- The current model of optical fiber signal propagation is based on the electromagnetic field propagation modes (solutions of *Maxwell equations* for cylindrical media): modes are solutions of these equations.
- A large core diameter (25-100 μm) allows several modes (transversal field configurations) to be excited: modal dispersion
- A core with a small diameter behaves as a spatial optical filter (order of magnitude of the wavelength of 4-5 μm) and allows only the fundamental mode to propagate

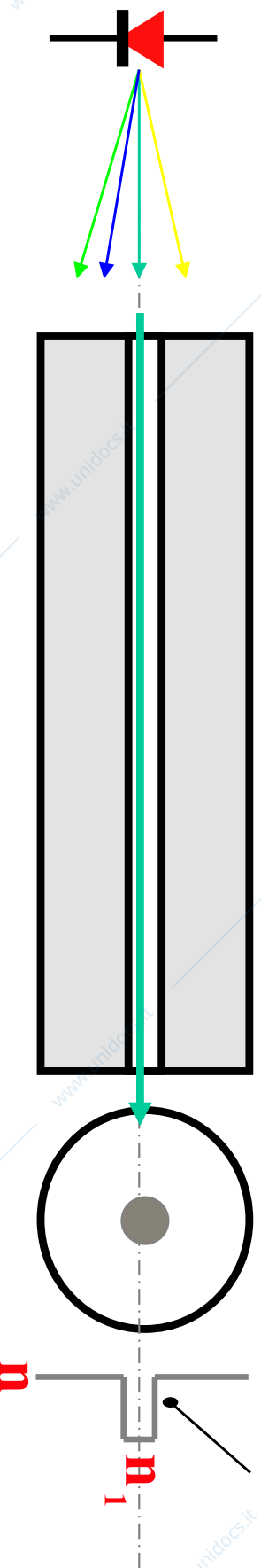
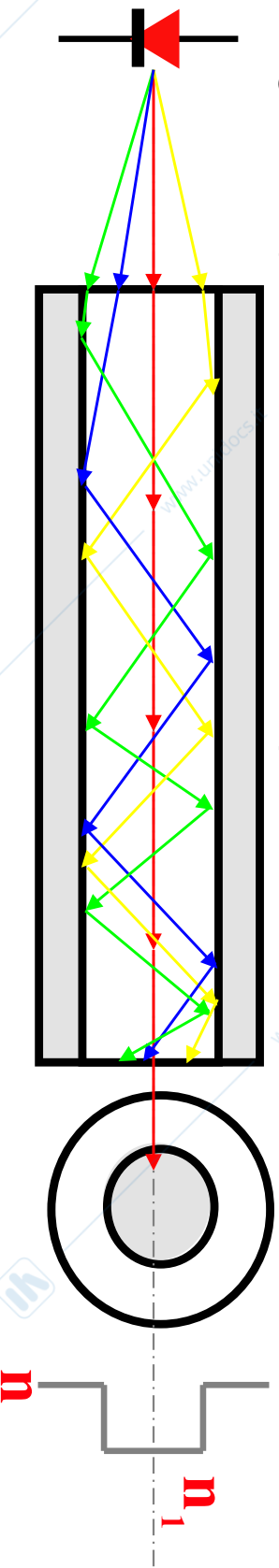

Nr of modes propagating in a fiber

The number of modes supported by a multimode optical fiber is related to the normalized frequency V which is defined as:

$$V = k_0 a \sqrt{n_{\text{core}}^2 - n_{\text{clad}}^2} \quad (2.4)$$

where $k_0 = 2\pi/\lambda$, a is the radius of the core, and λ is the wavelength of the propagating light in vacuum. In multimode fiber, the number of modes, m , is given approximately by:

$$m \approx \frac{1}{2} V^2. \quad (2.5)$$

Multimode and Single-Mode Optical Fibers

Optical Fibers

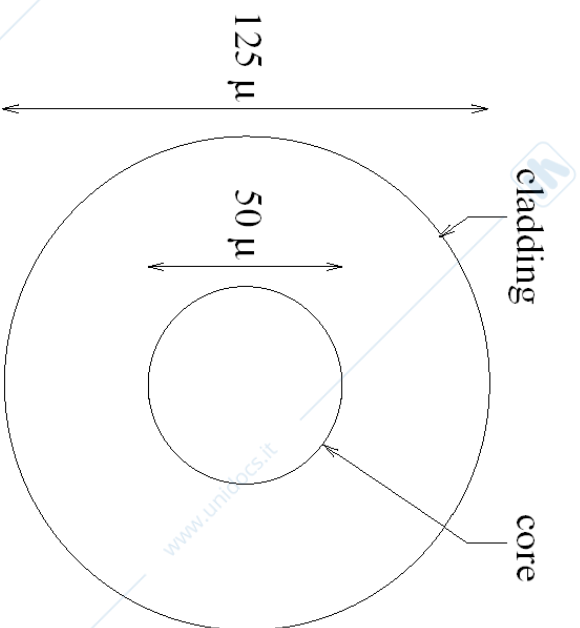

(a) Multimode Optical Fiber

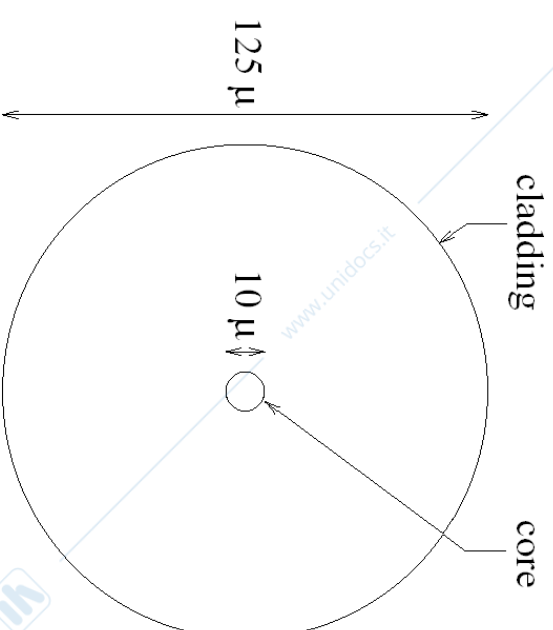

(b) Single-Mode Optical Fiber

PROs: LED

**CONs: intermodal dispersion
(limited by graded-index fibers)**

PROs: longer distances

CONs: requires LASER

We've seen how a fiber accommodates an optical signal, what happens to the signal during the

propagation:

- 1) attenuation**
- 2) dispersion**
- 3) non linearities**

Attenuation in Fiber

▷ Power of the optical pulse at distance L km from the transmitter:

$$P(L) = 10^{-AL/10} P(0)$$

where $P(0)$ = optical power at the transmitter, and

A = attenuation constant of the fiber (in dB/km) = approx. 0.2 dB/km at 1550 nm

▷ Maximum distance between transmitter and receiver (or maximum distance between amplifiers):

$$L_{\max} = \frac{10}{A} \log_{10} \frac{P(0)}{P_r}$$

where P_r = receiver sensitivity

Dispersion in Fiber

▷ **Dispersion is the widening of a pulse duration**

▷ **1. Intermodal dispersion:** different velocity for different modes

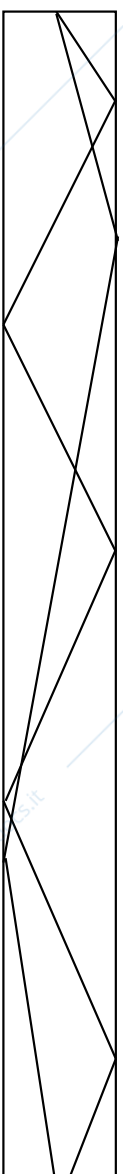

▷ **2. Chromatic dispersion:** index of refraction changes with wavelength

▷ **Material dispersion** (see next slide)

▷ **Waveguide dispersion:** velocity for different wavelengths depends to waveguide characteristics (e.g., shape of core/cladding)

▷ **Profile dispersion:** different effect of the index profile in graded-index fiber

▷ **3. Polarization mode dispersion:** different velocity for different modes

Chromatic dispersion

Material dispersion

- Spectral components of the signal travel at different speeds
- Shorter wavelengths propagate faster than the longer
- To achieve BER < 10^{-12} the total dispersion should be less than 1/10 of the bit duration (e.g. 10 ps @ 10 Gbit/s)

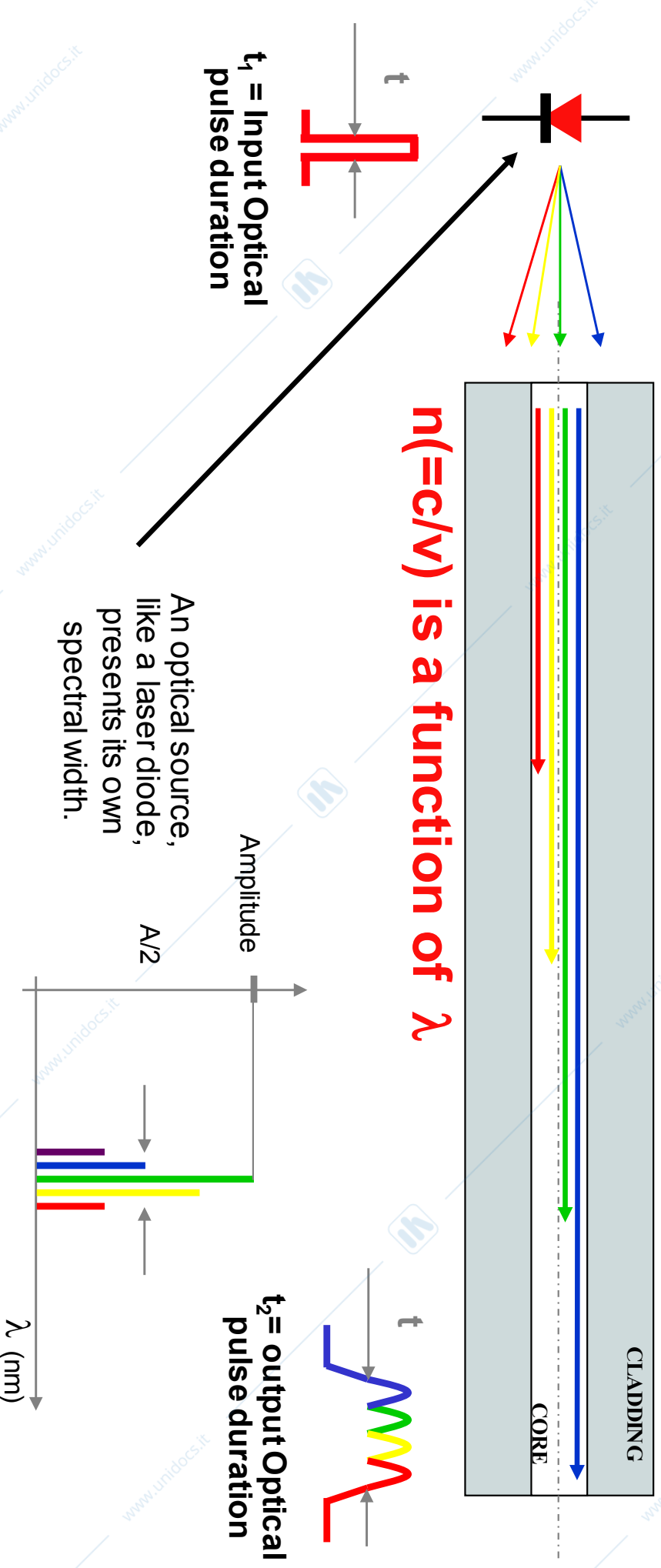

Polarization Mode Dispersion (PMD)

- Intrinsic Causes
 - Ellipticity of the core
 - Asymmetrical stress during the fiber manufacture ...
- Extrinsic Causes
 - Torsion of the fiber
 - Temperature variation
 - Thermal gradients ...

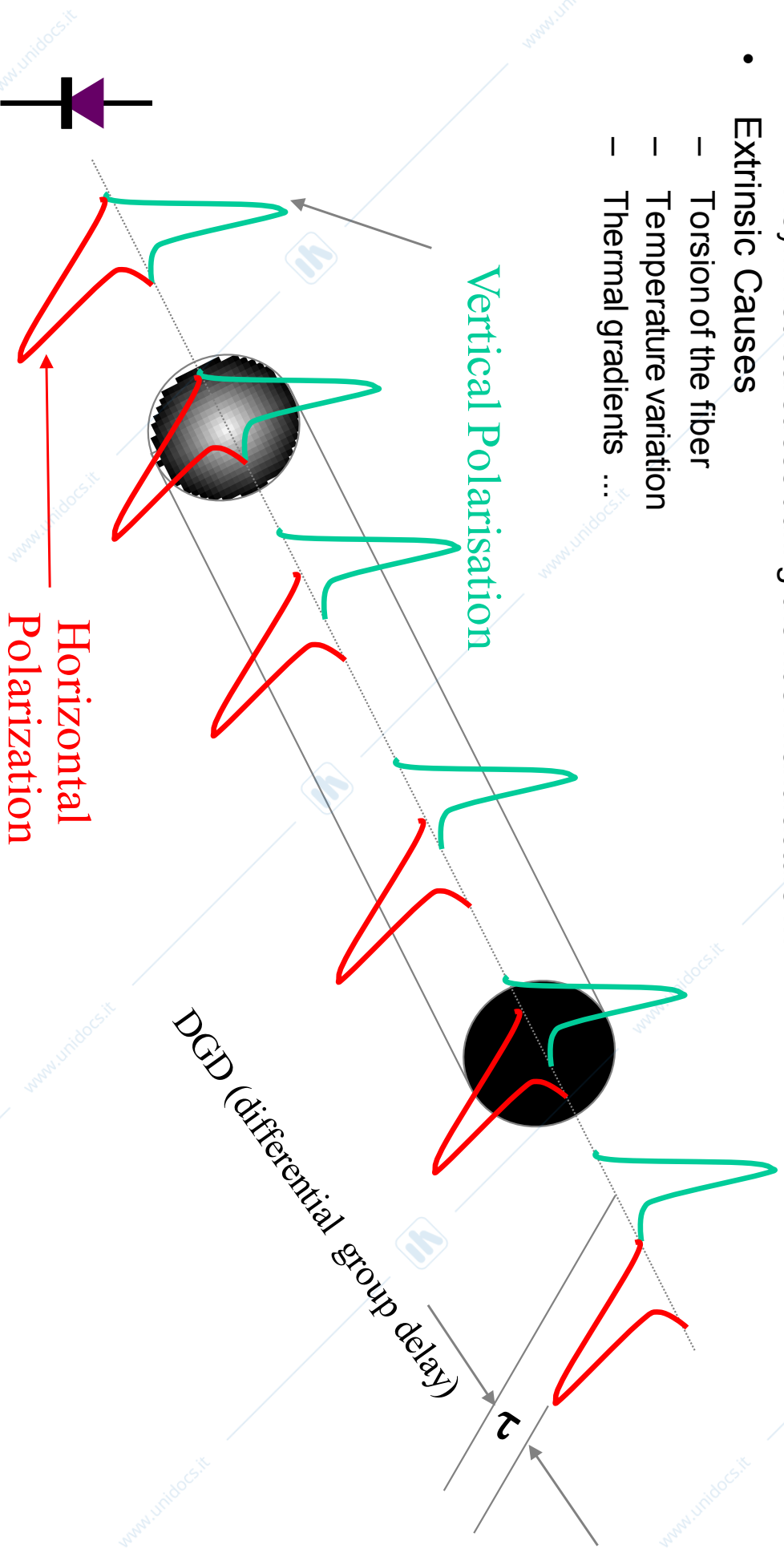

Different fiber types according to dispersion management

1. Dispersion unshifted

2. With Dispersion shifting:

- Zero dispersion fiber at a certain wavelength
- Waveguide dispersion cancels material dispersion
- @ 1300 nm, material dispersion is near zero for SMF
- Dispersion-compensated fiber (DCF)
 - typically, a piece of fiber with opposite dispersion characteristics is added
- Non-zero dispersion-shifted fiber (NZDSF)

Nonlinearities in Fiber

- ▷ May lead to **attenuation, distortion, and cross-channel interference**
- ▷ They constrain the **channel spacing, power per channel, and channel bit rate.**
- ▷ **Four Types of Nonlinearities**
 - **Nonlinear Refraction**: $n=f(I)$; received signal phase depends on 1) transmitted signal phase, 2) length of fiber, 3) signal power, 4) carrier wavelength
 - Self-phase modulation: result from the intensity of the same wavelength
 - $\varphi = n_2 k_0 L |E|^2$ (phase shift)
 - Cross-phase modulation: results from the intensity of other wavelengths

Nonlinearities in Fiber

- **Stimulated Raman Scattering (SRS)**
 - Interaction between light and molecular vibrations
 - Light incident on molecules creates scattered light at a longer wavelength
 - Poses a limit of input power
- **Stimulated Brillouin Scattering (SBS)**
 - Similar to SRS, frequency shift caused by acoustic waves
 - Intensity of scattered light is much greater than in SRS, but frequency range of SBS (10 GHz) is much lower than that of SRS
 - To avoid SBS, ensure that input power must stay below a given threshold

Non linearities in fiber

→ Four-Wave Mixing (FWM)

- Between 2 waves: $f_1, f_2 \rightarrow 2f_1 - f_2, 2f_2 - f_1$, which can overlap with other wavelengths
- Among 3 waves: $f_1, f_2, f_3 \rightarrow \pm f_1 \pm f_2 \pm f_3$
- Effect of FWM can be reduced by using unequally-spaced channels

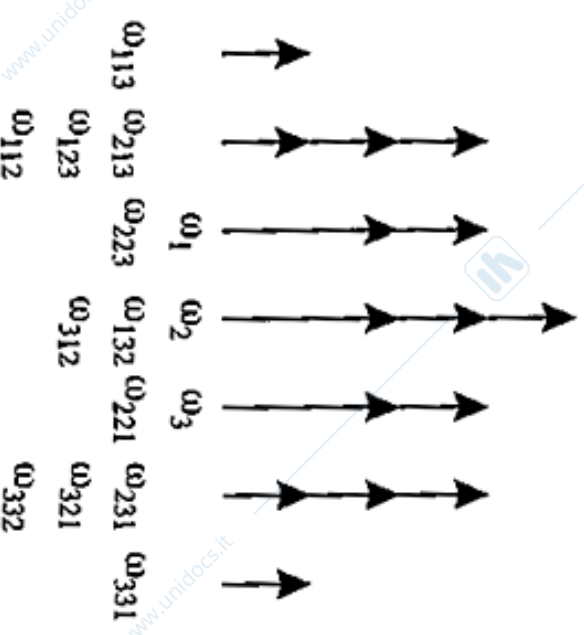

Enabling Technologies – Building Blocks

- ▷ Optical Fibers
- ▷ **Optical Transmitters**
- ▷ Optical Receivers
- ▷ Optical Filters
- ▷ Optical Amplifiers
- ▷ Switching Elements
- ▷ Wavelength Conversion
- ▷ Designing WDM Networks: System Considerations

Optical Transmitter: Laser

- ▷ **Laser: Light Amplification by Stimulated Emission of Radiation**

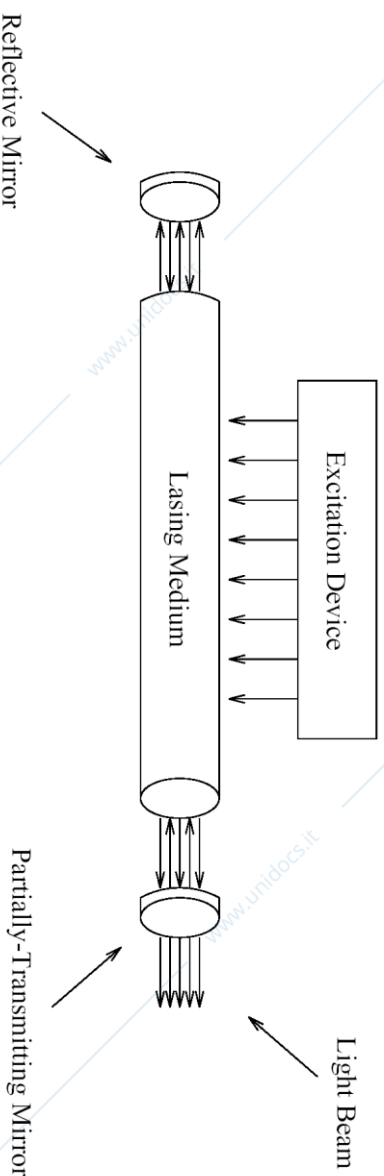

- Three requirements for lasing: 1) gain, 2) feedback, 3) phase-match
- ▷ **Stimulated Emission:** Produces high-power beams of coherent light (same frequency, same propagation direction, and same phase)

Optical Transmitter: Laser

▷ **Energy Levels of an Atom:** transition of electrons from a high-energy state to a lower-energy state releases the energy in a photon

▷ **Quasi-Stable Material and Population Inversion**

→ In certain materials electrons are more likely to stay in the excited energy state

→ Give enough energy (inject photons or electrical current) such that there are more electrons in the higher state than the lower state

Structure of a Semiconductor Diode Laser

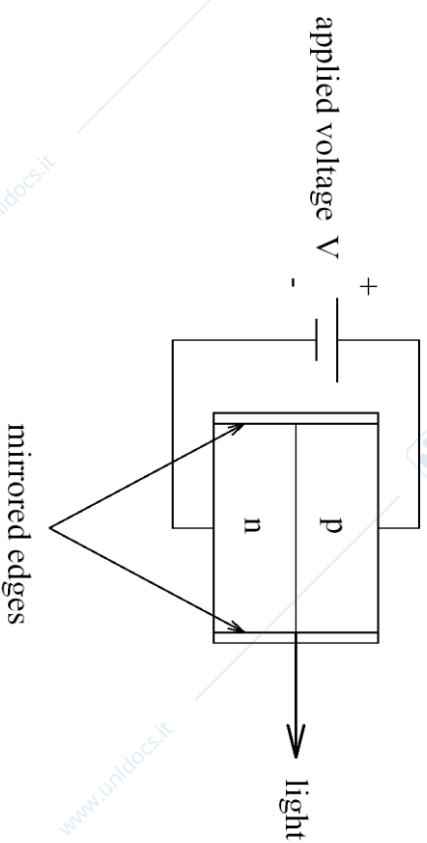

▷ *Bulk Laser Diode*: p-n junction with mirrored edges perpendicular to the junction

▷ *Principle*: Forward voltage applied to the p-n junction such that electrons in the n region can combine with holes from the p region and generate photons.

Laser Characteristics

- ▷ **Linewidth:** Spectral width of the light generated by the laser; affects channel spacing and dispersion
- ▷ **Frequency Instability:** due to
 - *Mode Hopping:* in current-injection lasers, a change in the injection current above a threshold can cause a sudden jump in the lasing frequency
 - *Mode Shift:* changes in frequency due to temperature changes
 - *Wavelength Chirp:* variation in the frequency due to variation in injection current
- ▷ **Number of Longitudinal Modes:** Number of wavelengths that the laser can amplify ($n\lambda = 2L$)
- ▷ **Tuning Range:** Range of wavelengths over which the laser can be operated

Laser Characteristics

- ▷ **Tuning Time:** Time required for the laser to tune from one wavelength to another
- ▷ **Tunability:** Continuously tunable (over its tuning range) or discretely tunable (only to selected wavelengths)

Types of Lasers

- ▷ **Mechanically Tuned Lasers:** Mechanically change the distance between the two mirrors of an external cavity
- ▷ **Acoustooptically and Electrooptically Tuned lasers:** Index of refraction in the external cavity is changed by using either acoustic waves or electrical current
- ▷ **Injection-Current-Tuned Lasers:** Allow wavelength selection with a diffraction grating
 - *Distributed Feedback (DFB):* Bragg grating placed in the active region
 - *Distributed Bragg Reflector (DBR):* Bragg grating placed outside the active region
- ▷ **Laser Array:** A number of lasers integrated into a single component, with each laser operating at a different frequency

Optical Transmitters: Summary

<i>Tunable Transmitter</i>	<i>Approx. Tuning Range (nm)</i>	<i>Tuning Time</i>
Mechanical (external cavity)	500	1–10 ms
Acoustooptic	83	~10 μ s
Electrooptic	7	1–10 ns (estimated)
Injection-Current (DFB and DBR)	10	1–10 ns

Enabling Technologies – Building Blocks

- ▷ Optical Fibers
- ▷ Optical Transmitters
- ▷ **Optical Receivers**
- ▷ Optical Filters
- ▷ Optical Amplifiers
- ▷ Switching Elements
- ▷ Wavelength Conversion
- ▷ Designing WDM Networks: System Considerations

Optical Receivers: Photodetection

▷ Direct Detection:

- A photodetector converts the incoming photonic stream into a stream of electrons
- The electron stream (current) is then amplified and passed through a threshold device
- Whether a bit is a logical 0 or 1 depends on whether the stream is above or below a certain threshold for a bit duration
- It can be implemented, e.g., with a p-n junction

Structure of a p-n junction photodiode

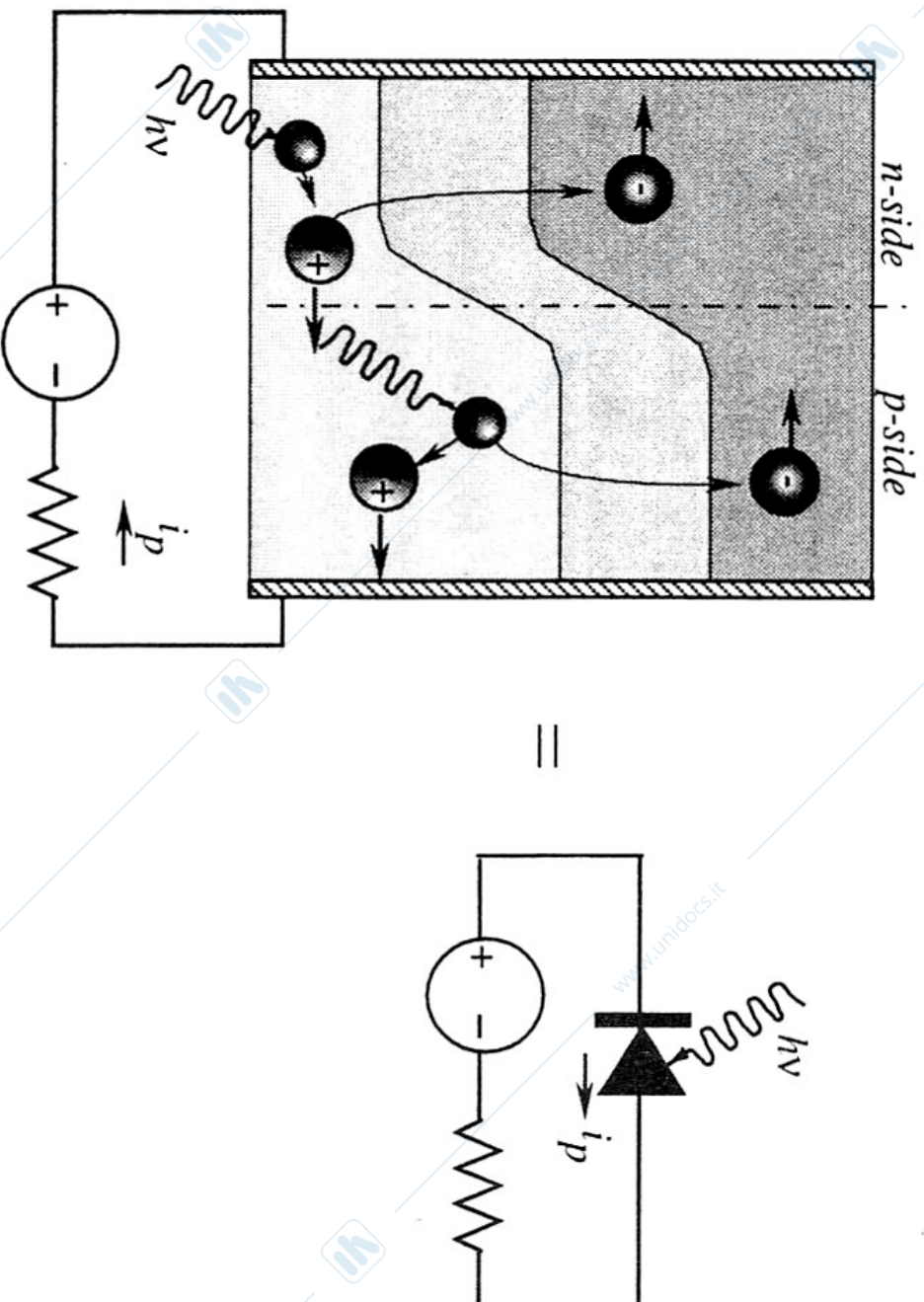

FIGURE 13.3. Structure of a photodiode.

Optical Receivers: Photodetection

▷ Coherent Detection:

- Phase information is used in the encoding and detection of signals
- Receiver uses a laser as local oscillator
- Incoming signal is combined with the signal oscillator (at a slightly different frequency), resulting in a signal at the difference frequency
- This difference signal (in the microwave range) is amplified and then photodetected

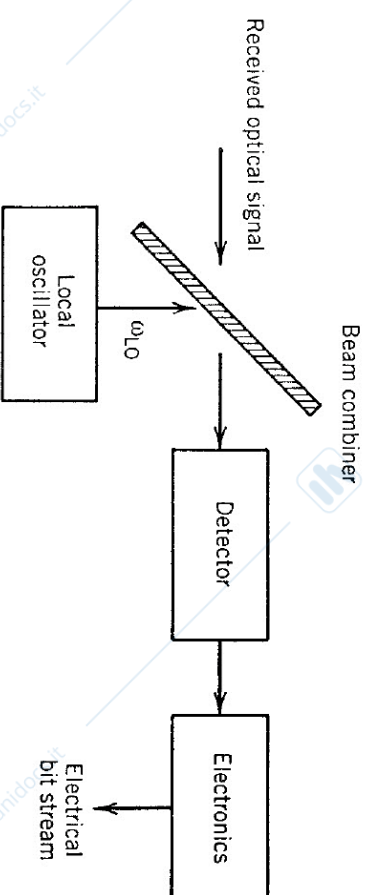

Figure 1: Schematic illustration of a coherent detection scheme.

Enabling Technologies – Building Blocks

- ▷ Optical Fibers
- ▷ Optical Transmitters
- ▷ Optical Receivers
- ▷ **Optical Filters**
- ▷ Optical Amplifiers
- ▷ Switching Elements
- ▷ Wavelength Conversion
- ▷ Designing WDM Networks: System Considerations

Types of Tunable Filters (1)

- ▷ **The Etalon**: Single cavity formed by two parallel mirrors; by adjusting the distance between the mirrors, a single wavelength can be selected to propagate through
- ▷ Its primary optical property is that if a monochromatic light ray travels back and forth between two mirrors, and the distance between mirrors is equal to an integral number of wavelengths, then the light passes through the etalon

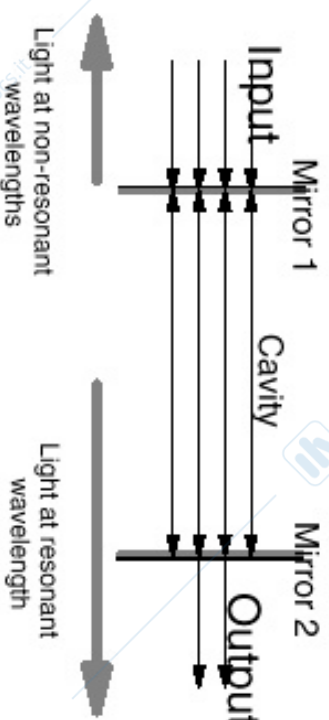

Types of Tunable Filters (2)

▷ **The Mach-Zehnder (MZ) Chain (interferometer)** : Splits the incoming wave into two waveguides, and recombines the signals at the outputs. An adjustable delay element sets a phase difference between the two signals. Wavelengths for which the phase difference is 180° are filtered out.

- ▷ By a chain of MZs a specific wavelength can be selected
- ▷ By adjusting the optical path length of one arm (therefore the phase of the signal in that arm), the filter can be tuned

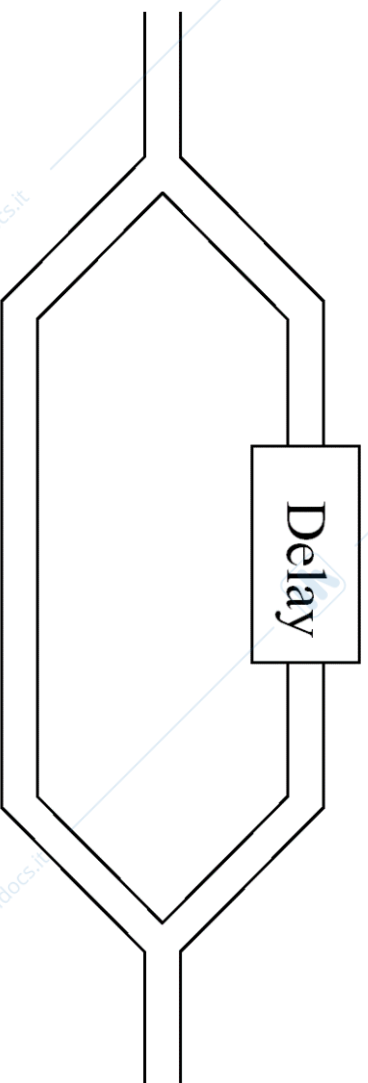

Types of Tunable Filters (3)

Fiber Bragg Grating

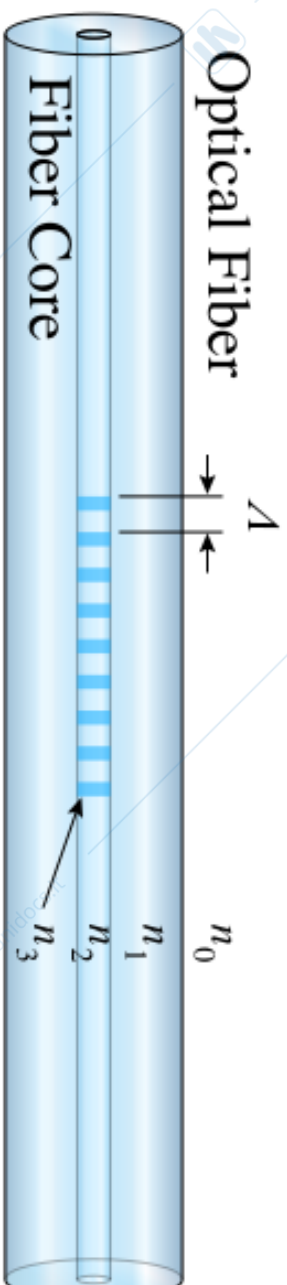

Core Refractive Index

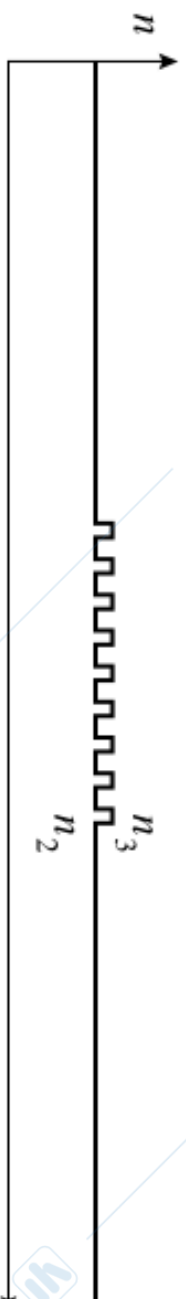

Spectral Response



Tunable Filter Characteristics

- ▷ **Tuning Range**
- ▷ **Tuning Time**

▷ **Free Spectral Range (FSR)** : Filters usually have periodic resonant frequencies. The distance between two neighboring resonant frequencies is called FSR

▷ **Finesse**: A measure of sharpness of the resonance. It is the ratio of FSR to the 3-dB bandwidth of a resonant peak

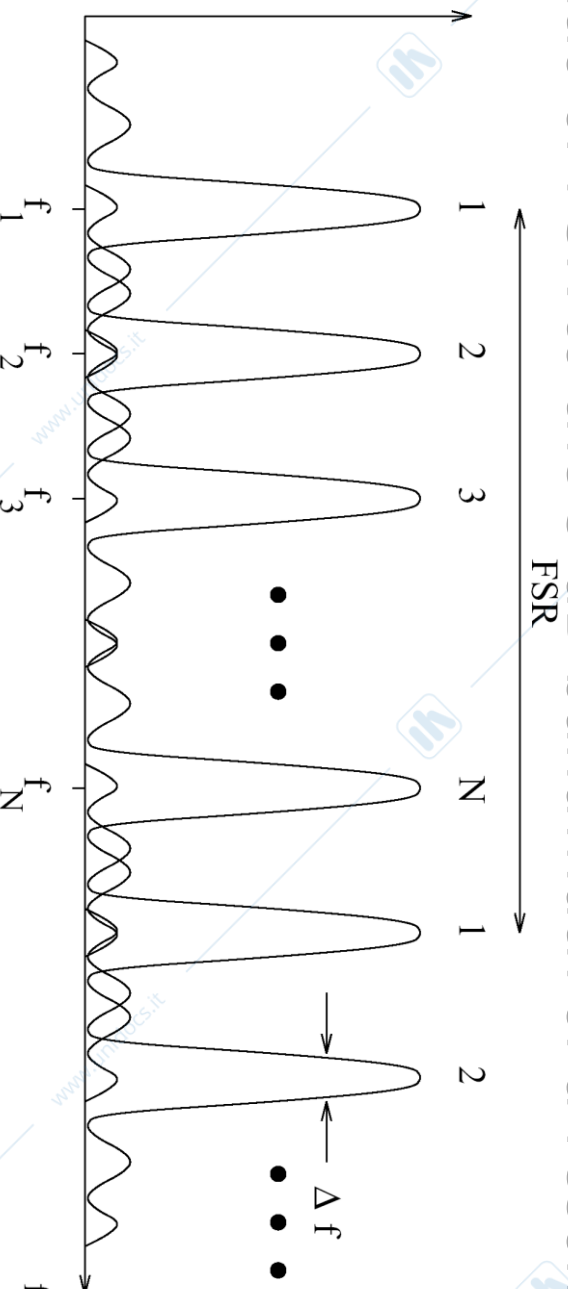

$$\text{finesse} = \frac{\text{FSR}}{\Delta f}$$

Cascading Filters with Different FSRs

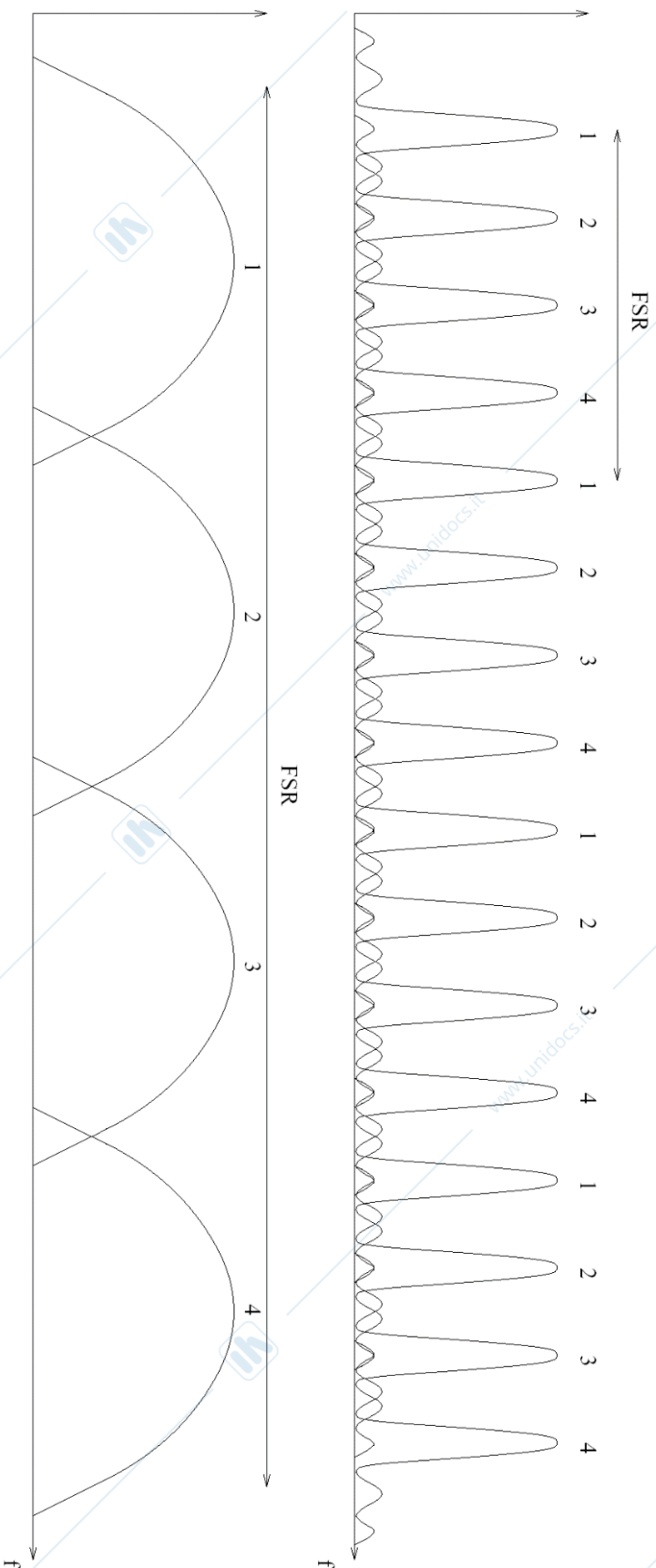

Types of Tunable Filters (4)

- ▷ **Etalon**: it can be mechanically tuned
- ▷ **Acoustooptic Tunable Filters (AOTF)**: RF waves are passed through a transducer that generates acoustical (mechanical) waves in the waveguides. The refractive index changes accordingly and can be constructed into a grating. This grating can select a certain wavelength.
- ▷ **Electrooptic Filters**: Use crystals whose refractive indices can be changed by electrical currents
- ▷ **Liquid-Crystal Fabry-Perot Filters**: An FP cavity filled with liquid crystal, whose refractive index can be changed by electrical current

Optical Filters: Summary

- ▷ **Fixed Filters:**
 - Grating Filters
 - Fiber Bragg Gratings
 - Thin-Film Interference Filters

- ▷ **Tunable Filter Summary:**

<i>Tunable Receiver</i>	<i>Approx. Tuning Range (nm)</i>	<i>Tuning Time</i>
Fabry-Perot	500	1-10 ms
Acoustooptic	250	~10 μ s
Electrooptic	16	1-10 ns
LC Fabry-Perot	30	0.5-10 μ s

Enabling Technologies – Building Blocks

- ▷ Optical Fibers
- ▷ Optical Transmitters
- ▷ Optical Receivers
- ▷ Optical Filters
- ▷ **Optical Amplifiers**
- ▷ Switching Elements

- ▷ Wavelength Conversion
- ▷ Designing WDM Networks: System Considerations

Optical Amplifiers

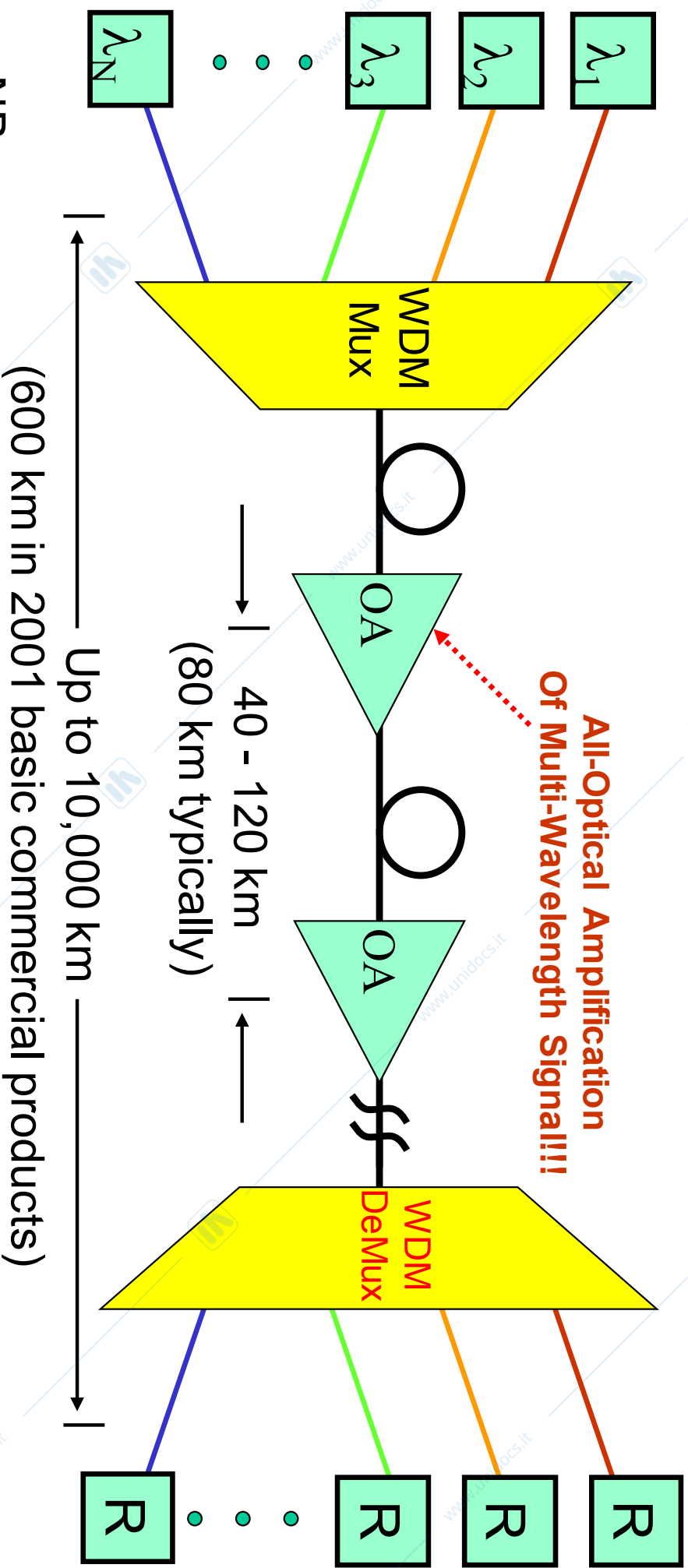

>NB:

>In general signal regeneration can be 1R, 2R or 3R

> Pulse re-amplification, re-shaping, re-timing

>Optical amplification is 1R

The problem of ASE and OSNR

- The Optical Signal-to-Noise Ratio (OSNR) is the fundamental quality parameter

OSNR must be above a threshold O_t to preserve quality

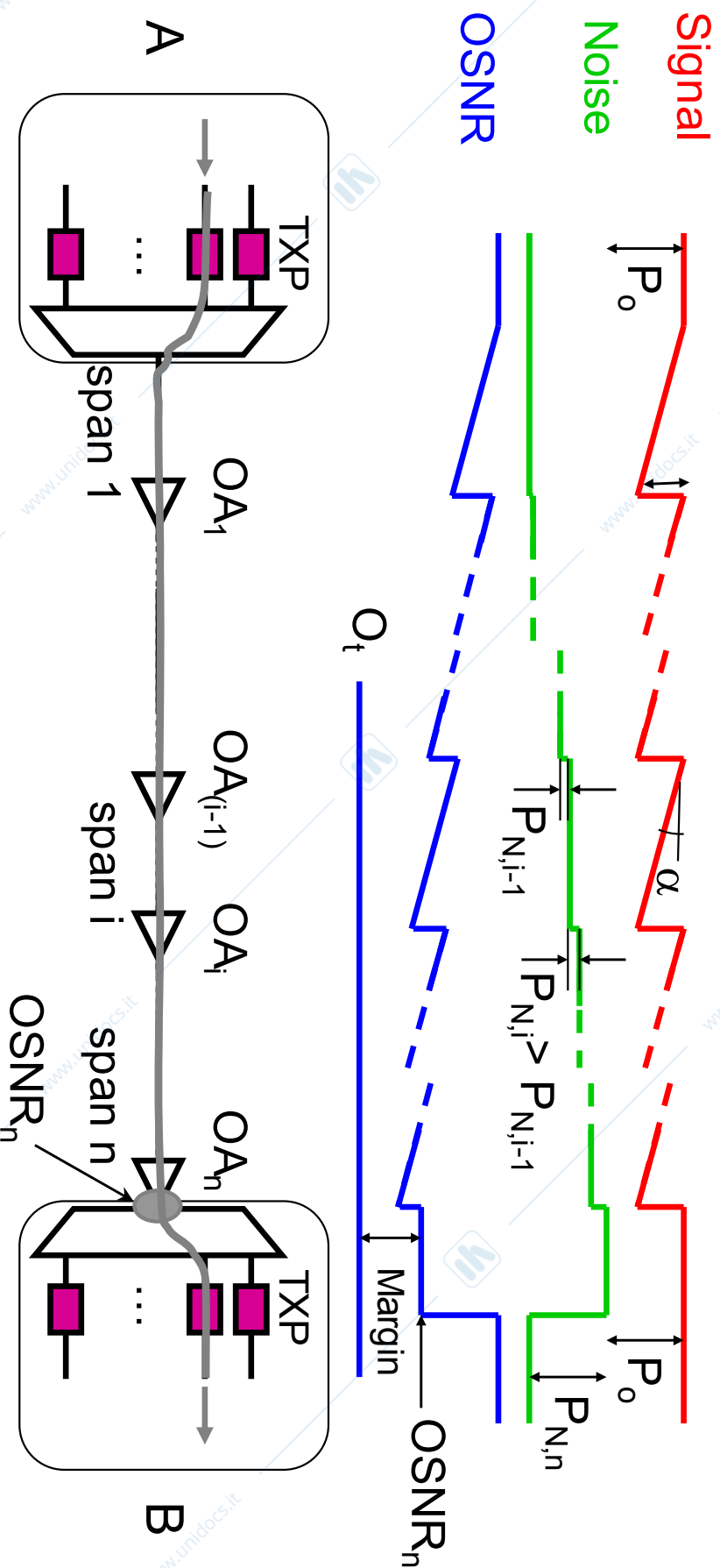

Optical Amplifier Characteristics

- ▷ **Gain**: Ratio of the output power of a signal to its input power
- ▷ **Gain Efficiency**: Measures the gain as a function of pump power in dB/mW
- ▷ **Gain Bandwidth**: Range of frequency over which the amplifier is effective
- ▷ **Gain Saturation** Value of output power at which the output power no longer increases with an increase in the input power
- ▷ **Polarization Sensitivity**: Dependence of the gain on the polarization of the signal – measured in dB and refers to the gain difference between the TE and TM polarizations
- ▷ **Amplified Spontaneous Emission (ASE)**: Dominant source of noise, which arises from the spontaneous emission

A Semiconductor Optical Amplifier

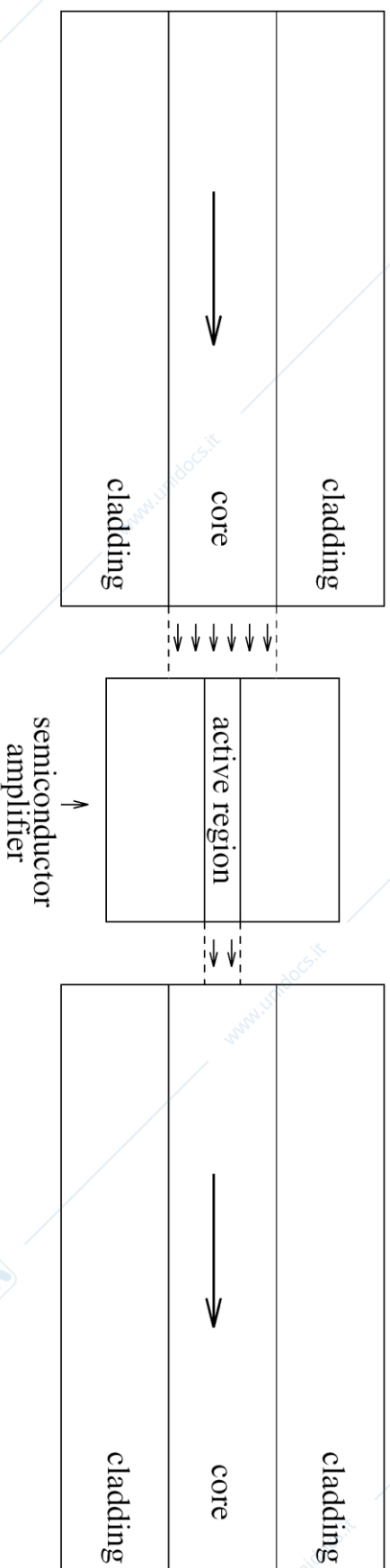

- ▷ Pro's: based on stimulated emission, simplicity
- ▷ Con's: limited gain, polarization sensitive

Erbium-Doped Fiber Amplifier

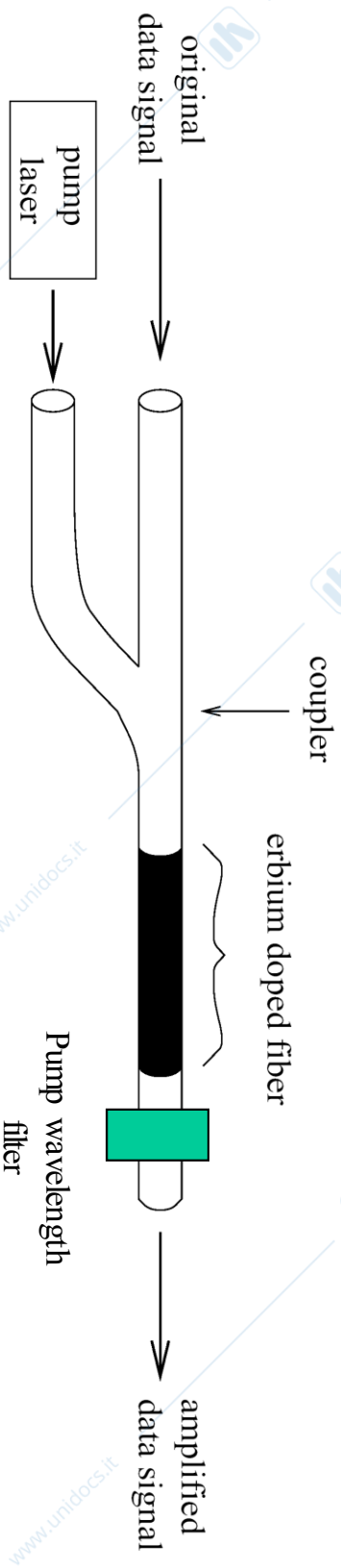

▷ Gain Spectrum of an EDFA

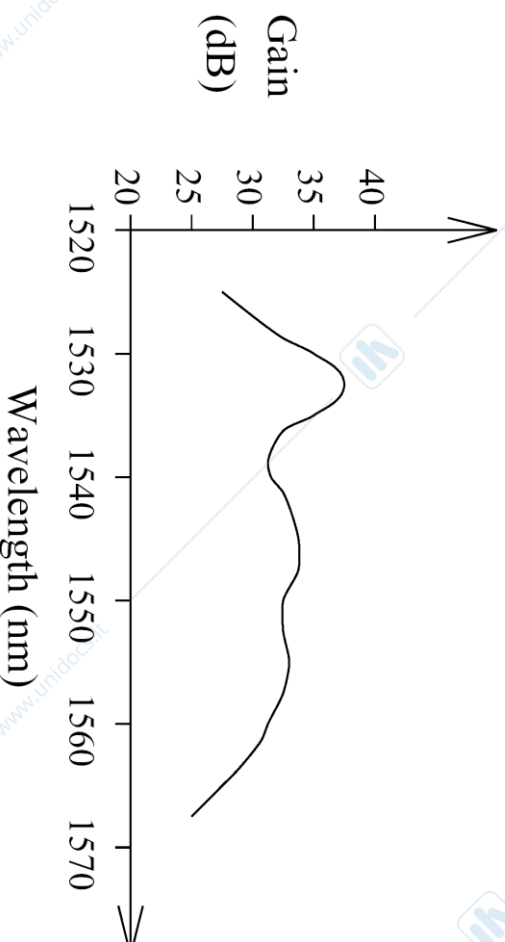

Optical Amplifiers: Summary

<i>Amplifier Type</i>	<i>Gain Region</i>	<i>Gain Bandwidth</i>	<i>Gain</i>
Semiconductor	Any	40 nm	25 dB
EDFA	1525–1560 nm	35 nm	25–51 dB
PDFFA	1280–1330 nm	50 nm	20–40 dB

PDFFA (different rare-earth element): praseodymium-doped fluoride fiber amplifier

Enabling Technologies – Building Blocks

- ▷ Optical Fibers
- ▷ Optical Transmitters
- ▷ Optical Receivers
- ▷ Optical Filters
- ▷ Optical Amplifiers
- ▷ **Switching Elements**
- ▷ Wavelength Conversion
- ▷ Designing WDM Networks: System Considerations

Optical Switching

1. Basics of switching
2. Overview of the main optical switching devices, roughly ordered according to complexity
 - ▷ Splitters
 - ▷ Passive star couplers
 - ▷ Demultiplexers (AWG)
 - ▷ Crosspoints (elementary switching elements)
 - ▷ Gate switch
 - ▷ Mems
 - ▷ Others..
 - ▷ F-OADM vs R-OADM
 - ▷ OXC
 - ▷ Active vs. Passive wavelength router
 - ▷ Additional slides: WSS and WSS-based ROADM

Switching Elements: Basics

- ▷ 1° classification: electrical vs. optical switching
 - ▷ You can have optical networks with electronic switching!
 - ▷ In this section emphasis on optical switching
 - ▷ Transparent vs Opaque Switching
- ▷ 2° classification: Circuit vs. Cell (Packet) Switching
 - ▷ In optical networks:
 - ▷ Wavelength vs. Packet (Burst) Switching
- ▷ 3° Classification: Logic vs. Relational Switching



Electrical vs. Optical Switching

Different flavours of OXC Configurations

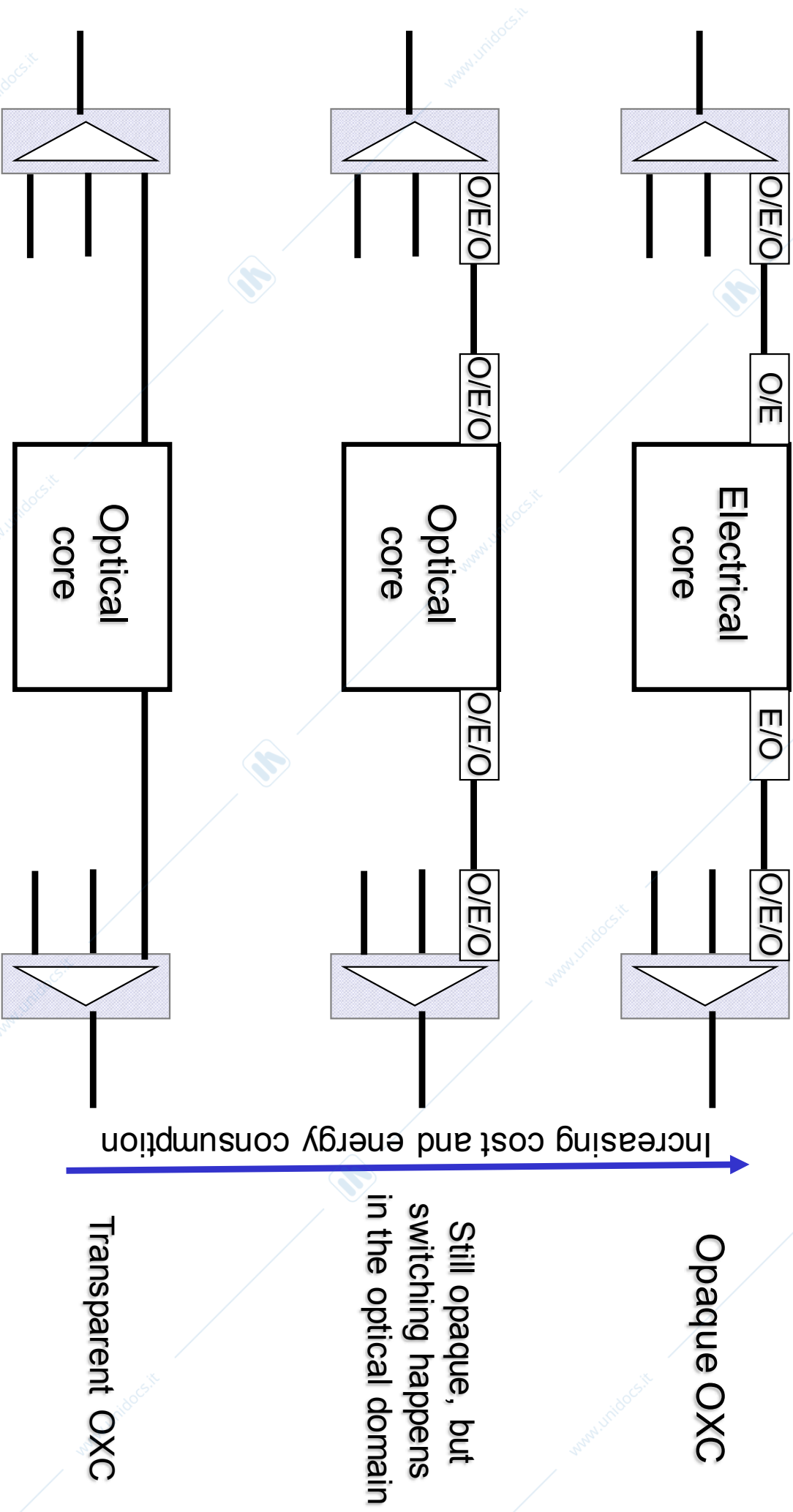

Opaque OXC

Still opaque, but switching happens in the optical domain

Transparent OXC



Packet vs. Circuit Switching

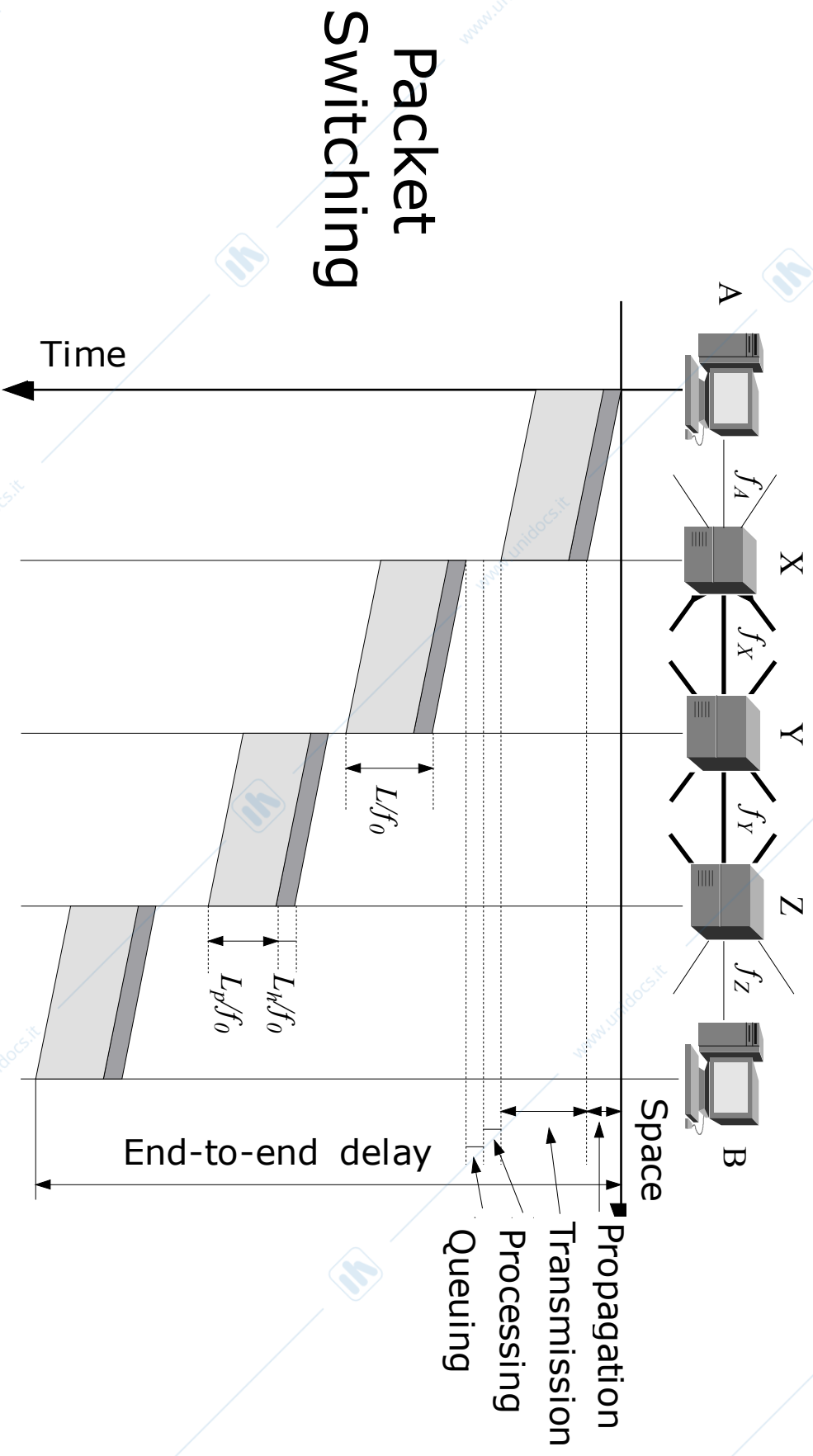

Packet Switching



Packet vs. Circuit Switching

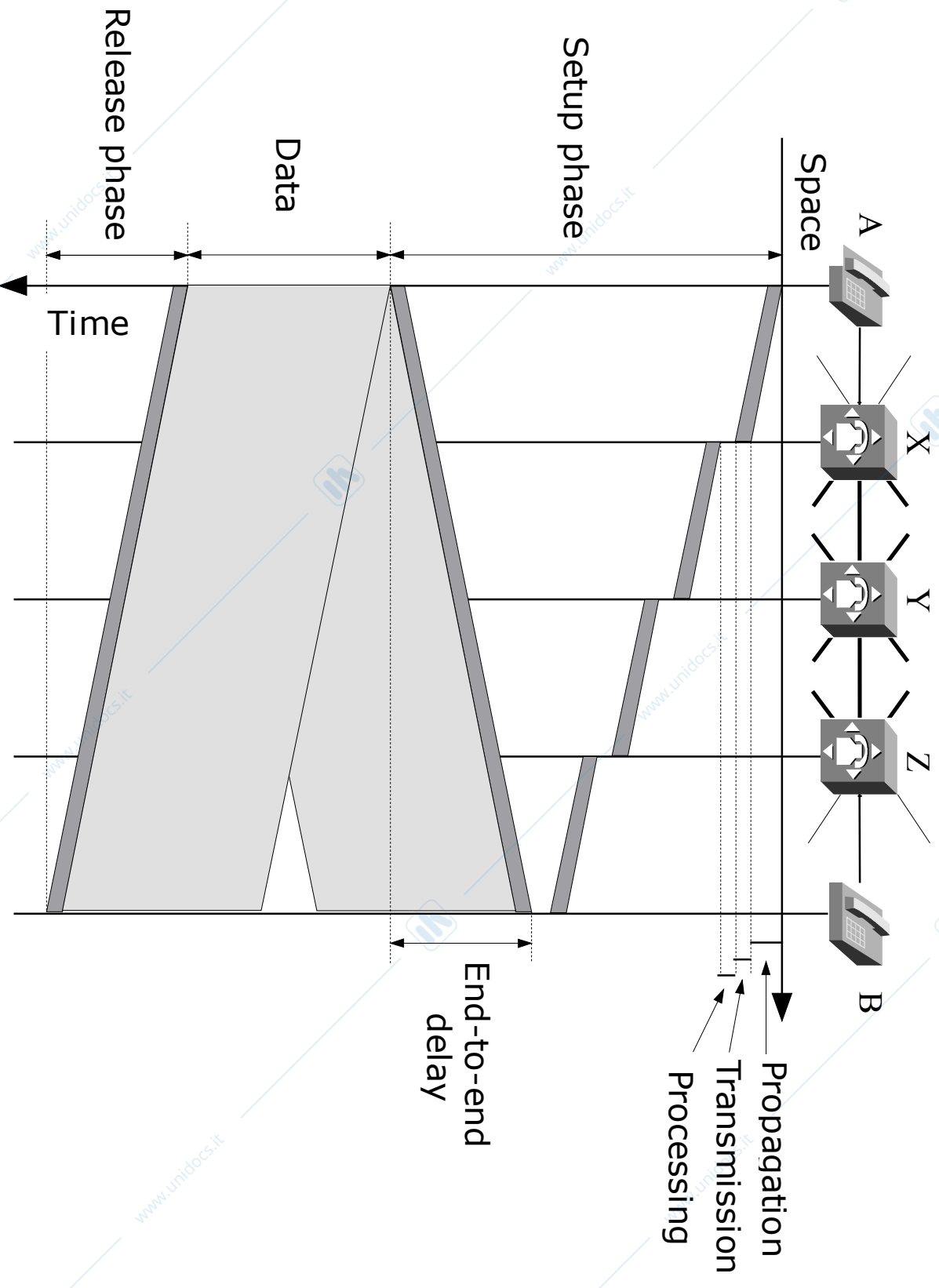

Circuit Switching

Splitter, Combiner, and Coupler

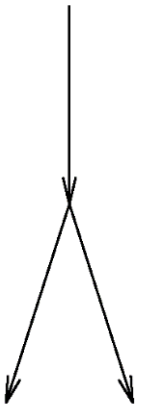

(a) splitter



(b) combiner

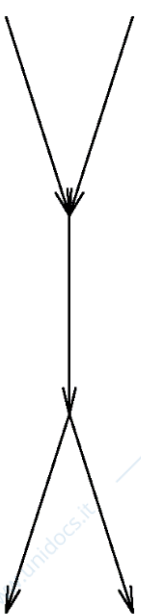

(c) coupler

- ▷ *Splitting Ratio*: Most common = 50:50 for a two-port splitter
- ▷ *Return loss*: Small amount of power is reflected back to the coupler input (40-50dB below)
- ▷ *Insertion Loss*: Imperfect alignment

Passive-Star Coupler

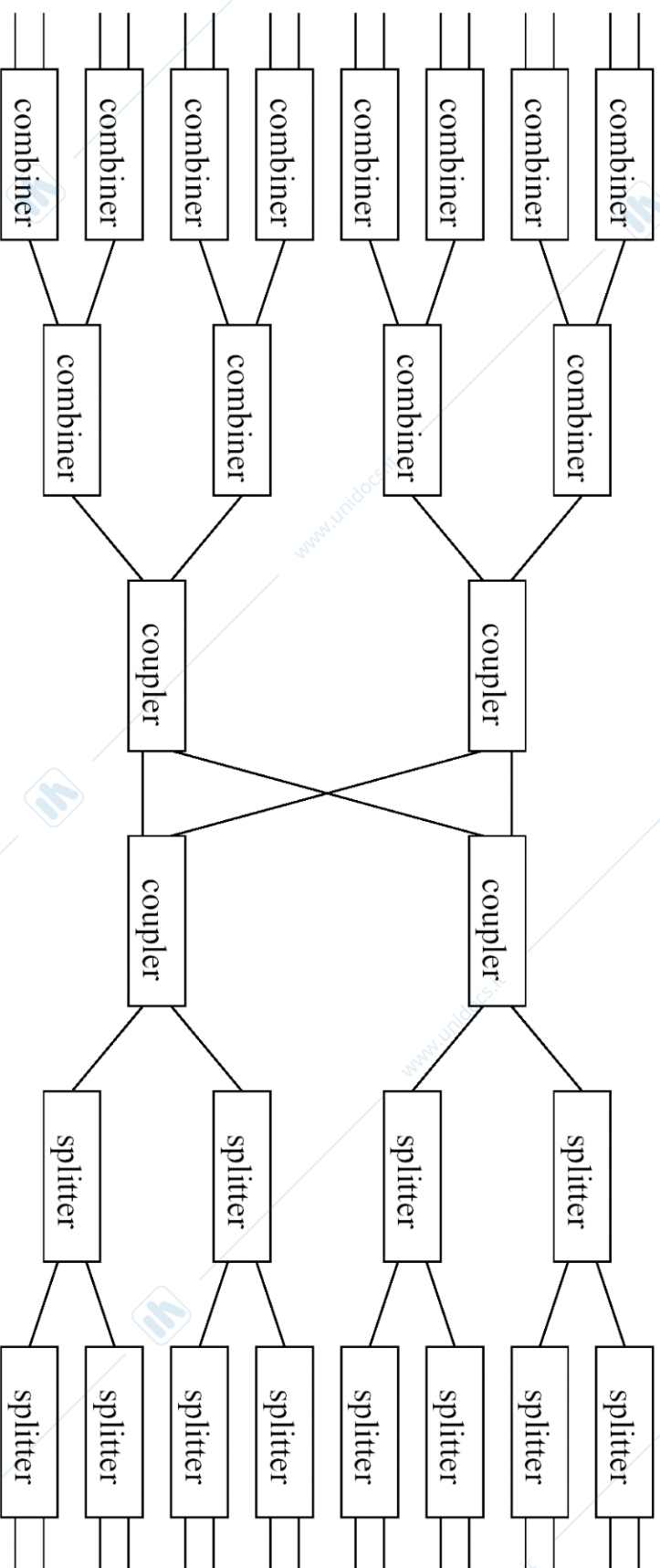

- ▷ This is a *non-ideal* implementation – too much loss!
- ▷ What is an ideal implementation? ($P_{\text{out}}=P_{\text{in}}/N$)

A “first” crossconnect – the Passive Star

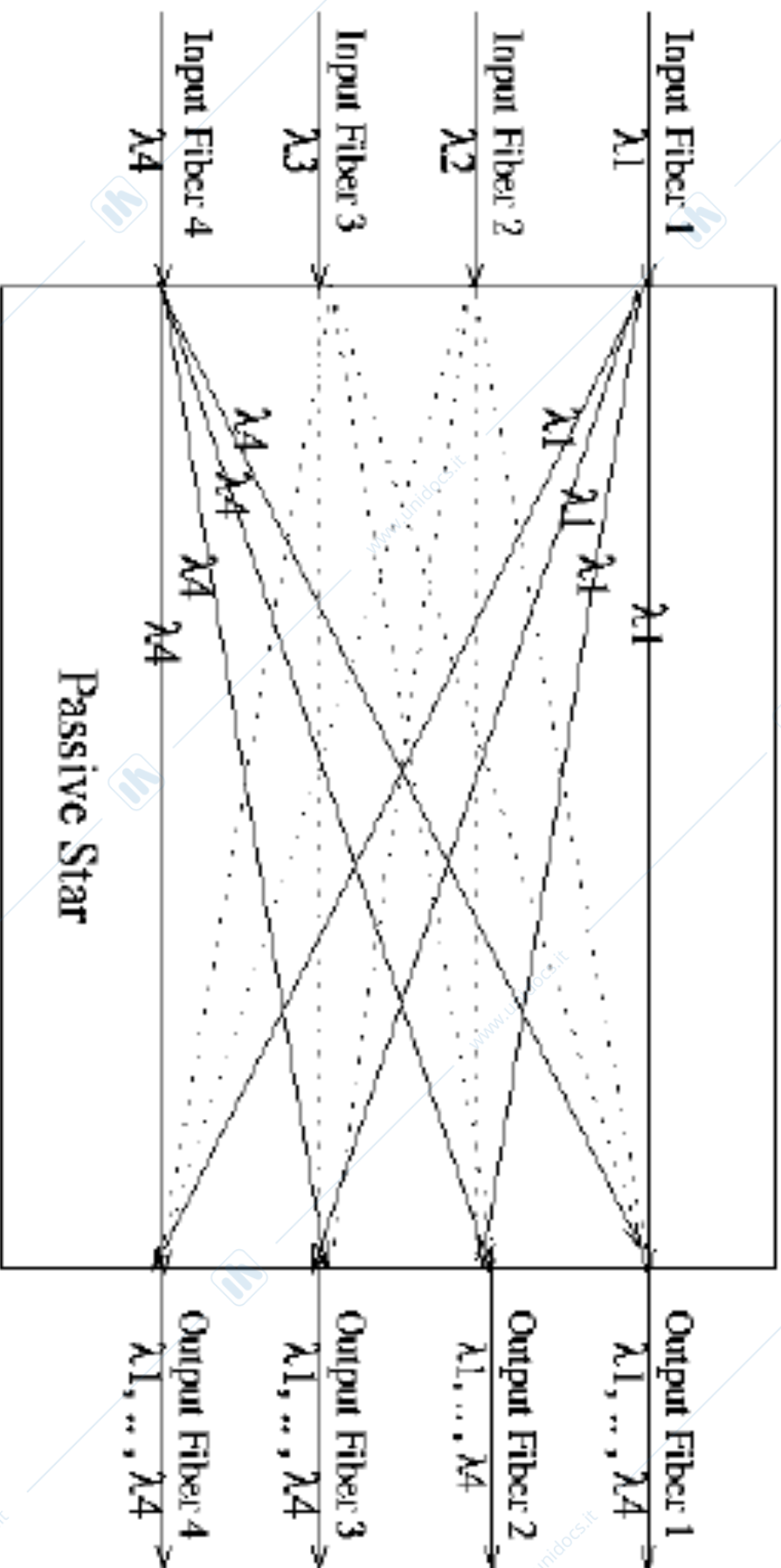

▷ $N \times N$ star can route N simultaneous connections, all in broadcast mode

▷ Condition to be respected: different input- > different wavelengths!!

Demultiplexers

- ▷ An optical demultiplexers receives multiple signals at different frequencies from a single fiber and separates them into as many individual fibers as the frequencies
- ▷ It can be implemented using :
 - ▷ Prisms (Fig. 5.1)
 - ▷ Filters (Fig. 5.2)
 - ▷ Diffraction gratings (Fig. 5.3)
- ▷ But the most common approach is AWG

▷ See next slide

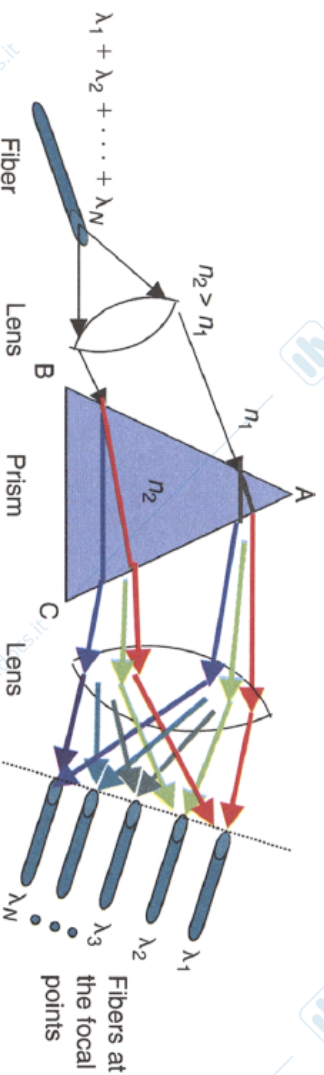
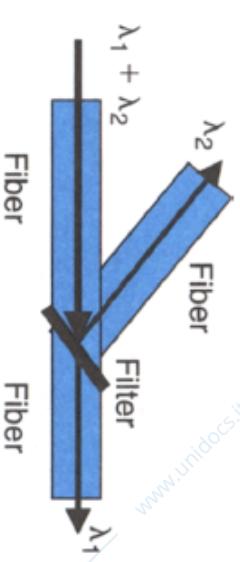

Figure 5.1 When a collimated beam of polychromatic light impinges on a prism surface, each wavelength component is refracted differently.



(a)

Figure 5.4 Spectral filters: (a) with a filter

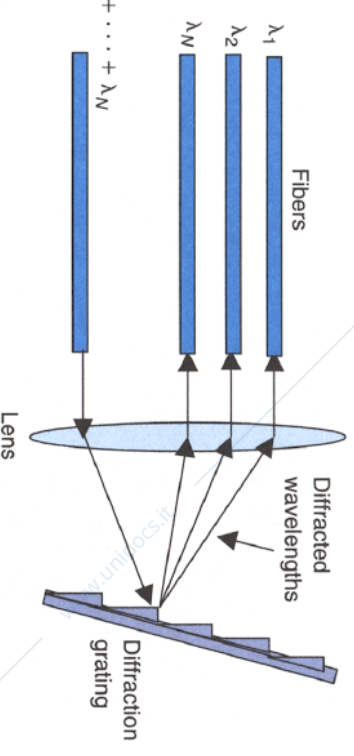

Figure 5.2 When a collimated polychromatic light beam impinges on a diffraction grating, each wavelength component is diffracted and directed to a different point in space.

Arrayed Waveguide Grating (1)

as demux

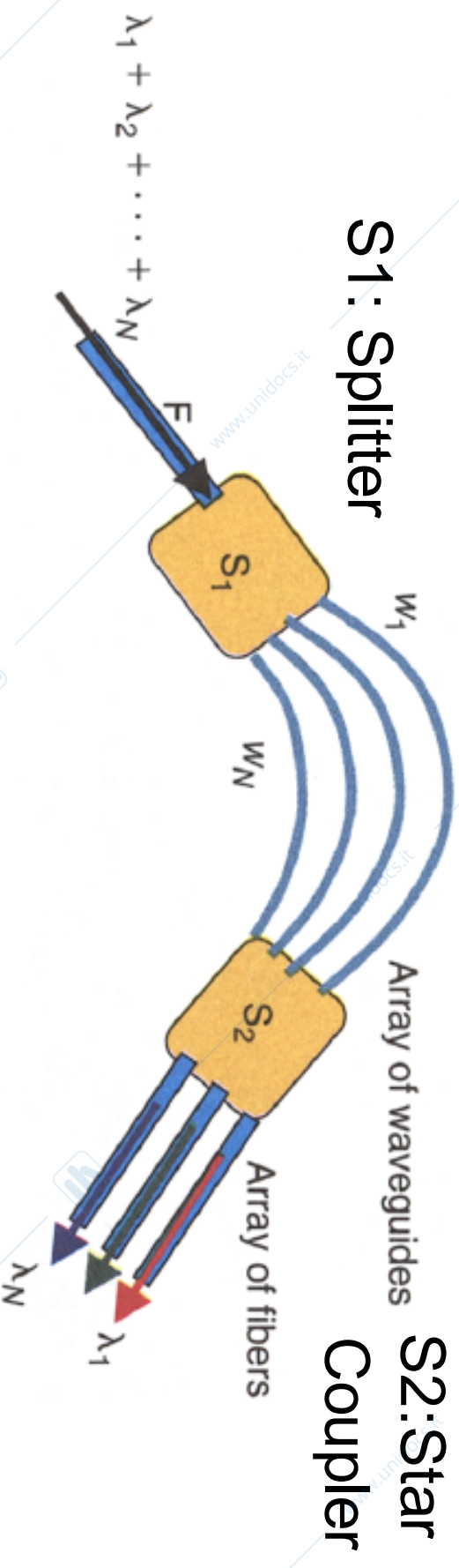
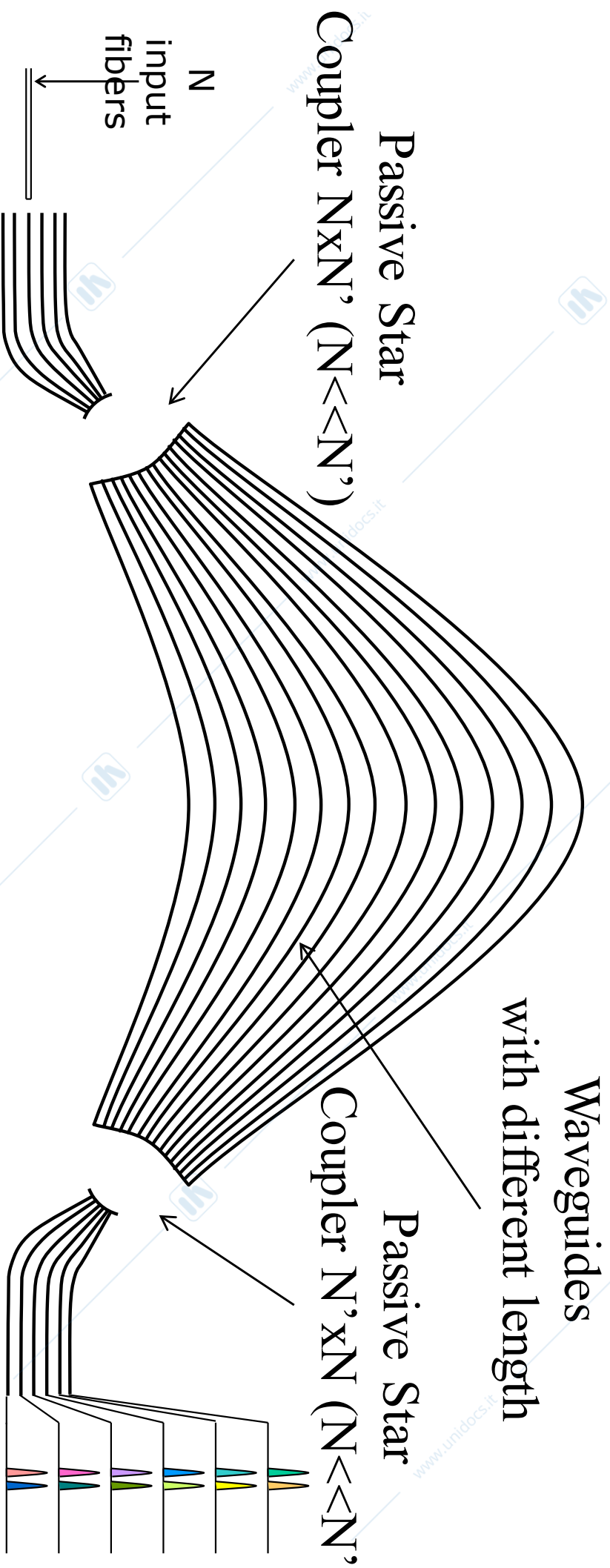

Figure 5.3 Arrayed waveguide gratings are constructed on the basis of the principle of interferometry.

Arrayed Waveguide Grating (2)

as waveguide grating router (WGR)



Lengths of waveguides are chose in such a away that the signals interfere constructively only at one port

Arrayed Waveguide Grating (3)

- The previous figure shows a schematic representation of the AWG.
 - The device consists of two star couplers, connected by a grating array (an array of curved-channel waveguides with a fixed difference in the length of optical path between the adjacent channels).
- The operation principle is as follows.
 - Arrayed-waveguide gratings (AWG) are based on the principles of diffractions. AWG is a generalization of the Mach-Zehnder interferometer.
 - When light enters the input star coupler, it is replicated to each input of the waveguide array. There the optical path difference of each waveguide creates phase delays in the output cavity, where an array of fibers is coupled. The process results in different wavelengths having constructive interference at different locations, where the output ports are aligned.

2X2 Crossconnect Elements

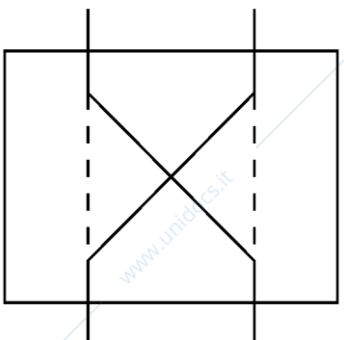

cross state

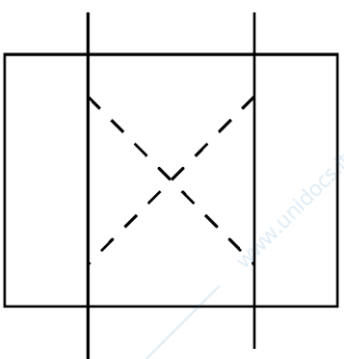

bar state

Schematic of Optical Crosspoint Elements

Realizations of directive switches

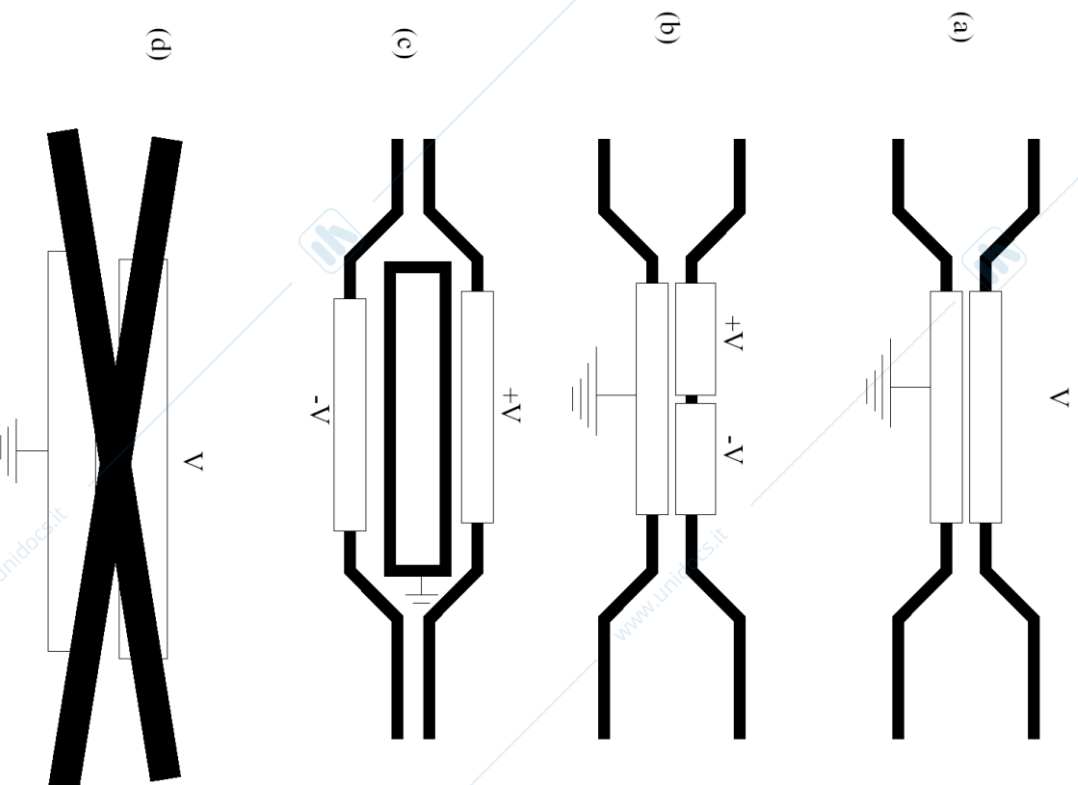

- ▷ Two waveguides are put in close proximity
- ▷ (a) Directional coupler (light couples via evanescent coupling)
- ▷ (b) Reversed delta-beta coupler
- ▷ (c) Balanced-bridge interferometric switch
- ▷ (d) Intersecting waveguide switch

A 2X2 Amplifier Gate Switch

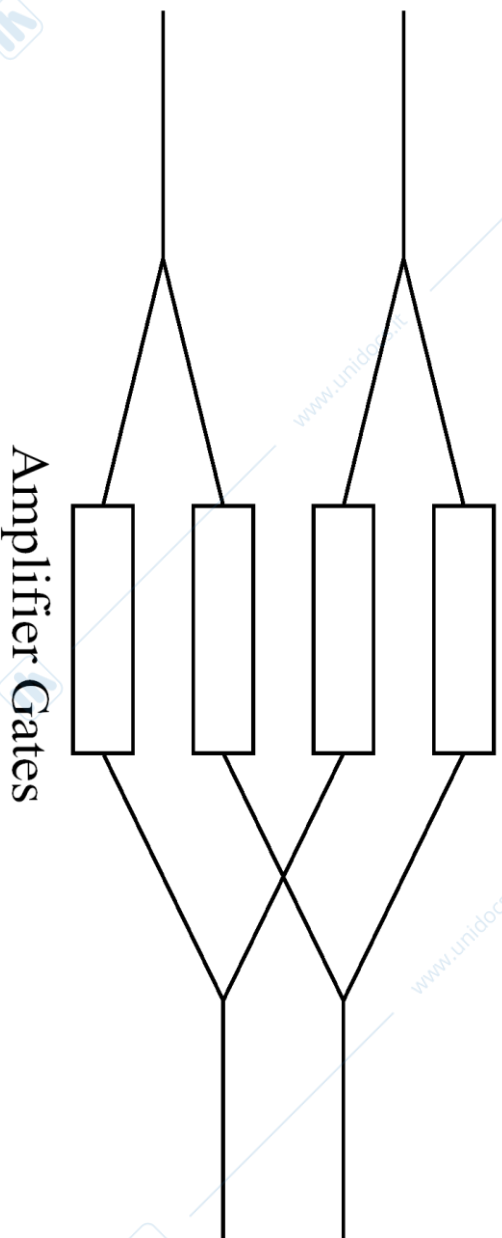

All-Optical Switching: MEMS

- MEMS = micro-electro-mechanical system
- Movable mirrors to deflect light
- 2D MEMS (a two-state pop-up MEMS mirror)

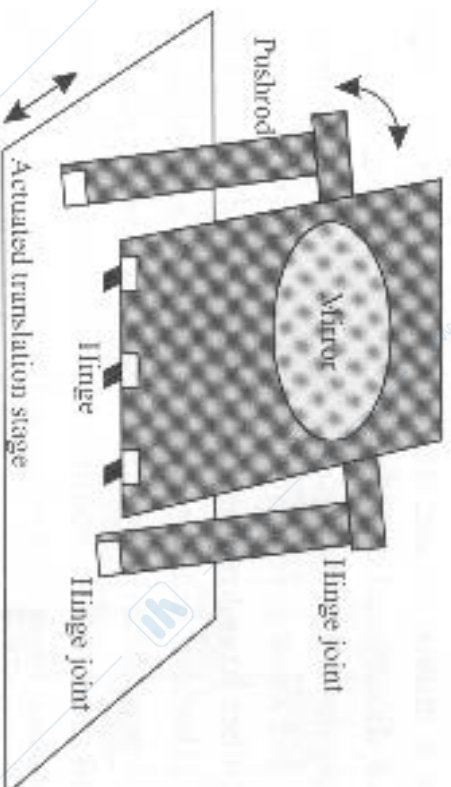

- State “0” = popped up position (as above)
- State “1” = flat (or folded) position

MEMS (contd.)

- 3D-MEMS

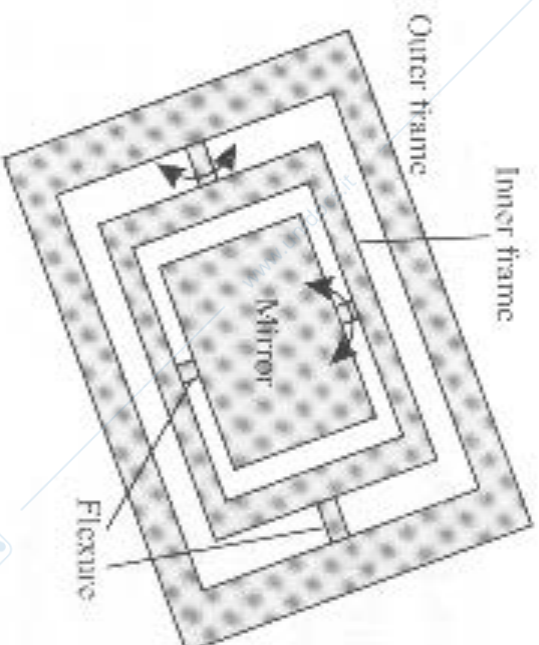

- Mirror can be freely rotated on two axes to deflect a light beam

3D MEMS Example (NxN Switch)

- Using two arrays of 3-D MEMS mirror

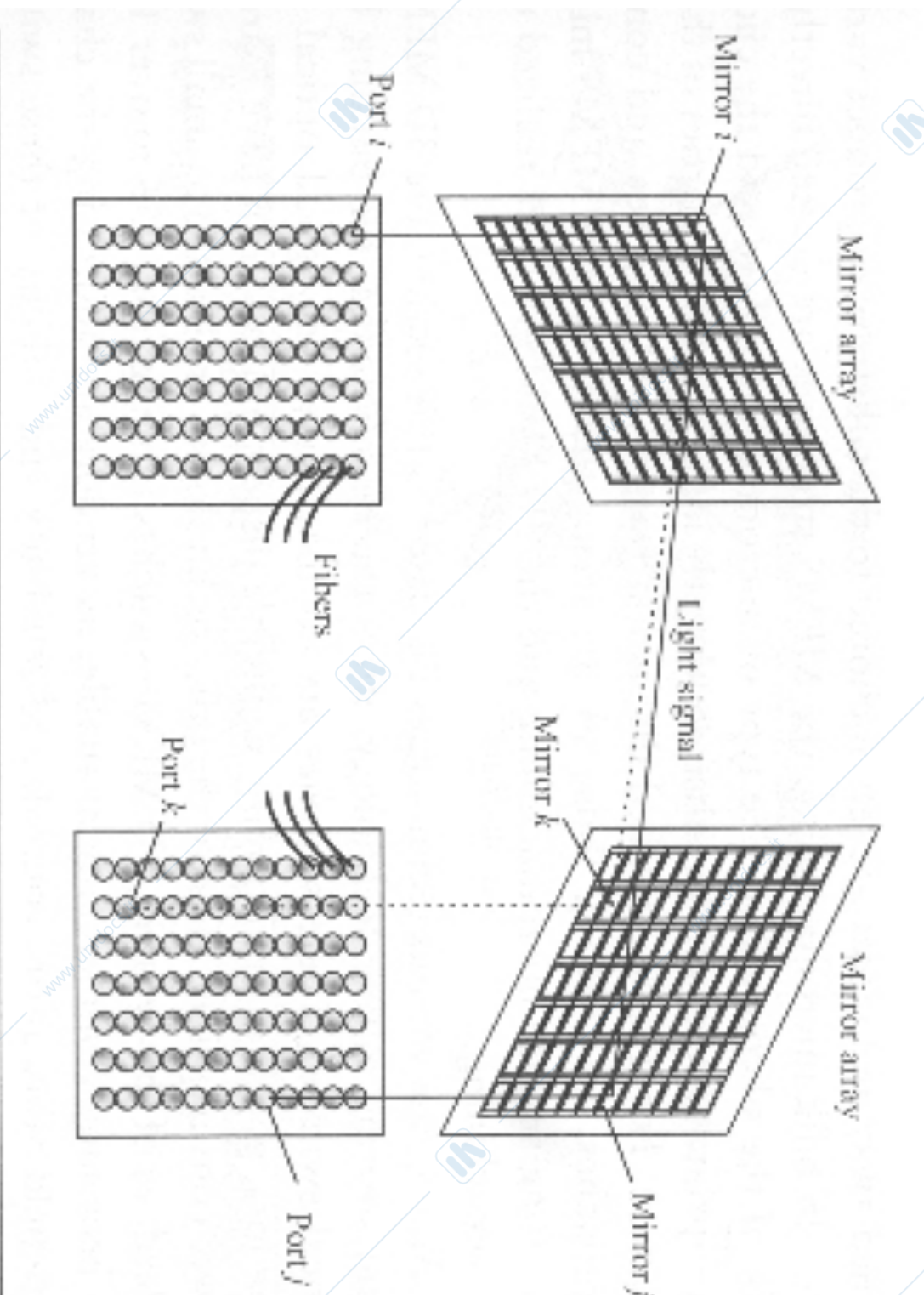

Crossbar architecture

The case of 2-D MEMS

- 2-D MEMS with free-space interconnections
- Complexity: N^2

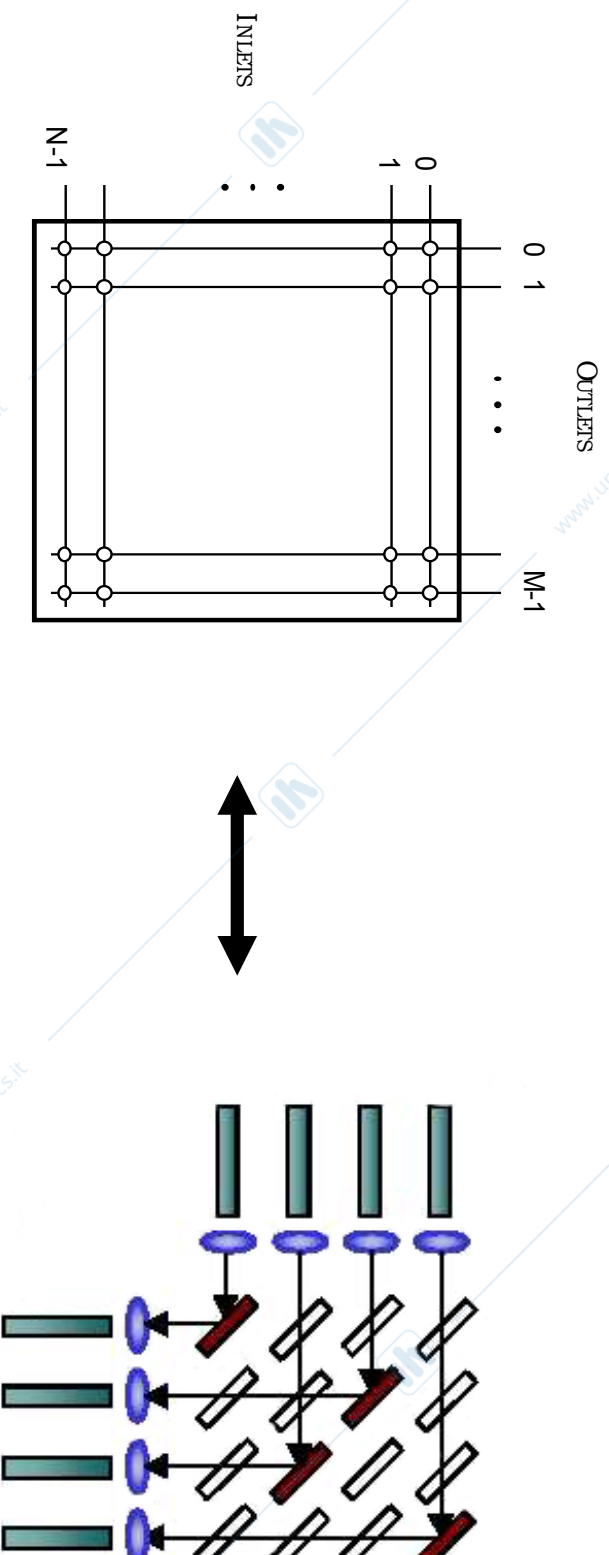

Other All-Optical Switches

- Bubble-based switches
- Liquid crystal switches
- Electro-optic switches (LiNbO₃)
- Thermo-optic switches
- SOA switches
- Holographic switches
- See Lightreading Article on “All-Optical Switching Technologies”

F-OADM vs R-OADM

- **Fixed Optical Add-Drop Multiplexer (F-OADM)**
 - Fixed add/drop/bypass of a small number of wavelengths
 - 1 fiber in, 1 fiber out
- **Reconfigurable Optical Add-Drop Multiplexer (F-OADM)**
 - Same as F-OADM, but add/drop/bypass can be reconfigured
 - Here we show traditional non-WSS-based implementation (WSS-based implementation in separate slides)
 - 1 fiber in, 1 fiber out
- **Optical Crossconnect (OXC)**
 - Fully-flexible connectivity of input/output wavelengths
 - N fiber in, N fiber out

Fixed Optical Add/Drop Multiplexer (F-OADM)

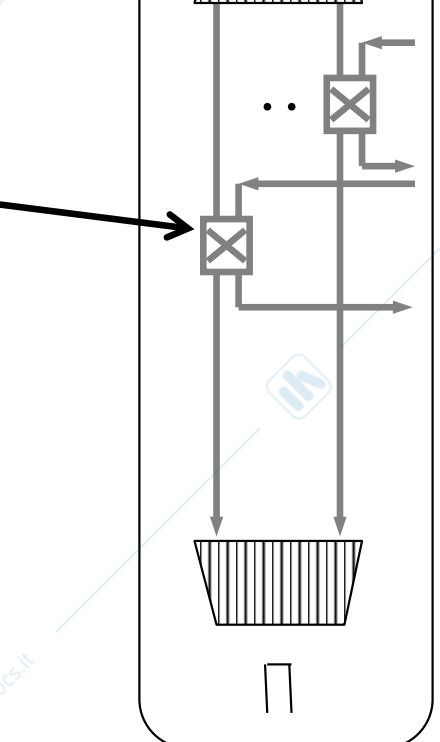
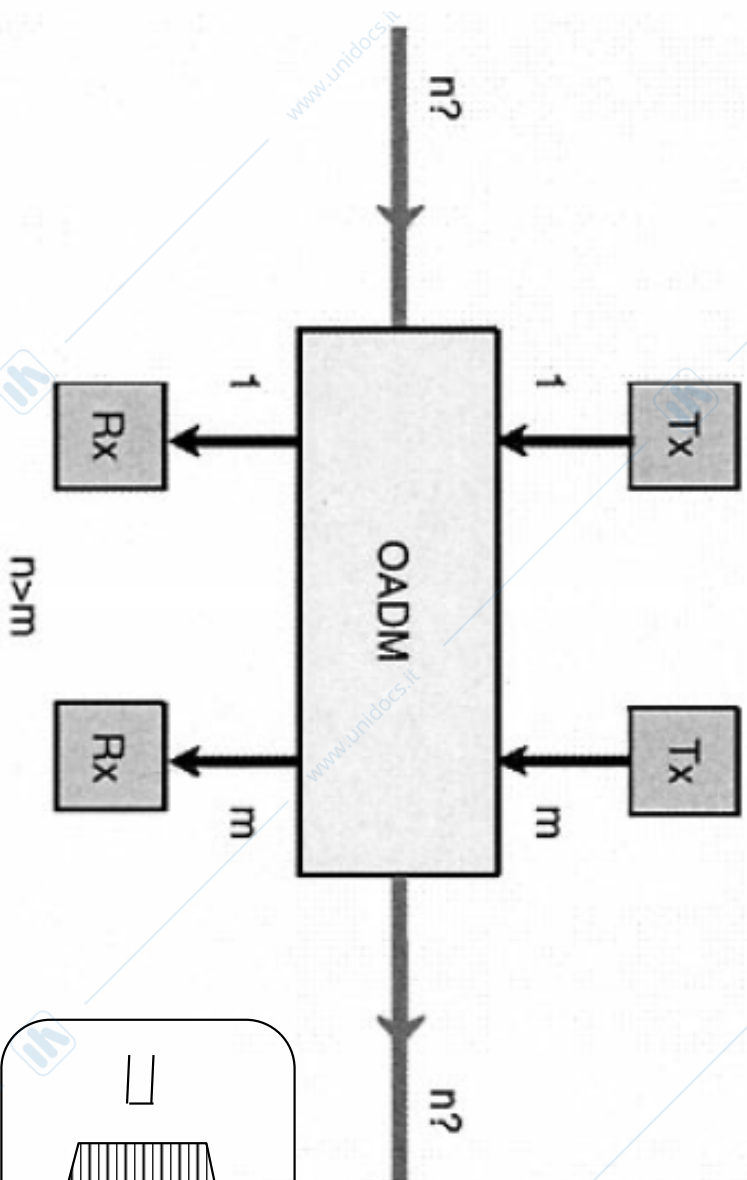

Generic OADM architecture.

**Fixed configuration.
Requires manual intervention**

Reconfigurable Optical Add/Drop Multiplexer (R-OADM)

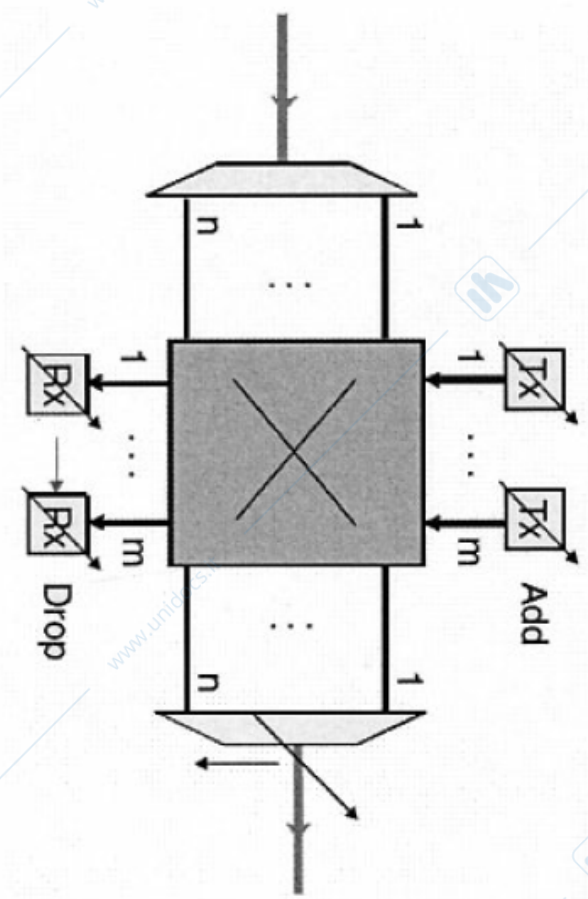

(a) WS OADM architecture

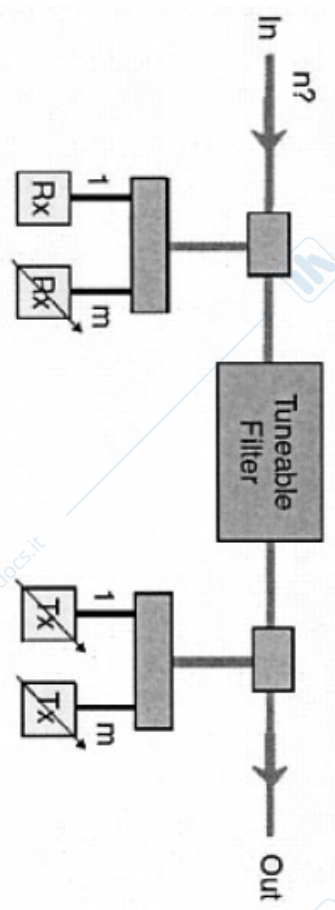

(b) BS OADM architecture

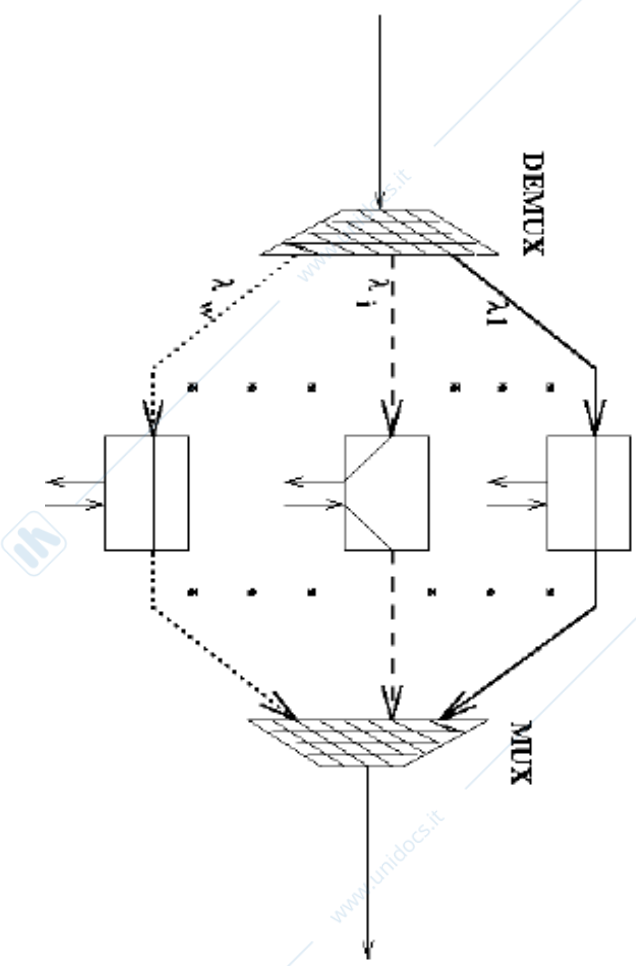

Non-Reconfigurable Wavelength Router vs OXC

- **Non-Reconfigurable Wavelength Router**
 - Rigid/fixed connectivity of wavelengths between N fiber in, N fiber out
- **Optical Crossconnect (OXC)**
 - ..a.k.a. “reconfigurable wavelength router”
 - Flexible connectivity of wavelengths between N fiber in, N fiber out

A 4x4 Non-Reconfigurable

Wavelength Router

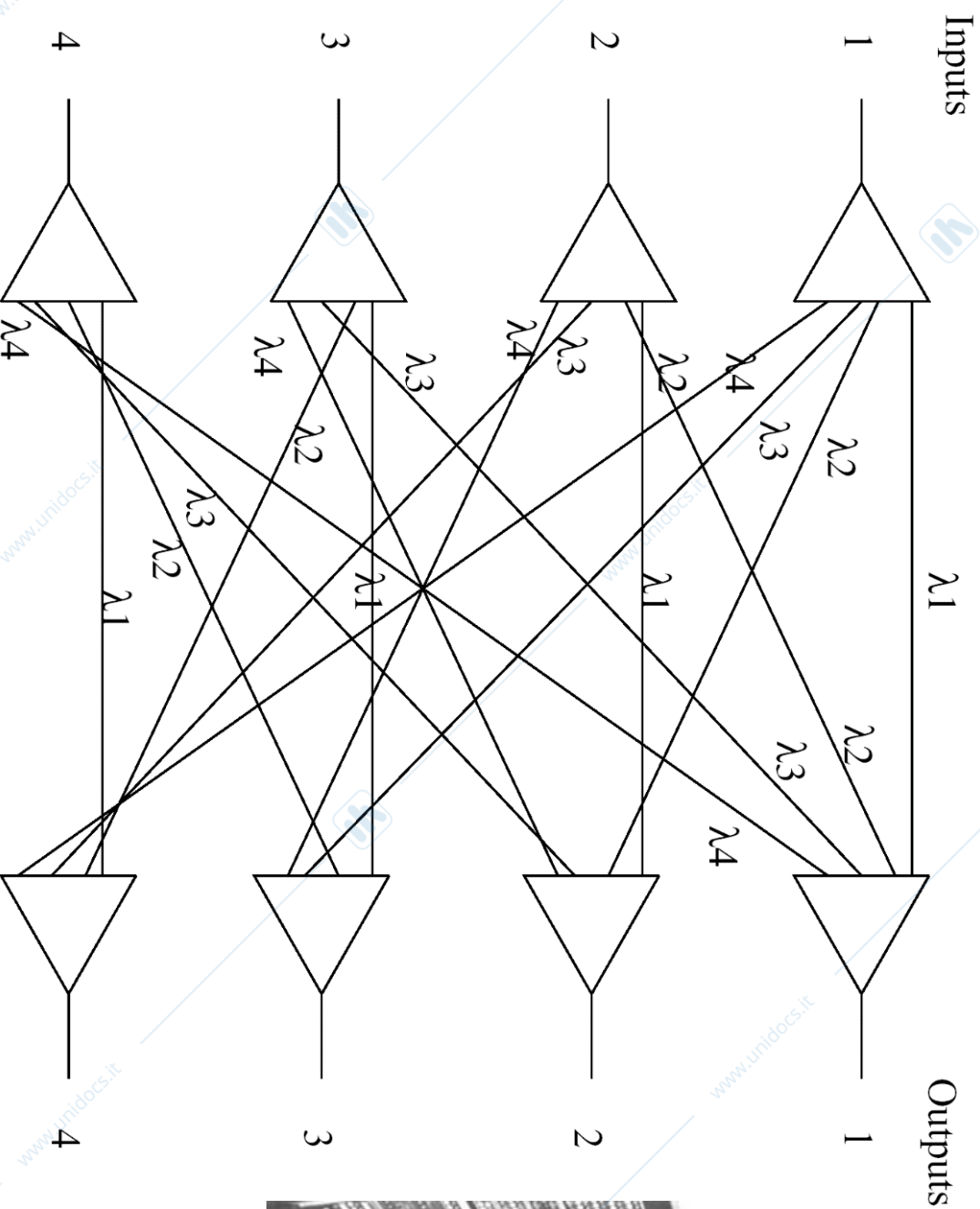

aka «patch panel»
It can work at wavelength
or at fiber level

Reconfigurable Wavelength-Router

(i.e., an OXC!)

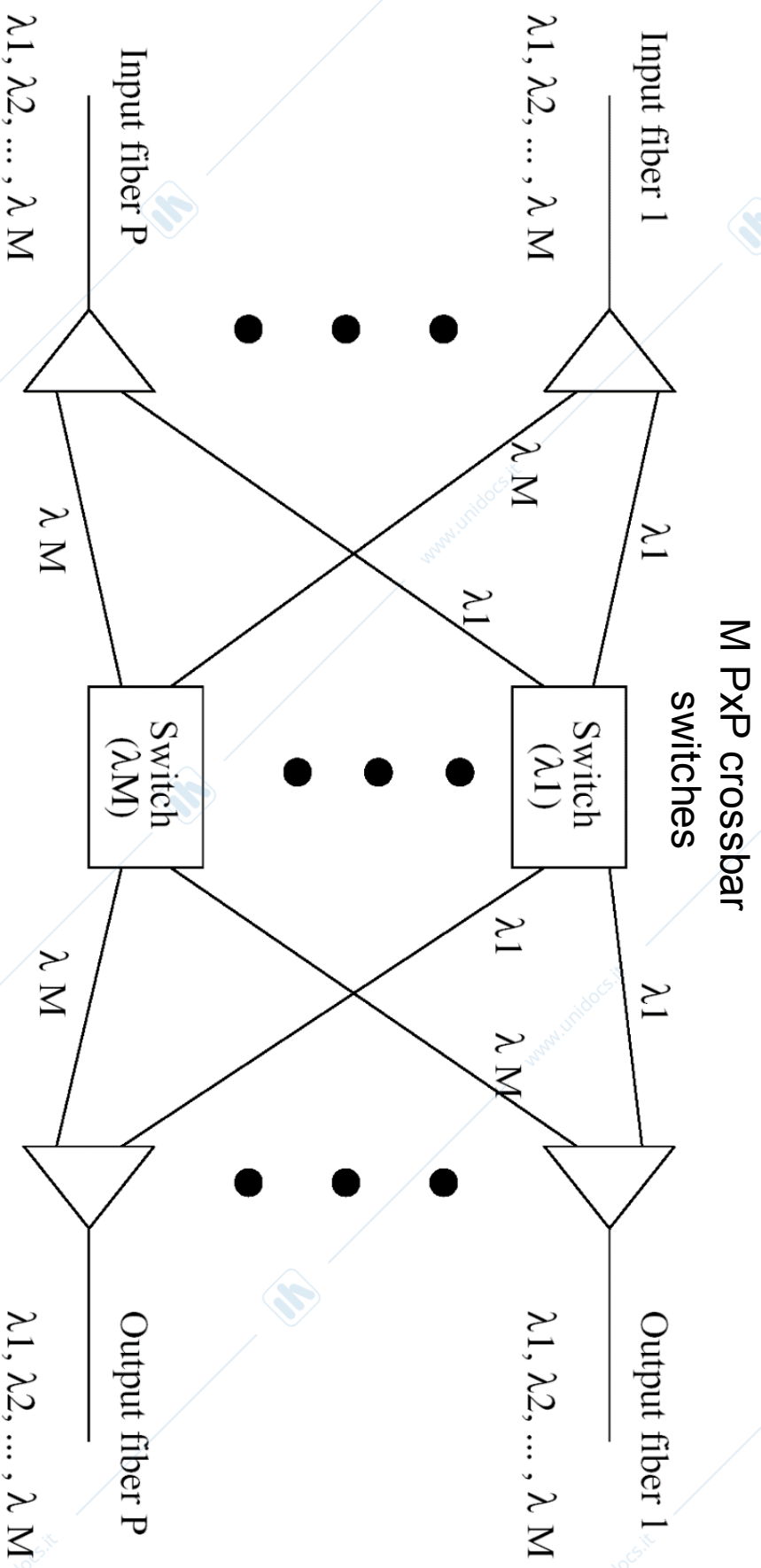

An All-Optical Wavelength-Routed Network

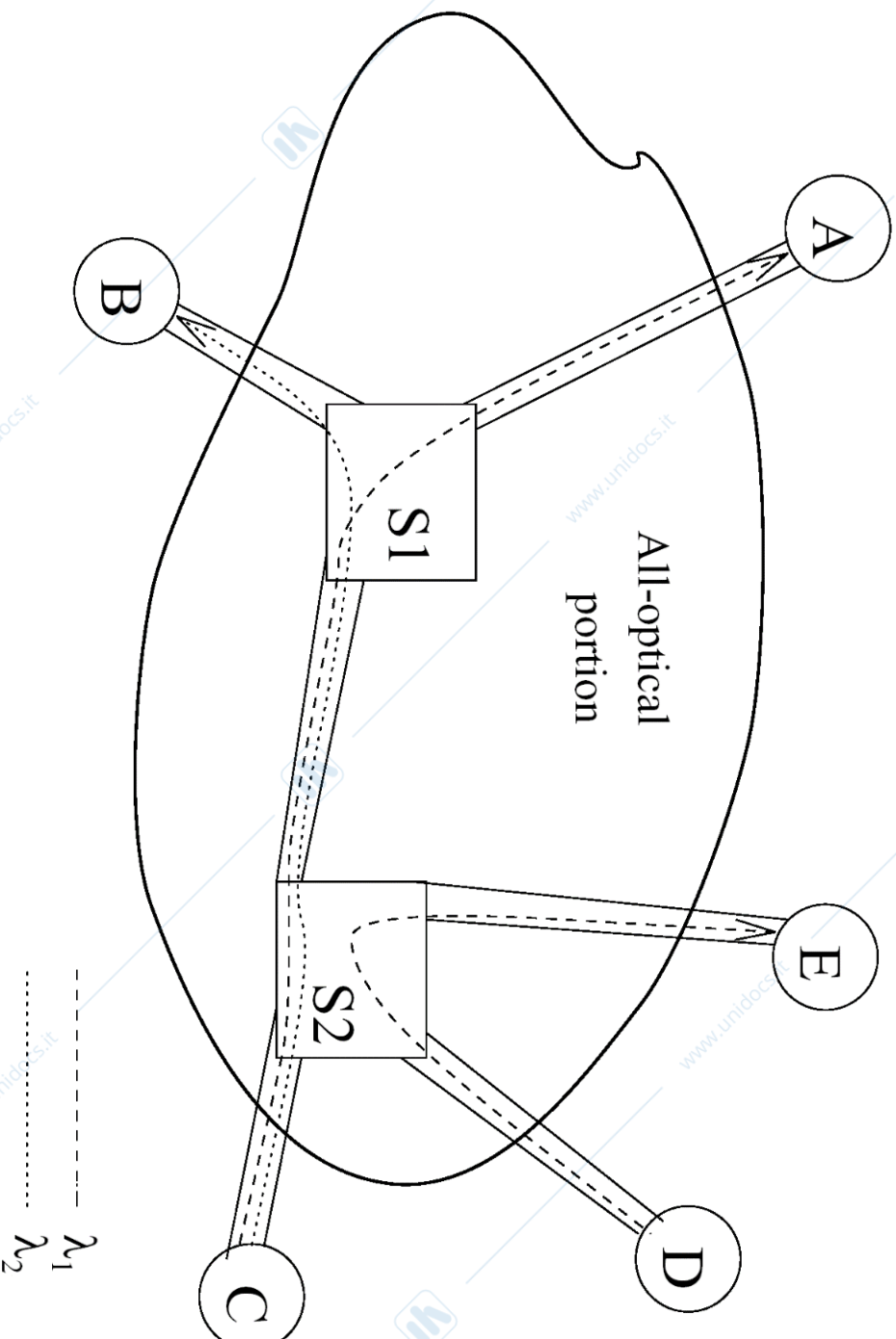

Wavelength-Continuity Constraint in a Wavelength-Routed Network

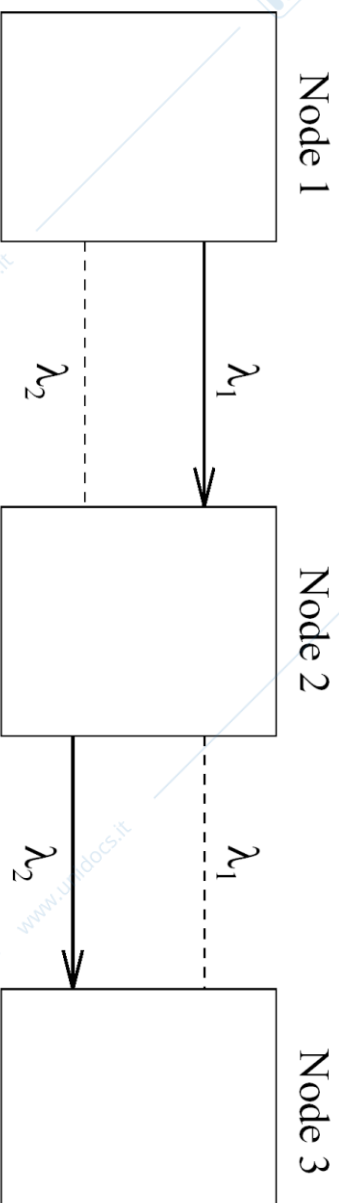

(a) without converter

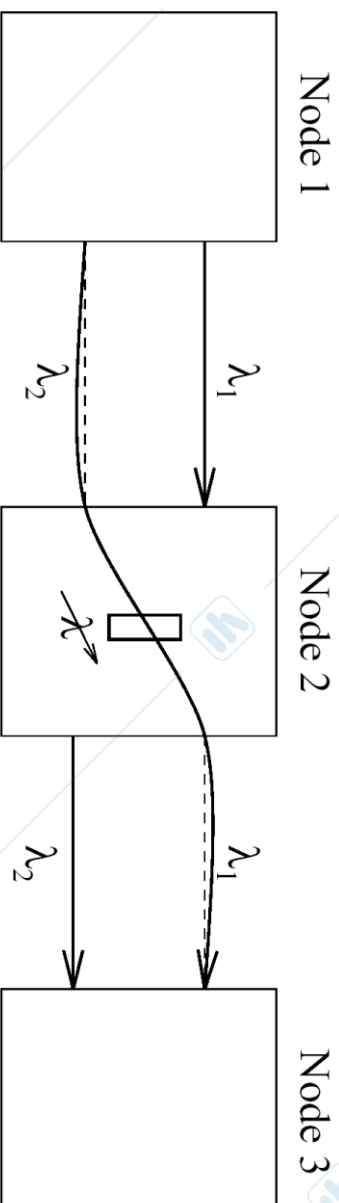

(b) with converter

All-optical Wavelength Converter

The last chimera

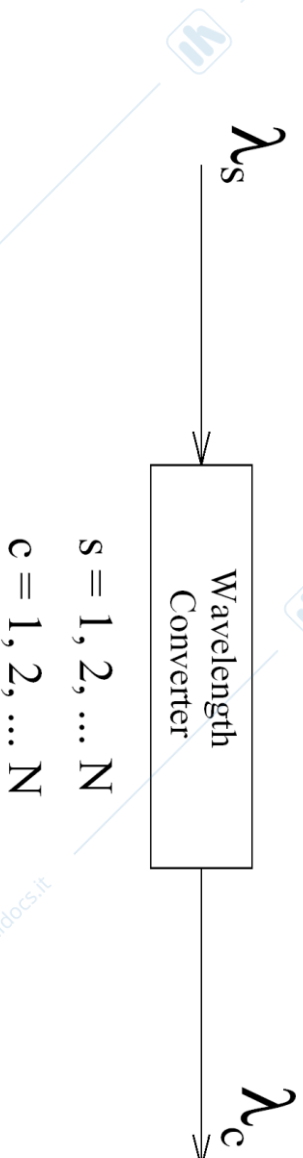

>Functionality and characteristics of an ideal wavelength converter:

- Transparent to bit rates and signal formats
- Fast setup time or output wavelength
- Conversion to both shorter and longer wavelengths
- Moderate input power levels
- Possibility for same input and output wavelengths (i.e., no conversion)
- Polarization insensitivity
- Low-chirp output, high extinction ratio, large SNR
- Simple implementation

END