

CHAPTER 4

INTERFACE ELECTRONIC CIRCUITS

4.1 INPUT CHARACTERISTICS OF INTERFACE CIRCUITS

A system designer is rarely able to connect a sensor directly to processing, monitoring or recording instruments. When a sensor generates an electric signal, that signal often is either too weak, or too noisy, or it contains undesirable components. Besides, the sensor output may be not compatible with the input requirements of a data acquisition system, that is, it may have a wrong format. Therefore, the signal usually has to be *conditioned* before it is fed into a processing device (a load). As its input signal, such a device usually requires either voltage or current. An interface or a signal conditioning circuit has a specific purpose—to bring the signal from the sensor up to the format which is compatible with the load device. Figure 4.1 shows a stimulus that acts on a sensor which is connected to a load through an interface circuit. To do its job effectively, an interface circuit must be a faithful slave of two masters: the sensor's and the load device's. Its input characteristics must be matched to the output characteristics of the sensor and its output must be interface-compatible with the load. This book, however, focuses on the sensors, therefore, below we will discuss only the front stages of the interface circuits.

The input part of an interface circuit may be specified through several standard numbers. These numbers are useful for calculating how accurately the circuit can process the sensor's signal and what is the circuit's contribution to a total error budget?

The *input impedance* shows by how much the circuit loads the sensor. The impedance may be expressed in a complex form as:

$$Z = \frac{V}{I}, \quad (4.1)$$

where V and I are complex notations for the voltage and the current across the input impedance. For example, if the input of a circuit is modeled as a parallel connection of input resistance, R and input capacitance, C , (Fig. 4.2A), the complex input impedance may be represented as

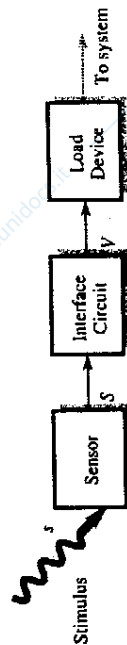

FIGURE 4.1. Interface circuit matches the signal formats of a sensor and a load device.

$$Z = \frac{R}{1 + j\omega RC}, \tag{4.2}$$

where ω is the circular frequency and $j = \sqrt{-1}$ is the imaginary unity. At very low frequencies, a circuit having a relatively low input capacitance and resistance has an input impedance which is almost equal to the input resistance: $Z \approx R$. Relatively low, here it means that the reactive part of the above equation becomes small, i.e., the following holds

$$RC \ll \frac{1}{\omega}. \tag{4.3}$$

Whenever an input impedance of a circuit is considered, the output impedance of the sensor must be taken into account. For example, if the sensor is of a capacitive nature, to define a frequency response of the input stage, sensor's capacitance must be connected in parallel with the circuit's input capacitance. Formula (4.2) suggests that the input impedance is a function of the signal frequency. With an increase in the signal rate of change, the input impedance becomes lower.

Figure 4.2B shows an equivalent circuit for a voltage generating sensor. The circuit is comprised of the sensor output, Z_{out} , and the circuit input, Z_{in} , impedances. The output signal from the sensor is represented by a voltage source, e , which is connected in series with the output impedance. Instead of a voltage source, for some sensors it is more convenient to represent the output signal as outgoing from a current source, which would be connected in parallel with the sensor output

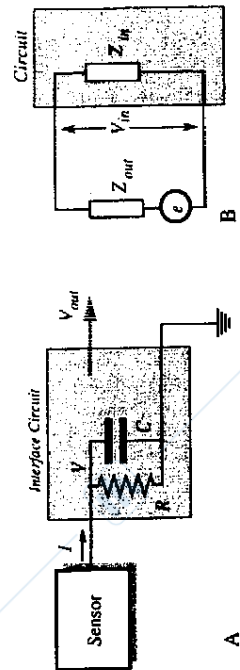

FIGURE 4.2. Complex input impedance of an interface circuit (A) and equivalent circuit of a voltage generating sensor (B).

impedance. Both representations are equivalent to one another, so we will use voltage. Accounting for both impedances, the circuit input voltage, V_{in} is represented as

$$V_{in} = e \frac{Z_{in}}{Z_{in} + Z_{out}}. \tag{4.4}$$

In any particular case, an equivalent circuit of a sensor should be defined. This helps to analyze the frequency response and the phase lag of the sensor-interface combination. For instance, a capacitive detector may be modeled as a pure capacitance connected in parallel with the input impedance. Another example is a piezoelectric sensor which can be represented by a very high resistance (on the order of $10^{11} \Omega$) shunted by a capacitance (on the order of 10 pF).

To illustrate the importance of the input impedance characteristics, let us consider a purely resistive sensor connected to the input impedance as shown in Fig. 4.2. The circuit's input voltage as function of frequency, f , can be expressed by a formula

$$V = \frac{e}{\sqrt{1 + \left(\frac{f}{f_c}\right)^2}}, \tag{4.5}$$

where $f_c = (2\pi RC)^{-1}$ is the corner frequency, that is the frequency where the amplitude drops by 3 dB. If we assume that a 1% accuracy in the amplitude detection is required, then we can calculate the maximum stimulus frequency which can be processed by the circuit:

$$f_{max} \approx 0.14 f_c, \tag{4.6}$$

or $f_c \approx 7 f_{max}$, that is, the impedance must be selected in such a way as to assure a sufficiently high corner frequency. For example, if the stimulus' highest frequency is 100 Hz, the corner frequency must be selected at least at 700 Hz. In practice, f_c is selected even higher, because of the additional frequency limitations in the subsequent circuits.

One should not overlook a speed response of the front stage of the interface circuit. Operational amplifiers, which are the most often used building blocks of interface circuits, usually have limited frequency bandwidths. There are the so-called programmable operational amplifiers which allow the user to control (to program) the bias current and, therefore, the first stage frequency response. The higher the current, the faster would be the response.

Figure 4.3 is a more detailed equivalent circuit of the input properties of a passive electronic interface circuit,¹ for instance, an amplifier or an A/D converter. The circuit is characterized by the input impedance Z_{in} and several generators. They represent voltages and currents which are generated by the circuit itself. These

¹Here the word passive means that the circuit does not generate any excitation signal.

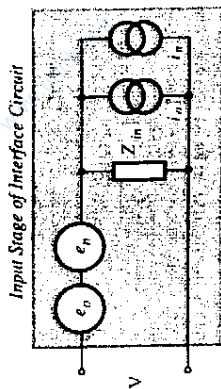

FIGURE 4.3. Equivalent circuit of electrical noise sources at an input stage.

signals are spurious and may pose substantial problems if not handled properly. All these signals are temperature dependent.

Voltage e_o is called the input *offset voltage*. If the input terminals of the circuit are shorted together, that voltage would simulate a presence of an input dc signal having a value of e_o . It should be noted that the offset voltage source is connected in series with the input and its resulting error is independent of the output impedance of the sensor.

The input *bias current* i_o is also internally generated by the circuit. Its value is quite high for many bipolar transistors, much smaller for the JFETs, and even more lower for the CMOS circuits. This current may present a serious problem when a circuit or a sensor employs high impedance components. The bias current passes through the input impedance of the circuit and the output impedance of the sensor, resulting in a spurious voltage drop. This voltage may be of a significant magnitude. For instance, if a piezoelectric sensor is connected to a circuit having an input resistance of $1\text{ G}\Omega$ ($10^9\ \Omega$) and the input bias current of 1 nA (10^{-9} A), the voltage drop at the input becomes equal to $1\text{ G}\Omega \cdot 1\text{ nA} = 1\text{ V}$ —a very high value indeed. In contrast to the offset voltage, the bias current resulting error is proportional to the output impedance of the sensor. This error is negligibly small for the sensors having low output resistances. For instance, an inductive detector is not sensitive to a magnitude or variations in the bias current.

A circuit board *leakage current* may be a source of errors while working with high impedance circuits. This current may be the result of lower surface resistance in the printed circuit board. Figure 4.4A shows that a power supply bus and the board resistance, R_L , may cause leakage current, i_L , through the sensor's output impedance. If the sensor is capacitive, its output capacitance will be very quickly charged by the leakage current. This will not only cause an error, but may even lead to the sensor's destruction.

There are several techniques known to minimize the board leakage current effect. One is a careful board layout to keep higher voltage conductors away from the high impedance components. A leakage through the board thickness in multilayer boards should not be overlooked. Another method is electrical guarding, which is an old trick. The so-called driven shield is also highly effective. Here, the input circuit is

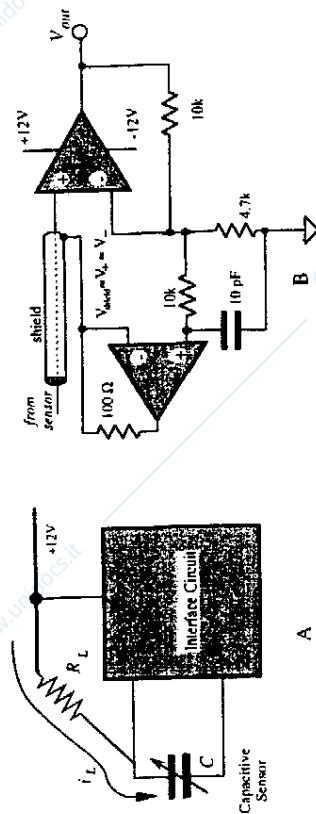

FIGURE 4.4. Circuit board leakage affects input stage (A); driven shield of the input stage (B).

surrounded by a conductive trace that is connected to a low impedance point at the same potential as the input. The guard absorbs the leakage from other points on the board, drastically reducing currents that may reach the input terminal. To be completely effective, there should be guard rings on both sides of the printed circuit board. As an example, an amplifier is shown with a guard ring, driven by a relatively low impedance of the amplifier's inverting input.

It is highly advisable to locate the high impedance interface circuits as close as possible to the sensors. However, sometimes connecting lines can not be avoided. Coaxial shielded cables with good isolation are recommended [1]. Polyethylene or virgin (not reconstructed) Teflon[®] is best for the critical applications. In addition to potential insulation problems, even short cable runs can reduce bandwidth unacceptably with high source resistances. These problems can be largely avoided by bootstrapping the cable's shield. Figure 4.4B shows a voltage follower connected to the inverting input of an amplifier. The follower drives the shield of the cable, thus reducing the cable capacitance, the leakage and spurious voltages resulting from cable flexing. A small capacitance at the follower's noninverting input improves its stability.

4.2 AMPLIFIERS

Most passive sensors produce weak output signals. Magnitudes of these signals may be on the order of millivolts (mV) or picoamperes (pA). On the other hand, standard electronic data processors, such as A/D converters, frequency modulators, data recorders, etc. require input signals of sizable magnitudes—on the order of volts (V) and milliampères (mA). Therefore, an amplification of the sensor output signals has to be made with a voltage gain up to 1000 and a current gain up to 1 million. Amplification is a part of a signal conditioning. There are several standard configurations of amplifiers which might be useful for the amplifying signals from various

sensors. These amplifiers may be built of discrete components, such as transistors, diodes, resistors, capacitors, and inductors.

4.2.1 Operational Amplifiers

Nowadays, one of the principle building blocks for the amplifiers is the so-called *operational amplifier* or OPAM, which is either an integrated (monolithic) or hybrid (a combination of monolithic and discrete parts) circuit. An integrated OPAM may contain hundreds of transistors, as well as resistors and capacitors. An analog circuit designer, by arranging around the OPAM discrete components (resistors, capacitors, inductors, etc.), may create an infinite number of useful circuits—not only the amplifiers; but many others circuits as well. Below, we will describe some circuits which are often used in conjunction with various sensors.

As a building block, a good operational amplifier has the following properties (a schematic representation of OPAM is shown in Fig. 4.5):

- Two inputs: one is inverting (—) and the other is noninverting (+).
- A high input resistance (on the order of hundreds of MΩ or even GΩ).
- A low output resistance (a fraction of Ω).
- A low input offset voltage e_o (few mV or even μV).
- A low input bias current i_o (few pA or even less).
- A very high open loop gain (on the orders of 10^4 to 10^6) A_{OL} . That is, the OPAM must be able to magnify (amplify) a voltage difference V_{in} , between its two inputs by a factor of A_{OL} .
- A high common mode rejection ratio (CMRR). That is, the amplifier suppresses the inphase equal magnitude input signals (common-mode signals) V_{CM} applied to its both inputs.
- Low intrinsic noise.
- A broad operating frequency range.

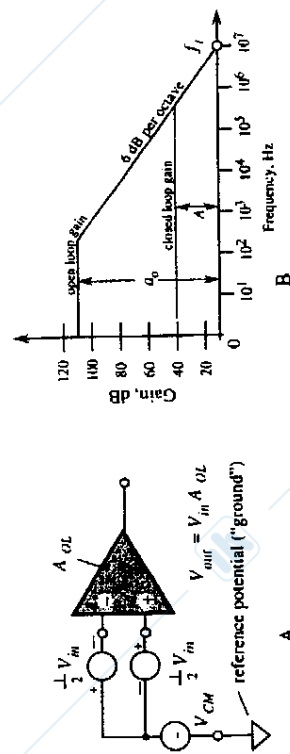

FIGURE 4.5. General symbol of an operational amplifier (A) and gain/frequency characteristic of an OPAM (B).

A low sensitivity to variations in the power supply voltage.
A high environmental stability of its own characteristics.

For the detailed information and the application guidance the user should refer to data books published by the respective manufacturers. Such books usually contain selection guides for the every important feature of an OPAM. For instance, OPAMs are grouped by such criteria as low offset voltages, low bias currents, low noise, broad bandwidth, etc.

Figure 4.5A depicts an operational amplifier without any feedback components. Therefore, it operates under the so-called *open-loop* conditions. An open loop gain, A_{OL} , of an OPAM is not constant over the frequency range. It may be approximated by a graph of Fig. 4.5B. The A_{OL} changes with the load resistance, temperature and the power supply fluctuations. Many amplifiers have an open loop gain temperature coefficient on the order of 0.2 to 1%/°C and the power supply gain sensitivity on the order of 1%/%. An OPAM is very rarely used with an open loop (without the feedback components) because the high open-loop gain may result in a circuit instability, a strong temperature drift, noise, etc. For instance, if the open-loop gain is 10^5 , the input voltage drift of $10 \mu V$ (10 microvolts) would cause the output drifts by about 1 V.

The ability of an OPAM to amplify small magnitude high frequency signals is specified by the gain-bandwidth product (GBW) which is equal to the frequency f_1 where the amplifier gain becomes equal to unity. In other words, above the f_1 frequency, the amplifier can not amplify. Figure 4.6A depicts a non-inverting amplifier where resistors R_1 and R_2 define the feedback loop. The resulting gain $A = 1 + R_2/R_1$ is a closed-loop gain. It may be considered constant over a much broader frequency range (see Fig. 4.5B), however, f_1 is the frequency limiting factor regardless of the feedback. A linearity, gain stability, the output impedance, and gain accuracy are all improved, by the amount of feedback. As a general rule for moderate accuracy, the open loop gain of an OPAM should be at least 100 times greater than the closed loop gain at the highest frequency of interest. For even higher accuracy, the ratio of the open and closed loop gains should be 1000 or more.

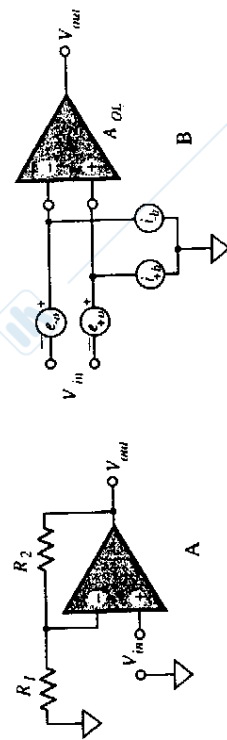

FIGURE 4.6. Noninverting amplifier (A); offset voltages and bias currents in an operational amplifier are represented by generators connected to its inputs (B).

A typical data sheet for an OPAM specifies the bias and offset voltages. Due to limitations in manufacturing technologies, any OPAM acts not only as a pure amplifier, but as a generator of voltages and currents which may be related to its input (Fig. 4.3). Since these spurious signals are virtually applied to the input terminals, they are amplified along with the useful signals.

Because of offset voltages and bias currents, an interface circuit does not produce zero output when zero input signal is applied. In dc-coupled circuits, these undesirable input signals may be indistinguishable from the useful signal. If the input offset voltage is still too large for the desired accuracy, it can be trimmed out either directly at the amplifier (if the amplifier has dedicated trimming terminals) or in the independent offset compensation circuit.

4.2.2 Voltage Follower

A voltage follower (Fig. 4.7) is an electronic circuit that provides impedance conversion from a high to low level. A typical follower has high input impedance (the high input resistance and the low input capacitance) and low output resistance (the output capacitance makes no difference). A follower has a voltage gain very close to unity (typically, 0.999) and a high current gain. In essence, it is a current amplifier and impedance converter. That is, its high input impedance and low output impedance make it indispensable for the interfacing between many sensors and signal processing devices.

A follower, when connected to a sensor, makes very little effect on the latter's performance, thus providing a buffering function between the sensor and the load. When designing a follower, these tips might be useful:

- For the current generating sensors, the input bias current of the follower must be at least 100 times smaller than the sensor's current.
- The input offset voltage must be either trimable or smaller than the required LSB.
- The temperature coefficient of the bias current and the offset voltage should not result in errors of more than 1 LSB over an entire temperature range.

An application engineer should be concerned with, the output offset voltage, which can be derived from formula:

$$V_o = A(e_o + i_o R_{eq}) \quad (4.7)$$



FIGURE 4.7. Voltage follower with an operational amplifier.

where R_{eq} is the equivalent resistance at the input (a combination of the sensor's output resistance and the input resistance of the amplifier), e_o is the input offset voltage and i_o is the input bias current. The offset is temperature dependent. In circuits where the amplifier has high gain, the output voltage offset may be a source of substantial error. There are several ways to handle this difficulty. Among them is selecting an amplifier with low bias current, high input resistance and low offset voltage. Chopper stabilized amplifiers are especially efficient for reduction of offset voltages.

4.2.3 Monopolar Amplifiers

A monopolar amplifier is similar to a voltage follower, except that its gain may be either higher or lower than unity. Thus, it may serve as both voltage and current amplifier (or scaling circuit). A practical circuit is shown in Fig. 4.6A. Resistors R_1 and R_2 define gain of the amplifier:

$$A = 1 + \frac{R_2}{R_1} \quad (4.8)$$

It can be seen that the minimum gain is 1 (when $R_1 = \infty$ or $R_2 = 0$) when the amplifier becomes a voltage follower. A capacitor in parallel with R_2 may be used to limit the bandwidth, which is often important for noise reduction. A bandwidth of such a circuit at 3 dB level may be estimated from a simple formula.

$$f_u = \frac{0.159}{R_2 C} \quad [\text{Hz}] \quad (4.9)$$

While the circuit of Fig. 4.6A shows a noninverting amplifier, Fig. 4.7B depicts an inverting amplifier. Its gain is defined as $A = R_2/R_1$, where the balance resistor² is $R_3 = R_1 \parallel R_2$. It should be noted, however, that such an inverting amplifier has a relatively low input resistance equal to R_1 . This may result in the excessive loading of the sensor. The solution would be to use instead either a noninverting amplifier, or to employ a voltage follower between the sensor and the inverting amplifier.

4.2.4 Instrumentational Amplifiers

An instrumentational amplifier (IA) has two inputs and one output. It is distinguished from an operational amplifier by its finite gain (which is usually no more than 100) and the availability of both inputs for connecting to the signal sources. The latter feature means that all necessary feedback components are connected to other parts of the instrumentational amplifier, rather than to its noninverting and inverting inputs. The main function of the IA is to produce an output signal which is proportional to the difference in voltages between its two inputs:

²Resistor R_3 may not be required if bias current is small enough not to cause significant errors.

$$V_{out} = A(V_+ - V_-) = A \Delta V, \quad (4.10)$$

where V_+ and V_- are the input voltages at noninverting and inverting inputs respectively, and A is the gain. An instrumental amplifier can be either built from an OPAM, in a monolithic, or hybrid forms. It is important to assure high input resistances for both inputs, so that the amplifier can be used in a true differential mode. A differential input of the amplifier is very important for rejection of common mode interferences having an additive nature (see Sec. 4.9).

While several monolithic instrumental amplifiers are presently available, quite often discrete component circuits prove to be more cost-effective and often more efficient. A basic circuit of IA is shown in Fig. 4.8. The voltage across R_a is forced to become equal to the input voltage difference ΔV . This sets the current through that resistor equal to $i = \Delta V/R_a$. The output voltages from the U_1 and U_2 OPAMs are equal to one another in amplitudes and opposite in the phases. Hence, the front stage (U_1 and U_2) has a differential input and a differential output configuration. The second stage (U_3) converts the differential output into a unipolar output and provides an additional gain. The overall gain of the IA is

$$A = \left(1 + \frac{2R}{R_a}\right) \frac{R_3}{R_2}. \quad (4.11)$$

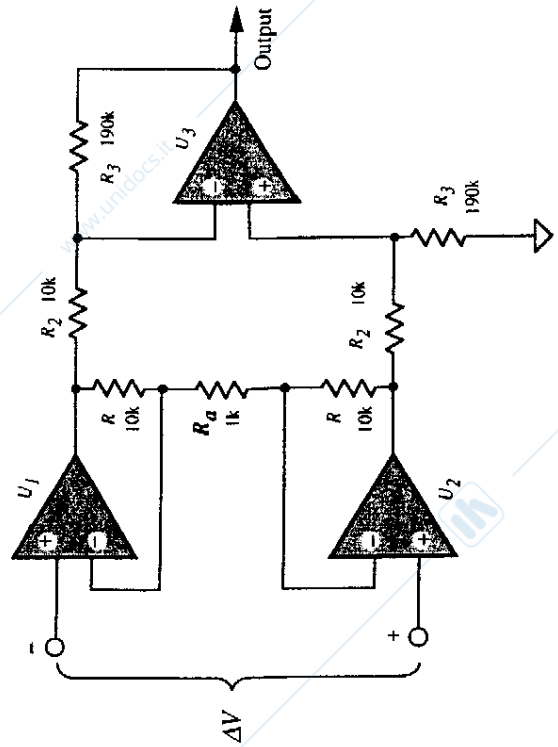

FIGURE 4.8. Instrumental amplifier with three operational amplifiers and matched resistors.

The common mode rejection ratio (CMRR) depends on matching of resistors within the corresponding group (R_1 , R_2 , and R_3). As a rule of thumb, 1% resistors yield CMRR no better than 100, while for 0.1% CMRR is no better than 1000.

A good and cost-effective instrumental amplifier can be built of two identical operational amplifiers and several precision resistors (Fig. 4.9A). The circuit uses the FET-input OPAMs to provide lower noise and lower input bias currents. The U_1 acts as a noninverting amplifier and U_2 is the inverting one. Each input has a high impedance and can be directly interfaced with a sensor. A feedback from each amplifier forces voltage across the gain-setting resistor R_a to become equal to ΔV . The gain of the amplifier is equal to

$$A \approx 2 \left(1 + \frac{R}{R_a}\right) \quad (4.12)$$

Hence, gain may vary from 2 (R_a is omitted) to a potentially open loop gain ($R_a = 0$). With the components whose values are shown in Fig. 4.9, the gain is $A = 100$. It should be remembered, however, that the input offset voltage will be amplified with the same gain. The CMRR primarily depends on matching values of resistors R . At very low frequencies, it is the reciprocal of the net fractional resistor mismatch, i.e., $CMRR = 10,000$ (-80 dB) for a 0.01% mismatch. At higher frequencies, the impedance mismatch must be considered, rather than the resistor mismatch. To balance the impedances, a trimpot and a capacitor C_1 may be used.

When cost is a really limiting factor and no high quality dc characteristics are required, a very simple IA can be designed with just one operational amplifier and two resistors (Fig. 4.9B). The feedback resistor R_a is connected to the null-balance

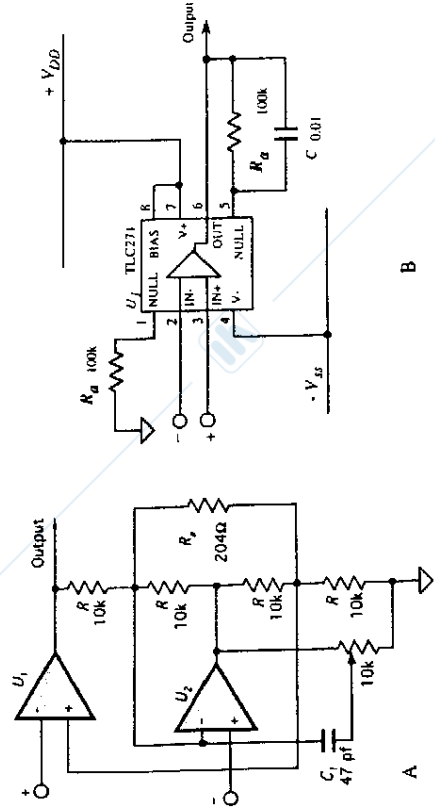

FIGURE 4.9. A: Instrumental amplifier with two operational amplifiers; B: Low cost ac instrumental amplifier with one operational amplifier.

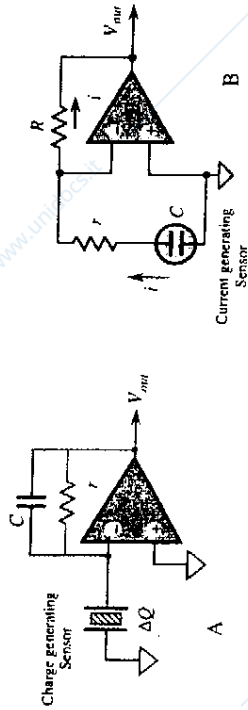

FIGURE 4.10. Charge-to-voltage (A) and current-to-voltage (B) converters.

terminal of the OPAM which is the output of the front stage of the monolithic circuit. The amount of the feedback through R_a depends on the actual circuit of an OPAM and somewhat varies from part to part. For the TLC271 operational amplifier (Texas Instruments), gain of the circuit may be found from

$$A \approx 1 + \frac{R_a}{2 \text{ k}\Omega} \quad (R_a \text{ is in k}\Omega), \quad (4.13)$$

which for values indicated in Fig. 4.10B gives gain of about 50.

4.2.5 Charge Amplifiers

Charge amplifiers (CA) is a very special class of circuits which must have extremely low bias currents. These amplifiers are employed to convert to voltage signals from capacitive sensors, quantum detectors, pyroelectric sensors, and other devices which generate very low charges (on the order of pico-coulombs, pC) or currents (on the order of pico-amperes). A basic circuit of a charge-to-voltage converter is shown in Fig. 4.10A. A capacitor, C , is connected into a feedback network of an OPAM. Its leakage resistance r must be substantially larger than the impedance of the capacitor at the lowest operating frequency. A transfer function of the converter is:

$$V_{out} = - \frac{\Delta Q}{C}. \quad (4.14)$$

Special hybrid charge sensitive preamplifiers are available for precision applications. One example is DN630 from Dawn Electronics, Inc.³ The amplifier can operate with sources of less than 1 pF capacitance. An internally connected 1 pF capacitor sets the gain of the amplifier to 1 volt per 1 pC (picocoulomb) sensitivity.

³Carson City, Nevada. Tel. (702) 882-7721.

The gain can be reduced by connecting one or a combination of the internal capacitor array to the input of the amplifier. It features low noise and has less than 5 ns rise and fall times.

Many sensors can be modeled by capacitors. Some capacitive sensors are active, that is, they require an excitation signal. Examples are the capacitive force and pressure transducers and humidity detectors. Other capacitive sensors are passive, that is they directly convert a stimulus into an electric current. Examples are the piezoelectric and pyroelectric detectors. Ohm's law suggests that to convert an electric current into voltage, current should pass through an appropriate resistor and the voltage drop across that resistor is proportional to the magnitude of the current. Fig. 4.10B shows a basic current-to-voltage converter where the capacitive current generating sensor is connected to the inverting input of an OPAM which serves as a virtual ground. That is, voltage at the input is almost equal to that at the non-inverting input which is grounded. The sensor operates at zero voltage across its terminals and its current is represented by the output voltage of the OPAM:

$$V_{out} = -iR. \quad (4.15)$$

Resistor, $r \ll R$ is generally required for the circuit stability. At high frequencies, the OPAM would operate near the open loop gain which may result in oscillations. The advantage of the virtual ground is that the output signal does not depend on the sensor's capacitance. The circuit produces voltage whose phase is shifted by 180° with respect to the current. A noninverting circuit shown in Fig. 4.11A can convert and amplify the signal, however, its speed response depends on both the sensor's capacitance and the converting resistor. Thus, the response to a step function in a time domain can be described by:

$$V_{out} = iR_b \left(1 + \frac{R_2}{R_1} \right) (1 - e^{-t/rC}). \quad (4.16)$$

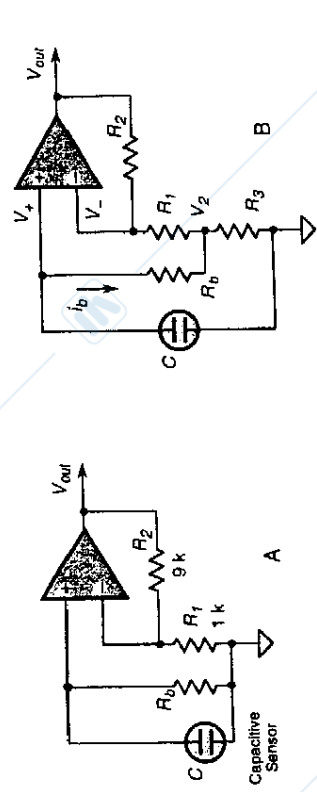

FIGURE 4.11. Noninverting current-to-voltage converter (A) and resistance multiplier (B).

When converting currents from such sensors as piezo and pyroelectrics, the resistor R_b (R in circuit 4.10B) may be required on the order of tens or even hundreds of gigohms. In many cases resistors of such high values may be not available or impractical to use due to poor environmental stability. A high ohmic resistor can be simulated by a circuit which is known as a resistance multiplier. It is implemented by adding a positive feedback around the amplifier. Figure 4.11B shows that R_1 and R_3 form a resistive divider. Due to a high open loop gain of the OPAM, voltages at noninverting and inverting inputs are almost equal to one another: $V_+ \approx V_-$. As a result, voltage, V_2 , at the divider is

$$V_2 = V_- \frac{R_3}{R_1 + R_3} \approx V_+ \frac{R_3}{R_1 + R_3}, \quad (4.17)$$

and current through the resistor is defined through the voltage drop:

$$i_b = \frac{\Delta V}{R_b} = \frac{V_+ - V_2}{R_b} = \frac{V_+}{R_b} \frac{R_1}{R_1 + R_3}. \quad (4.18)$$

From this equation, the input voltage can be found as a function of the input current and the resistive network:

$$V_+ = i_b R_b \left(1 + \frac{R_3}{R_1} \right). \quad (4.19)$$

It is seen that the resistor R_b is multiplied by a factor of $(1 + R_3/R_1)$. For example, if the highest resistor you have is 10 Mohm, by selecting the multiplication factor of say 5 you get a virtual resistance of 50 MOhms. Resistance multiplication, while being a powerful trick should be used with some caution. Specifically, noise, bias current, and offset voltage—all of them are also multiplied by the same factor $(1 + R_3/R_1)$, which may be undesirable in some applications. Further, since the network forms a positive feedback, it may cause circuit instability. Therefore, in practical circuits, a resistance multiplication should be limited to a factor of 10.

4.7 BRIDGE CIRCUITS

Wheatstone bridge circuits are popular and very effective implementations of the ratiometric technique. A basic circuit is shown in Fig. 4.40. Impedances Z may be either active or reactive, that is they may be either simple resistances, like in piezo-resistive gauges, or capacitors, or inductors. For the resistor, the impedance is R , for the ideal capacitor, the magnitude of its impedance is equal to $1/2\pi fC$ and for the inductor, it is $2\pi fL$, where f is the frequency of the current passing through the element. The bridge output voltage is represented by:

$$V_{\text{out}} = \left(\frac{Z_1}{Z_1 + Z_2} - \frac{Z_3}{Z_3 + Z_4} \right) V_{\text{ref}} \quad (4.55)$$

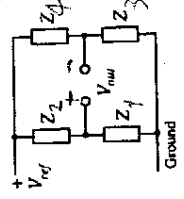

FIGURE 4.40. General circuit of Wheatstone bridge.

The bridge is considered to be in a balanced state when the following condition is met:

$$\frac{Z_1}{Z_2} = \frac{Z_3}{Z_4} \quad (4.56)$$

Under the balanced condition, the output voltage is zero. When at least one impedance changes, the bridge becomes imbalanced and the output voltage goes either in a positive or negative direction, depending on the direction of the impedance change. To determine the bridge sensitivity with respect to each impedance (calibration constant) partial derivatives may be obtained from Eq. (4.55):

$$\begin{aligned} \frac{\partial V_{out}}{\partial Z_1} &= \frac{Z_2}{(Z_1 + Z_2)^2} V_{ref} \\ \frac{\partial V_{out}}{\partial Z_2} &= -\frac{Z_1}{(Z_1 + Z_2)^2} V_{ref} \\ \frac{\partial V_{out}}{\partial Z_3} &= -\frac{Z_4}{(Z_3 + Z_4)^2} V_{ref} \\ \frac{\partial V_{out}}{\partial Z_4} &= \frac{Z_3}{(Z_3 + Z_4)^2} V_{ref}. \end{aligned} \quad (4.57)$$

By summing these equations, we obtain the bridge sensitivity:

$$\frac{\delta V_{out}}{V_{ref}} = \frac{Z_2 \delta Z_1 - Z_1 \delta Z_2}{(Z_1 + Z_2)^2} - \frac{Z_4 \delta Z_3 - Z_3 \delta Z_4}{(Z_3 + Z_4)^2} \quad (4.58)$$

A closer examination of Eq. (4.58) shows that only the adjacent pairs of impedances (i.e., Z_1 and Z_2 , Z_3 and Z_4) have to be identical in order to achieve the ratio metric compensation (such as the temperature stability, drift, etc.). It should be noted that impedances in the balanced bridge do not have to be equal, as long as a balance of the ratio (4.56) is satisfied. In many practical circuits, only one impedance is used as a sensor, thus for Z_1 , the bridge sensitivity becomes:

$$\frac{\delta V_{out}}{V_{ref}} = \frac{\delta Z_1}{4Z_1} \quad (4.59)$$

The resistive bridge circuits are commonly used with strain gauges, piezoresistive pressure transducers, thermistor thermometers, and other sensors when immunity against environmental factors is required. Similar arrangements are used with the capacitive and magnetic sensors for measuring force, displacement, moisture, etc.

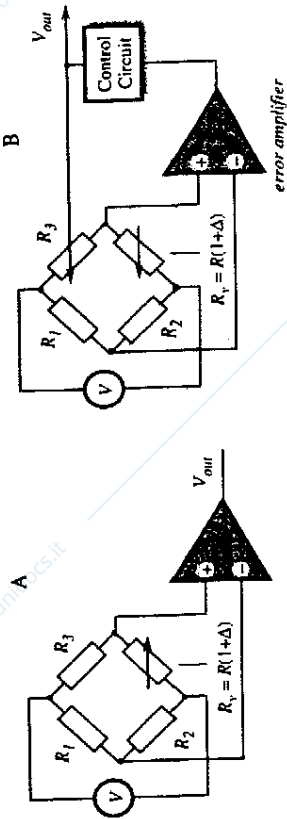

FIGURE 4.41. Two methods of using a bridge circuit. A: disbalanced bridge and B: balanced bridge with a feedback control.

4.7.1 Disbalanced Bridge

A basic Wheatstone bridge circuit (Fig. 4.41A) generally operates with a disbalanced bridge. This is called the *deflection* method of measurement. It is based on detecting the voltage across the bridge diagonal. The bridge output voltage is a nonlinear function of a disbalance Δ , however, for small changes ($\Delta < 0.05$) it may be considered quasi-linear. The bridge maximum sensitivity is obtained when $R_1 = R_2$ and $R_3 = R$. When $R_1 \gg R_2$ or $R_2 \gg R_1$, the bridge output voltage is decreased. Assuming that $k = R_1/R_2$, the bridge sensitivity may be expressed as:

$$\alpha = \frac{V}{R} \frac{k}{(k+1)^2} \quad (4.60)$$

A normalized graph calculated according to this equation is shown in Fig. 4.42. It indicates that the maximum sensitivity is achieved at $k = 1$, however, the sensitivity drops relatively little for the range where $0.5 < k < 2$. If the bridge is fed by a current source, rather than a voltage source, its output voltage for small Δ and a single variable component is represented by:

$$V_{out} \approx I \frac{k\Delta}{2(k+1)} \quad (4.61)$$

where I is the excitation current.

4.7.2 Null-Balanced Bridge

Another method of using a bridge circuit is called a *null-balance*. The method overcomes the limitation of small changes (Δ) in the bridge arm to achieve a good linearity. The null-balance essentially requires that the bridge is always maintained at the balanced state. To satisfy the requirement for a bridge balance (4.56), another arm of the bridge should vary along with the arm which is used as a sensor. Figure

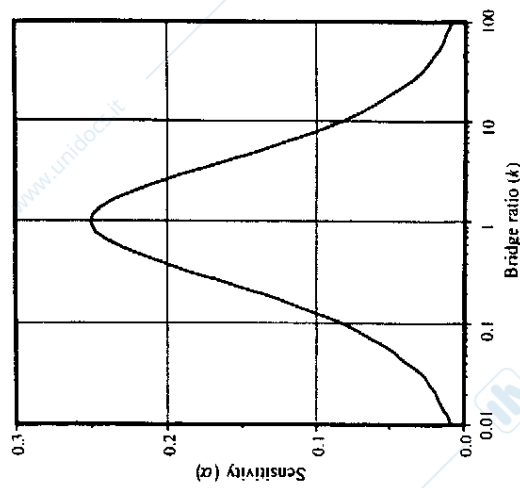

FIGURE 4.42. Sensitivity of a disbalanced bridge as a function of impedance ratio.

4.41B illustrates this concept. A control circuit modifies the value of R_3 on the command from the error amplifier. The output voltage may be obtained from the control signal of the balancing arm R_3 . For example, both R_1 and R_3 may be photoresistors. The R_3 -photoresistor could be interfaced with a light emitting diode (LED) which is controlled by the error amplifier. Current through the LED becomes a measure of resistance R_1 , and, subsequently, of the light intensity detected by the sensor.