

Oscilloscopio: Caratteristiche e uso

*Tektronix founders,
Jack Murdock and
Howard Vollum,
with an oscilloscope
from the 1950s.*



Politecnico di Milano, 1 Dicembre 2020, Luigi Soffientini

What is an oscilloscope?



- Oscilloscopes **convert** electrical input signals into a visible trace on a screen - i.e. they convert electricity into light.
- Oscilloscopes dynamically **graph** time-varying electrical signals in two dimensions (typically voltage vs. time).
- Oscilloscopes are used by engineers and technicians to test, verify, and debug electronic designs.
- Oscilloscopes will be the primary instrument that you will use in your EE/Physics labs to test assigned experiments.

Terms of Endearment (what they are called)

- Scope – Most commonly used terminology
- DSO – Digital Storage Oscilloscope
- ART – Analog Real Time.
- CRO – Cathode Ray Oscilloscope (pronounced “crow”). Even though most scopes no longer utilize cathode ray tubes to display waveforms, Aussies and Kiwis still affectionately refer to them as their CROs.
- MSO – Mixed Signal Oscilloscope (includes logic analyzer channels of acquisition)



10 Keys on How to Select Your Scope

“Banner” Specifications to Consider

- Bandwidth
- Sample Rate
- Memory Depth
- Number of Channels
- Waveform UpdateRate

Other Important Factors to Consider

- Triggering
- Serial Bus Applications
- Measurements & Analysis
- Connectivity & Documentation
- Probing

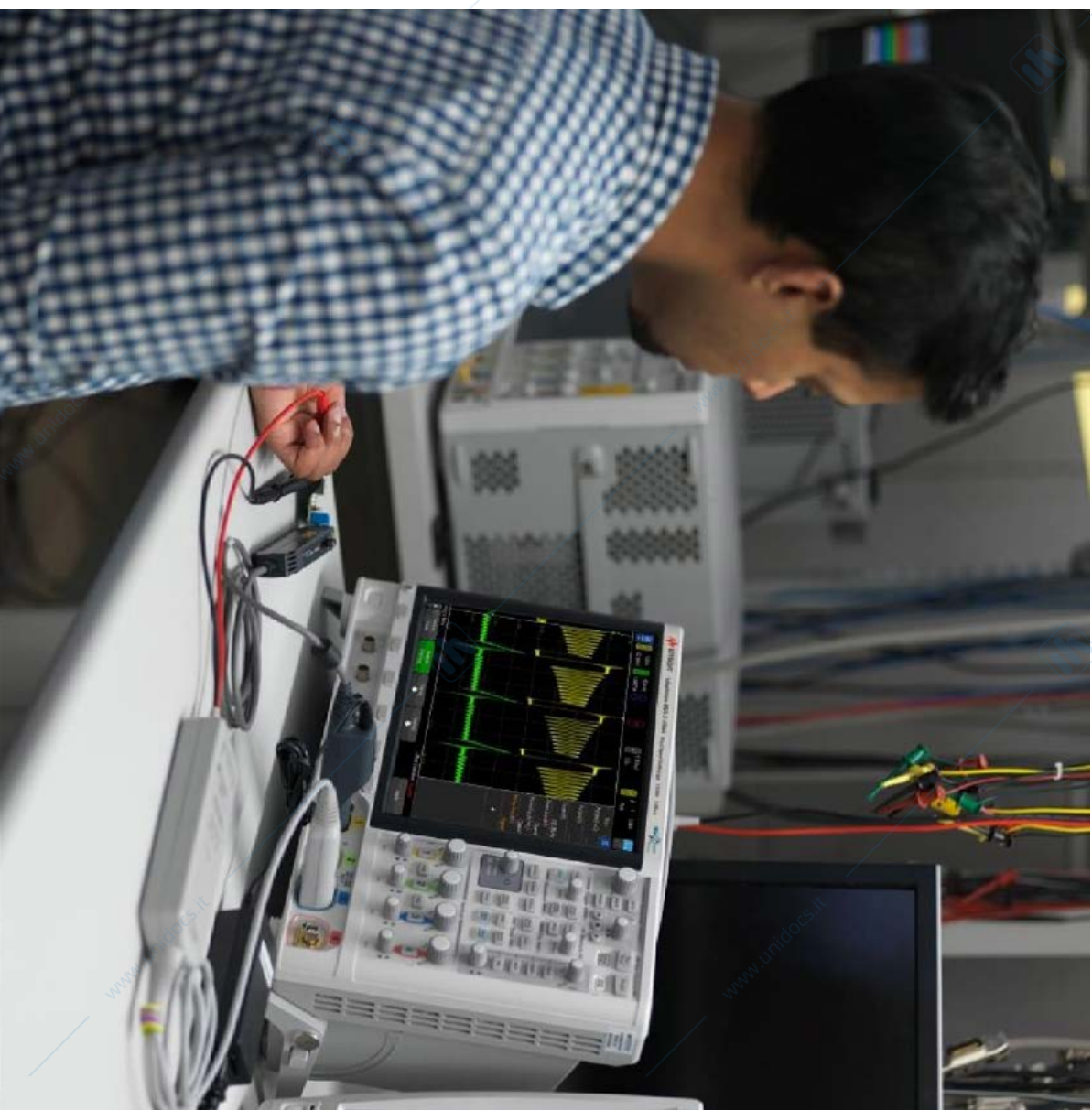

Oscilloscope Theory of Operation

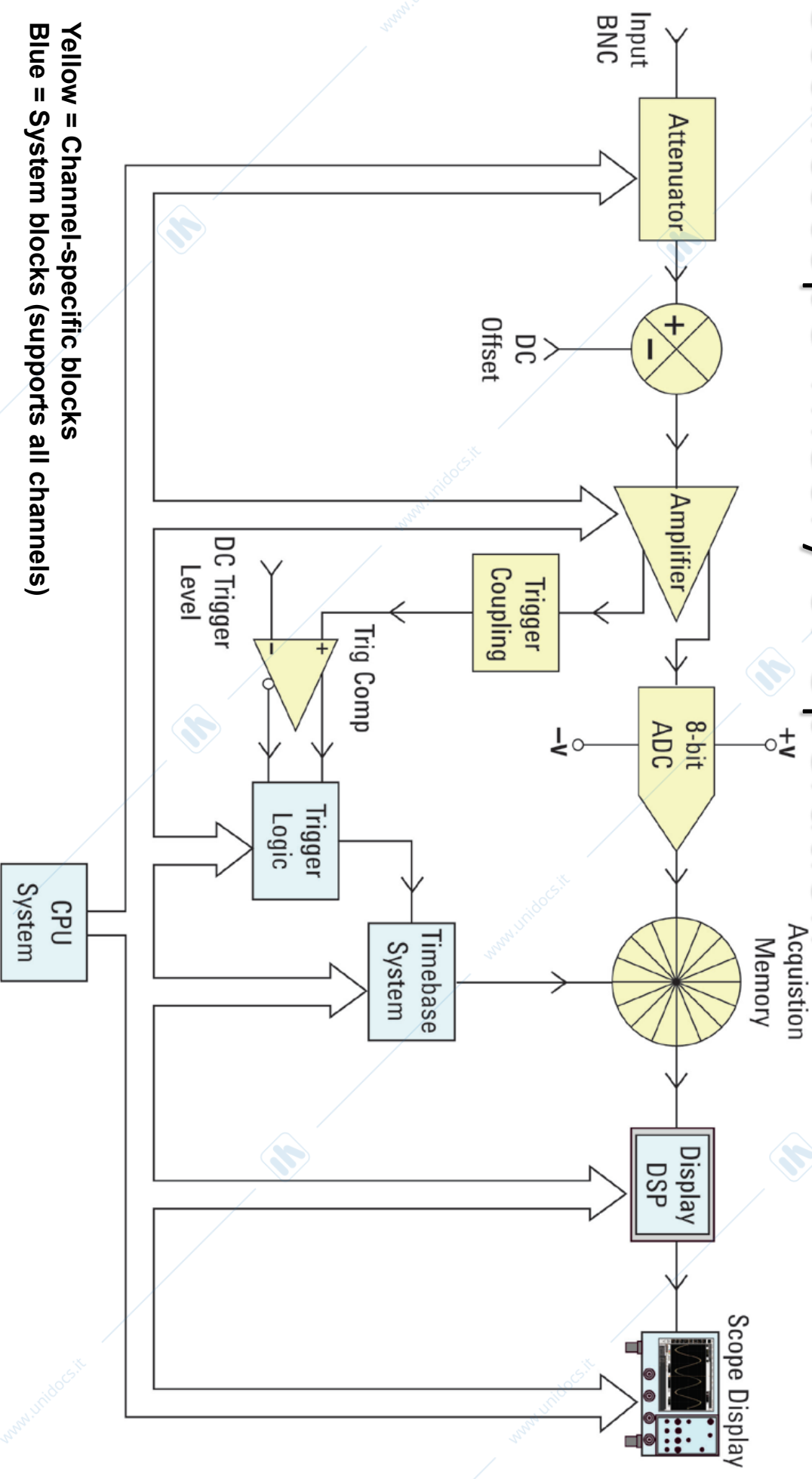

Yellow = Channel-specific blocks
 Blue = System blocks (supports all channels)

Digital Storage Oscilloscope Block Diagram

Key #1 - Bandwidth

QUICK RULE OF THUMB

“Select a scope with 5x the bandwidth of your fastest digital clock signal.”

- 100 MHz clock? Use a 500 MHz scope.
- This will capture the 5th harmonic of the square wave for better signal visualization.

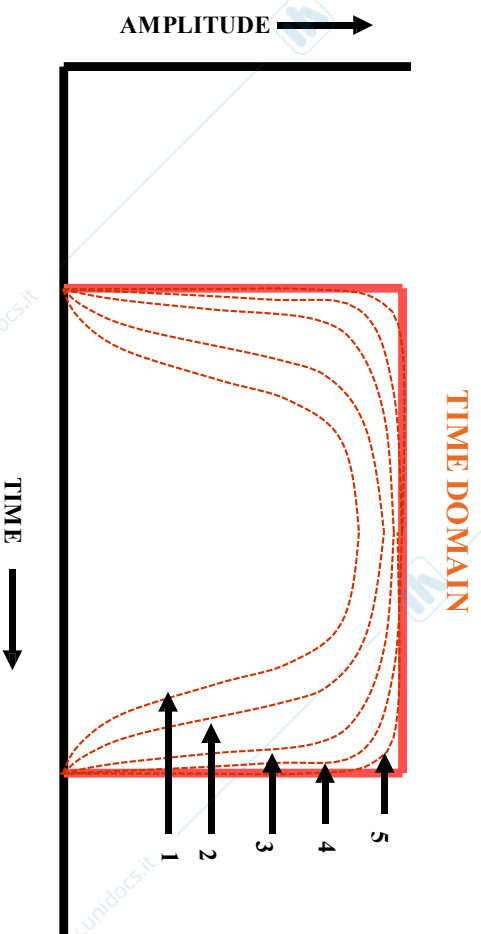
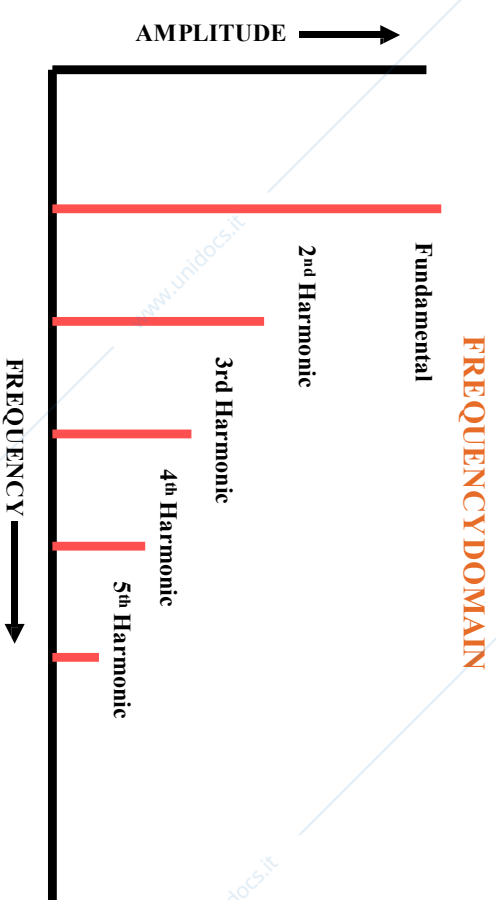

Key #1 - Bandwidth

What does a 100-MHz clock signal really look like?

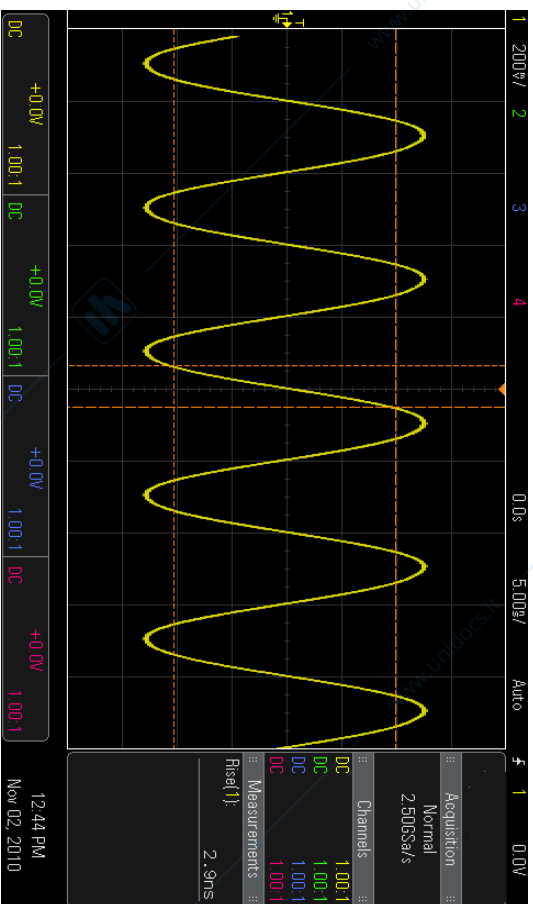

Response using a 100-MHz BW scope

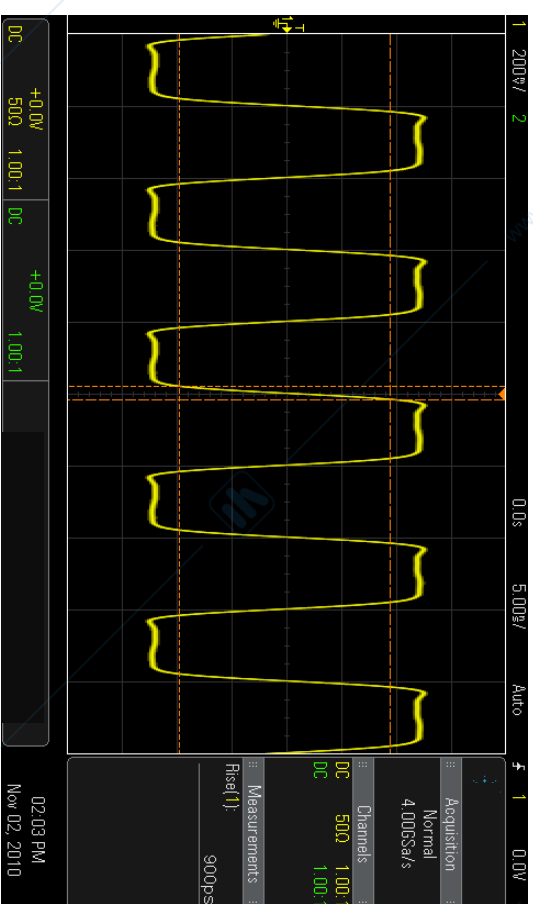

Response using a 500-MHz BW scope

Key #1 - Bandwidth

$$BW = \frac{0.35^*}{t_{ris\ e}}$$

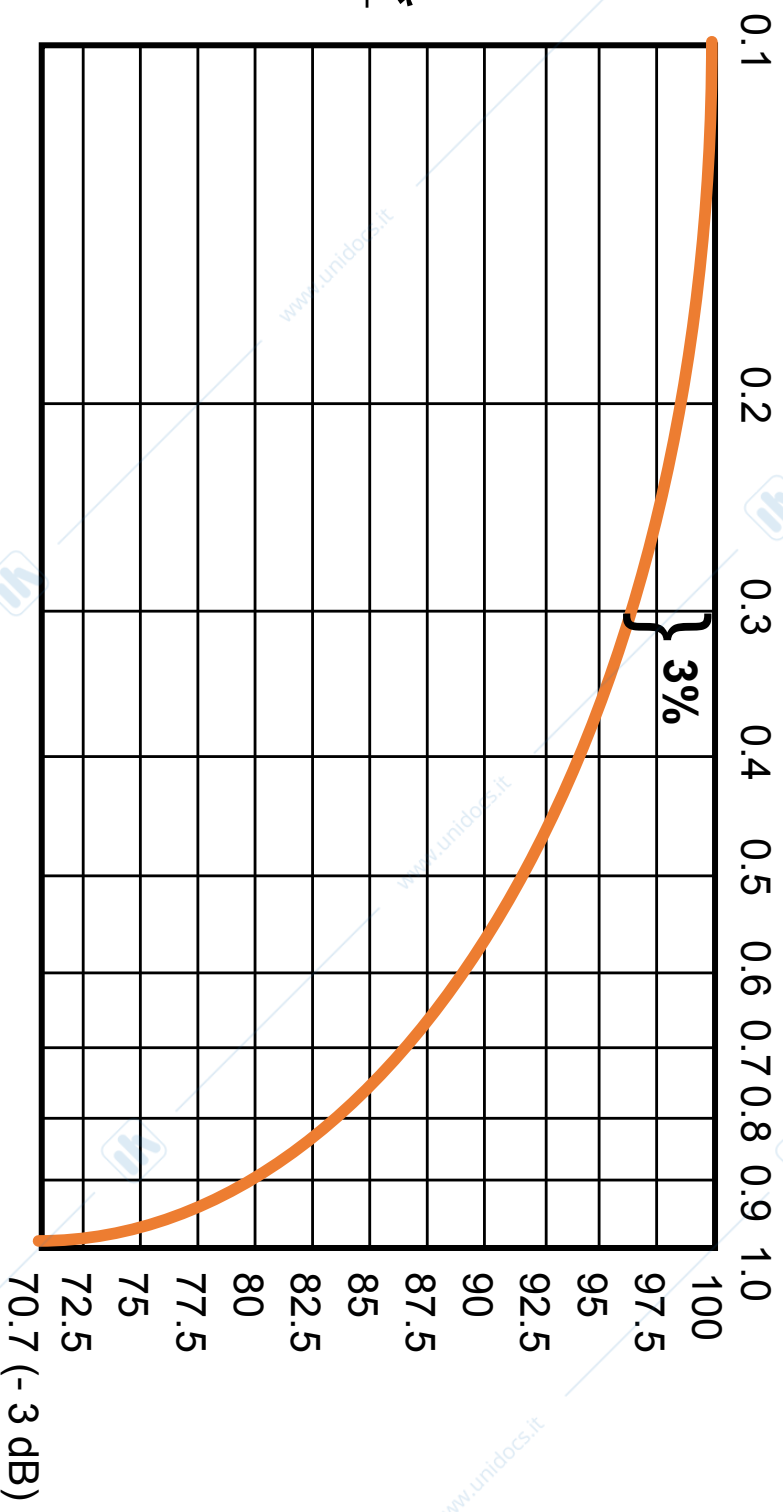

- At the 3dB bandwidth frequency, the vertical amplitude error will be approximately 30%.
- Vertical amplitude error specification is typically 3% maximum for the oscilloscope.

Key #1 - Bandwidth

CALCULATING WHAT YOU REALLY NEED

Step #1: Determine fastest rise/fall times of DUT.

Step #2: Determine highest signal frequency content

(f_{Knee})

- $f_{Knee} = 0.5/RT$ (10% - 90%)
- $f_{Knee} = 0.4/RT$ (20% - 80%)

Step #3: Determine required measurement accuracy.

Accuracy	Gaussian Response	Maximally-flat Response
20%	$BW = 1.0 \times f_{Knee}$	$BW = 1.0 \times f_{Knee}$
10%	$BW = 1.3 \times f_{Knee}$	$BW = 1.2 \times f_{Knee}$
3%	$BW = 1.9 \times f_{Knee}$	$BW = 1.4 \times f_{Knee}$

Step #4: Calculate required bandwidth.

Scope swept response measurement

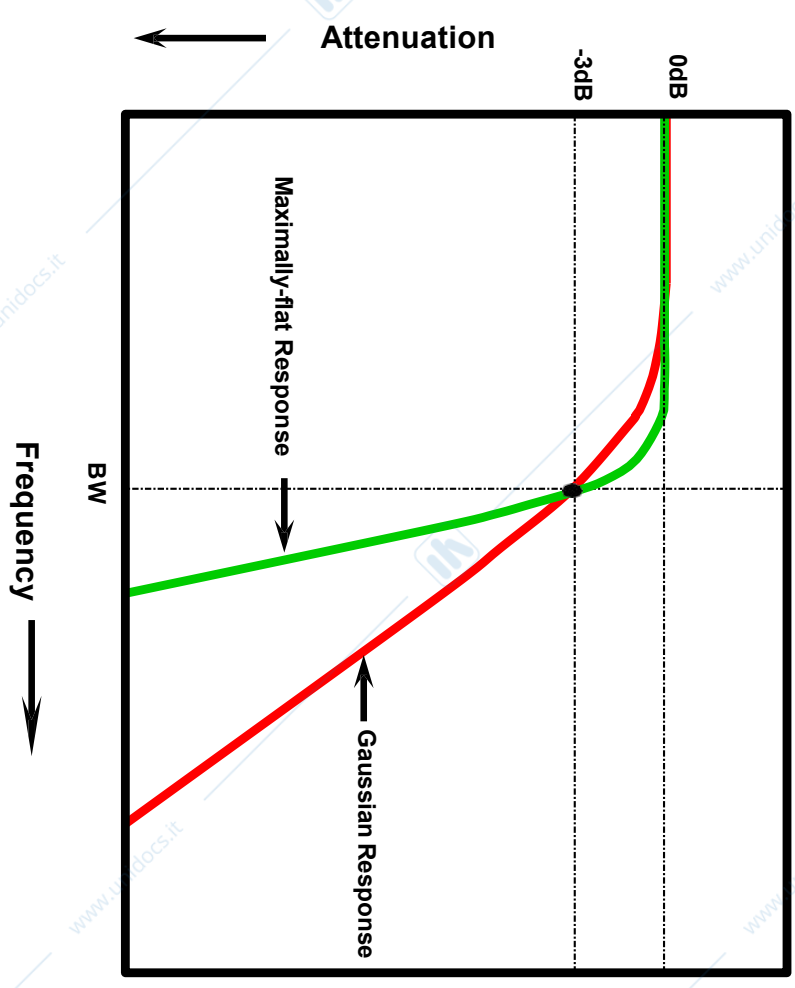
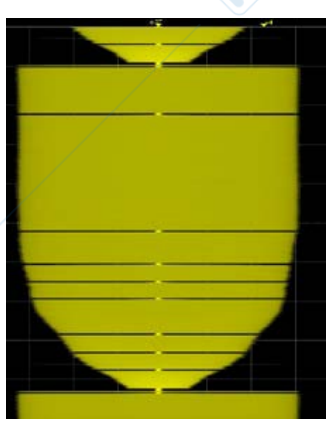

Source: Dr. Howard W. Johnson, "High-speed Digital Design - A Handbook of Black Magic."

Key #1 - Bandwidth

CALCULATING WHAT YOU REALLY NEED

Example:

We wish to measure a DUT with 1 ns 10-90% rise times.

➤ 1 ns = 1×10^{-9} s

➤ $f_{knee} = (0.5/1 \times 10^{-9} \text{ s}) = 5 \times 10^{-8} \text{ Hz} = 500 \text{ MHz}$

➤ 3% Accuracy: BW = 1.9 x 500 MHz = **950 MHz**

➤ 10% Accuracy: BW = 1.3 x 500 MHz = **650 MHz**

➤ 20% Accuracy: BW = 1.0 x 500 MHz = **500 MHz**

Key #2 – Sample Rate



Professor Smart has total trust in Dr. Nyquist and says:

“2X over the scope’s bandwidth.”



Professor Wise doesn’t trust Dr. Nyquist and says:

“10X to 20X over the scope’s bandwidth.”



The truth lies somewhere in between!

Key #2 – Sample Rate

NYQUIST'S SAMPLING THEOREM

Nyquist's sampling theorem states that for a band-limited signal with maximum frequency f_{max} , the equally spaced sampling frequency f_s must be greater than twice of the maximum frequency f_{max} in order to have the signal be uniquely reconstructed without aliasing. This is sometimes called the Nyquist frequency (F_N) or the Nyquist sampling frequency (f_s).

$$F_N = f_s = 2f_{max}$$



Key #2 – Sample Rate

100 MHZ CLOCK WITH 1 NS 10-90% EDGE SPEEDS

RECALL: 1 ns 10-90% rise times 500 MHZ

1 GSa/s

$$(f_{\text{scope}} = f_{\text{knee}} * 2 = f_N)$$

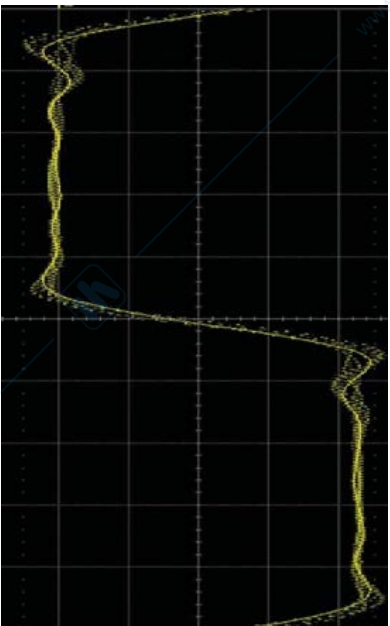

2 GSa/s

$$(f_{\text{scope}} = f_{\text{knee}} * 4 = 2f_N)$$

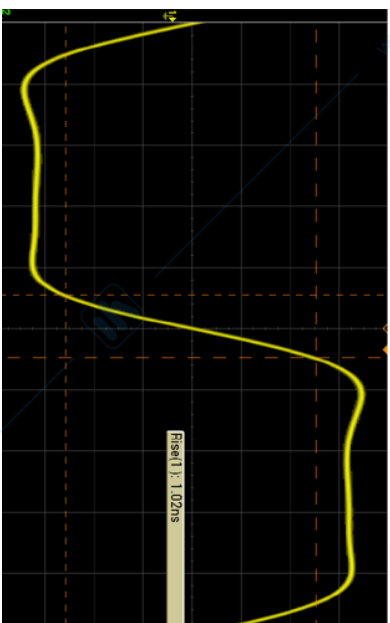

4 GSa/s

$$(f_{\text{scope}} = f_{\text{knee}} * 8 = 4f_N)$$

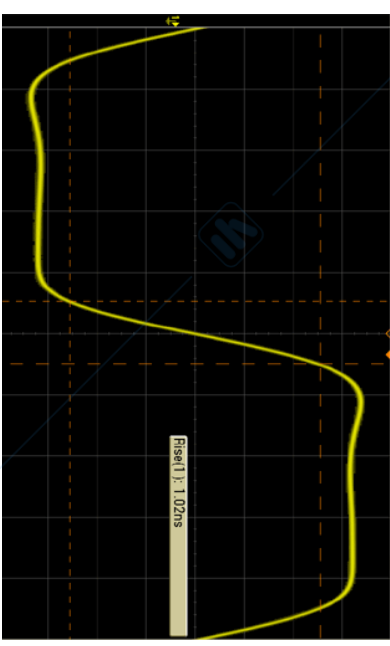

Key #3 – Memory Depth

MEMORY SIZE AND ARCHITECTURE IS IMPORTANT

More memory means more time can be shown on screen using maximum sample rate.
 But, more memory adds cost, slows down the responsiveness of the scope, and adds complexity.

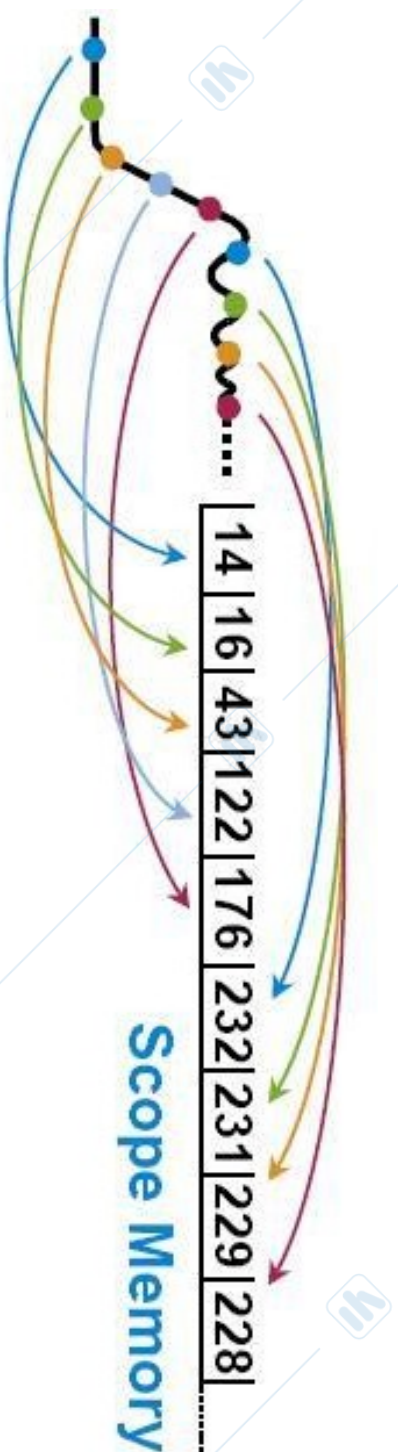

Key #3 – Memory Depth

CALCULATING WHAT YOU NEED

Step #1: Determine required maximum sample rate.

➤ Use previous Keys #1 and #2 to calculate

Step #2: Determine longest time period you need to capture

➤ Generally based on slowest signals / packets

Step #3: Determine memory needed using this equation:

$$\text{Memory Depth } (S_a) = \text{Sample Rate } \left(\frac{S_a}{s} \right) * \text{Time } (s)$$

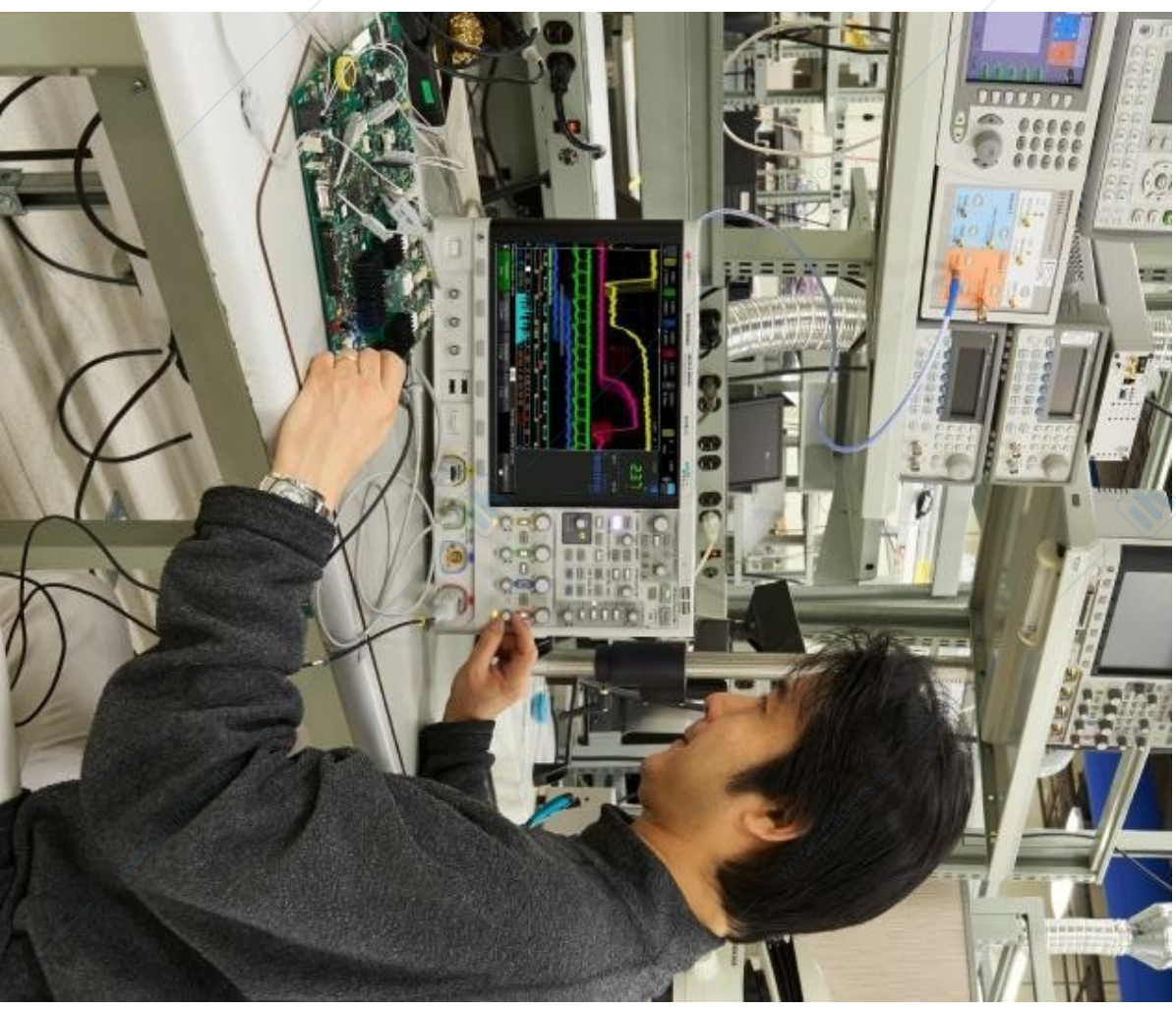

Key #3 – Memory Depth

CALCULATING WHAT YOU NEED

Example:

We wish to measure 1 ms at 2 GSa/s

- Required Sample Rate = 2 GSa/s
- Longest Time Span = 1 ms
- Required Memory Depth = $(2 \times 10^9 \text{ Sa/s}) \times (1 \times 10^{-3} \text{ s})$
= $2 \times 10^6 \text{ Sa} = 2 \text{ MSA (Mpts)}$

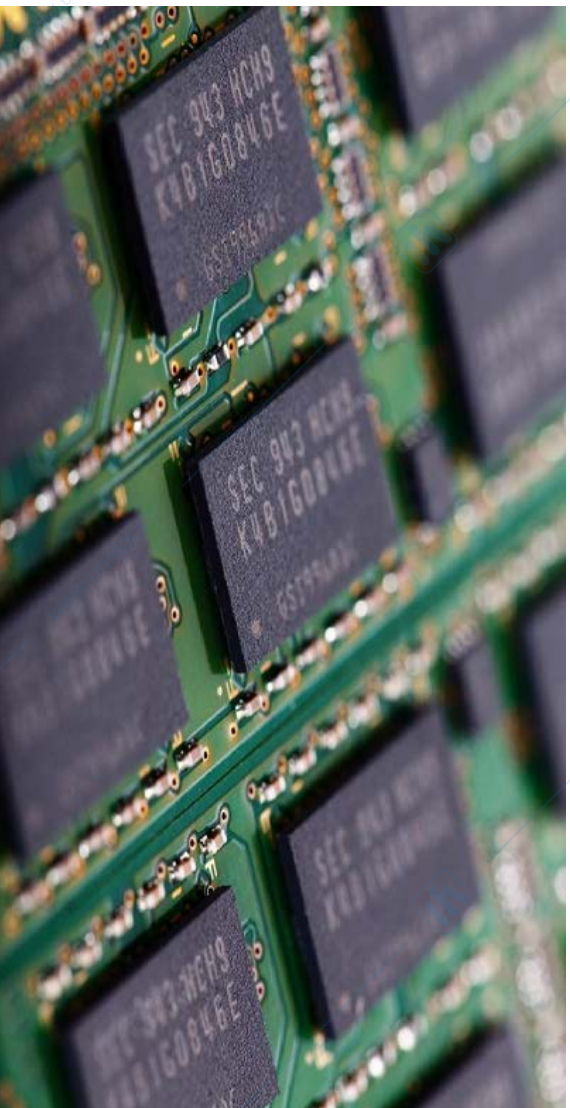

Key #3 - Memory Depth

SHORTFALL OF A TRADITIONAL DEEP MEMORY ACQUISITION

$$\text{Memory Depth (Sa)} = \text{Sample Rate} \left(\frac{\text{Sa}}{\text{s}} \right) * \text{Time (s)}$$

$$\text{Time (s)} = \text{Memory Depth (Sa)} \div \text{Sample Rate} \left(\frac{\text{Sa}}{\text{s}} \right)$$

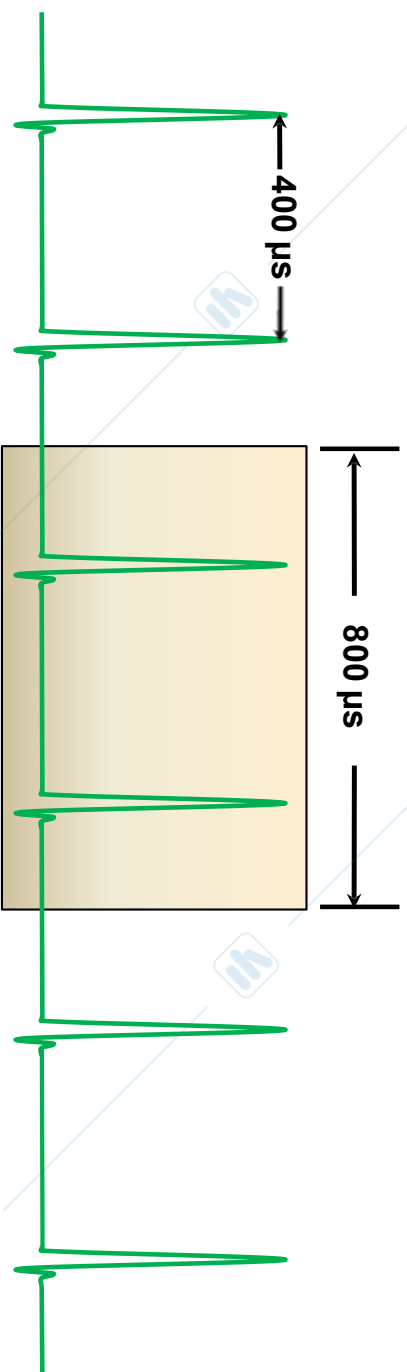

Key #3 - Memory Depth

SEGMENTED MEMORY ACQUISITION

Selectively captures more waveform data with precise time-stamps for each segment

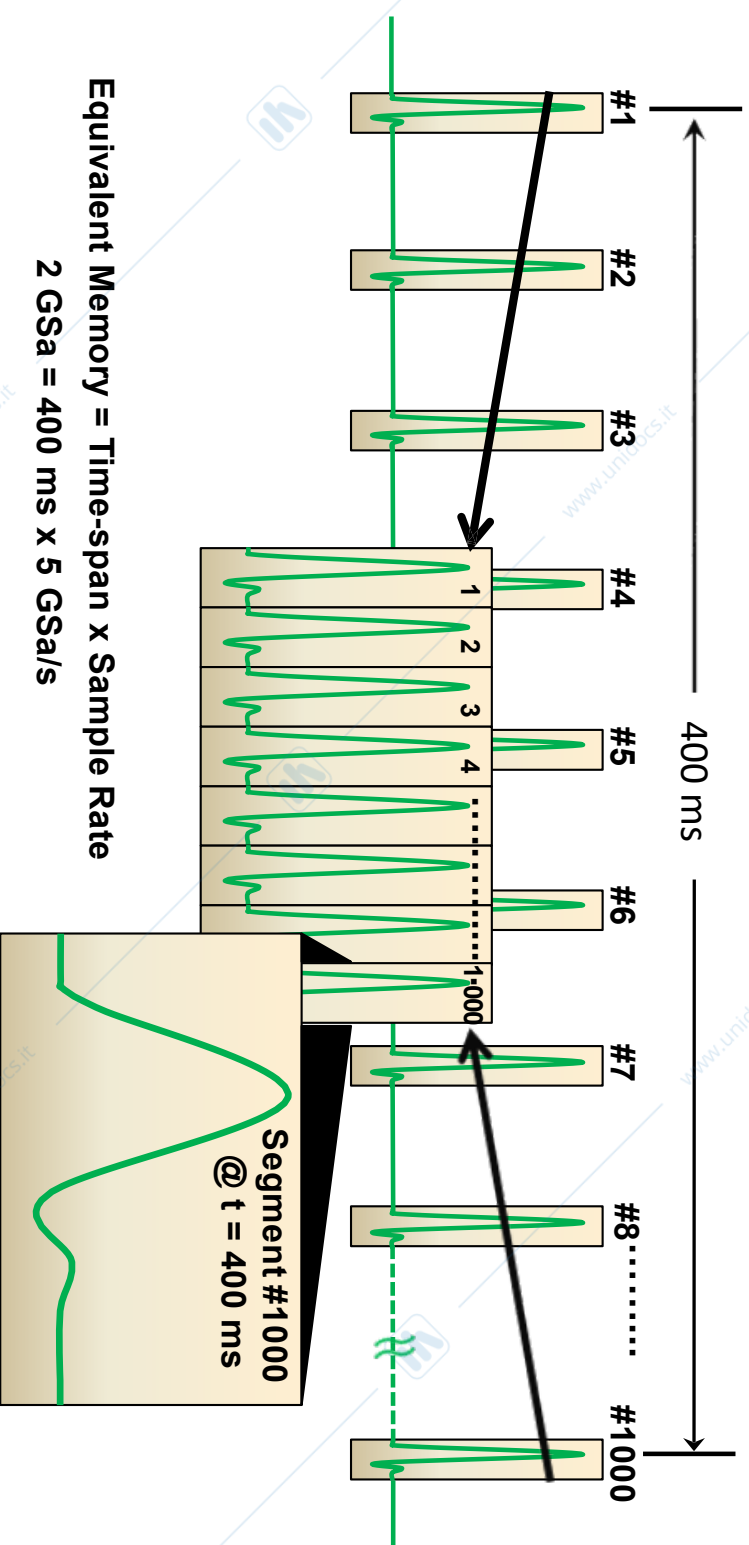

Equivalent Memory = Time-span x Sample Rate
 2 GSa = 400 ms x 5 GSa/s

Key #4 - Number of Channels

WHAT ARE THE OPTIONS?

- DSOs with 2 or 4 channels are common
- DSOs with >4 channels are less common and expensive
- Many of today's complex digital systems require measurements on more than 4 channels simultaneously.
- Solution: **Mixed Signal Oscilloscope (MSO)**



Key #4 – Number of Channels

WHAT IS AN MSO?

- Adds up to 16 extra channels that are measured with one bit of resolution (1 or 0)
- Perfect for serial or parallel logic buses, where using analog channels may be overkill
- Triggering on digital channels is a huge benefit

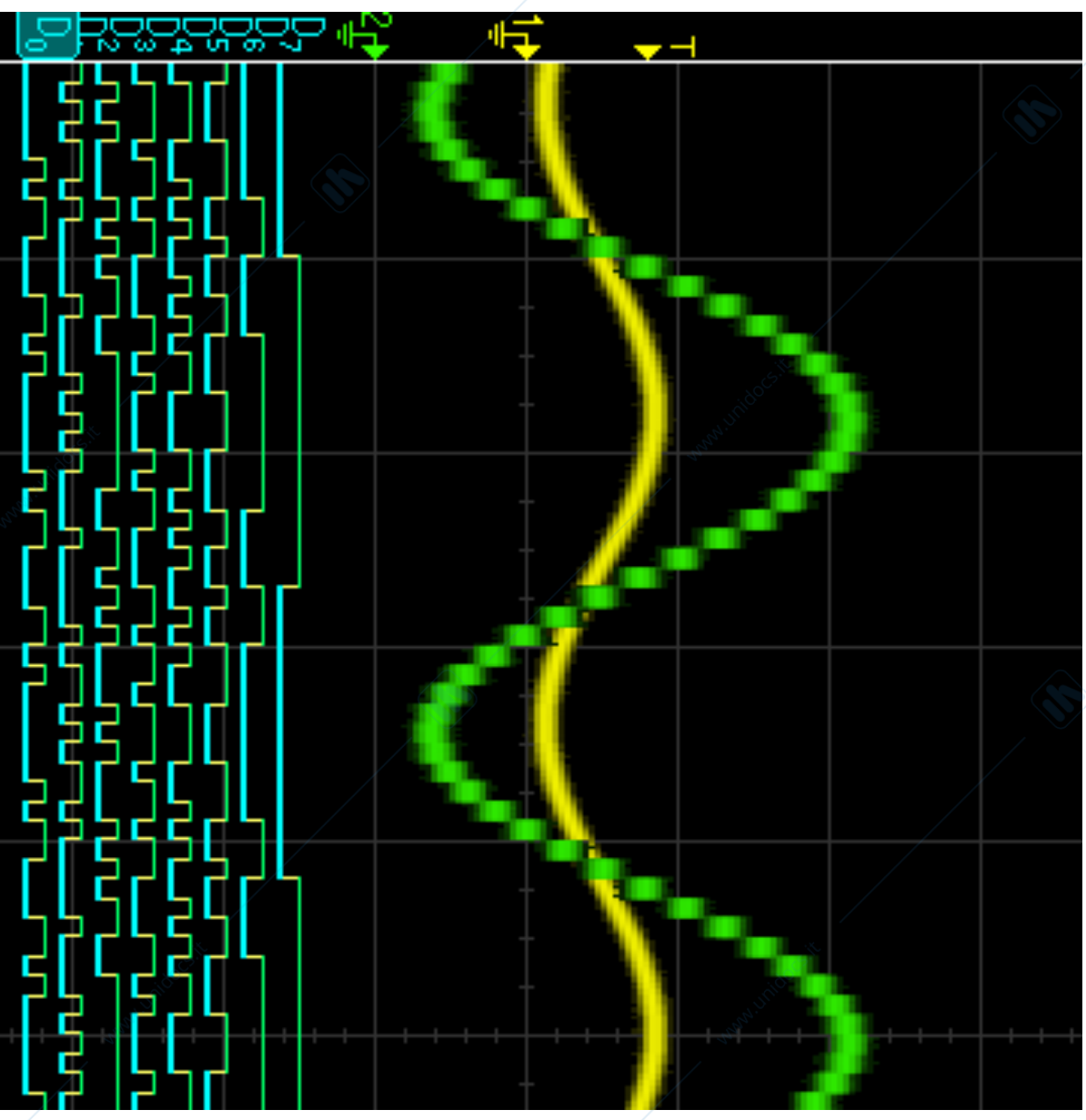

Key #5 – Waveform Update Rate

- For any scope, there is always holdoff time during a display update cycle when the signal cannot be acquired.
- The probability of seeing the low rep-rate anomaly that occurs on the measured signal decreases as this holdoff time increases.

$$\text{Probability} = \frac{\text{Acquisition (Sweep) Time}}{\text{Acquisition (Sweep) Time} + \text{System (Sweep) Holdoff Time}}$$

- You will not know this probability by simply looking at the display update.

You Cannot See What Occurs During Acquisition/Sweep Holdoff Time

Key #5 – Waveform Update Rate

HOW OFTEN CAN THE OSCILLOSCOPE SHOW ME WAVEFORMS?

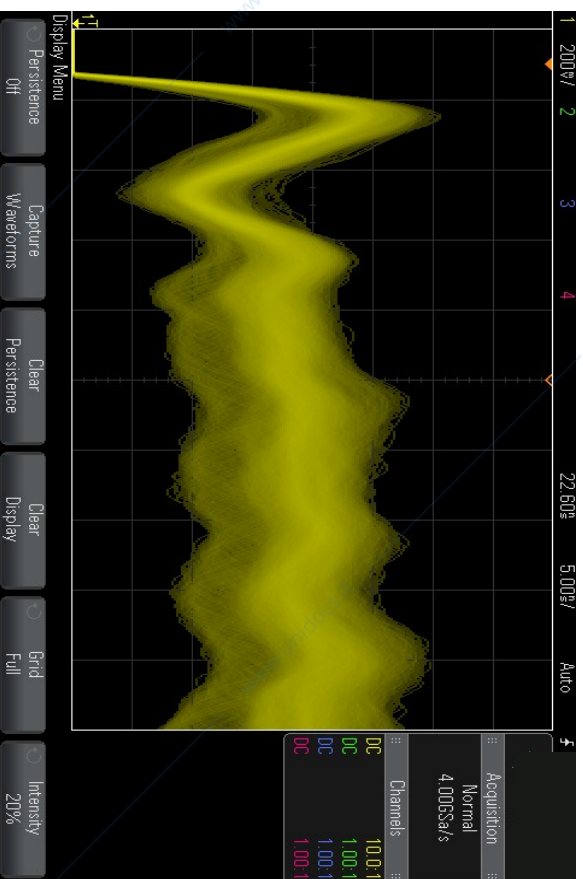

Improves scope display quality

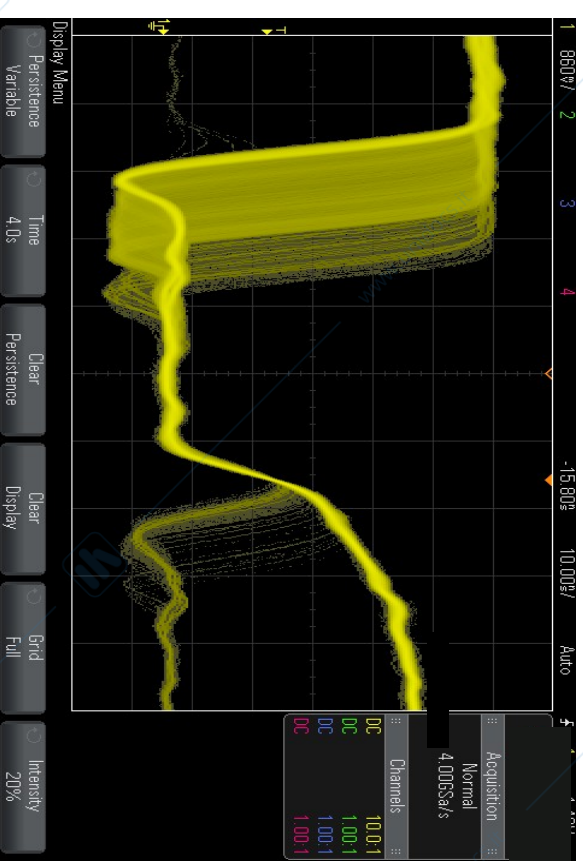

Improves scope probability of capturing infrequent events

Key #5 – Waveform Update Rate

VISUALIZING THE DIFFERENCE

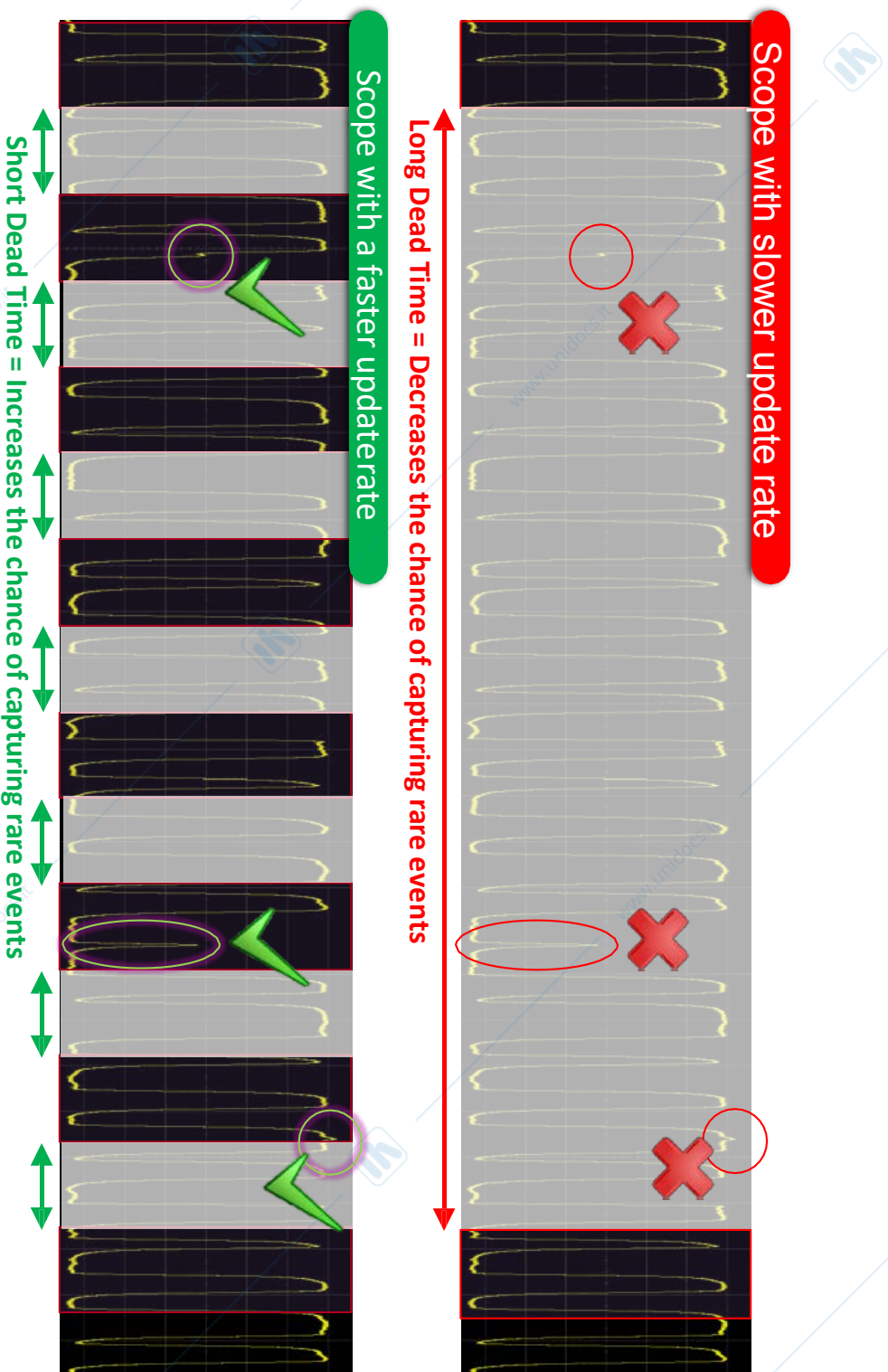

Key #5 – Waveform Update Rate

WHAT HAPPENS IF MY UPDATE RATE IS TOO SLOW?

- A slower update rate means you may miss important, fast moving, and rare events on a signal that are very important to see.
- Each acquisition is like a roll of the dice – the faster you roll the dice, the faster you can get all possible outcomes!

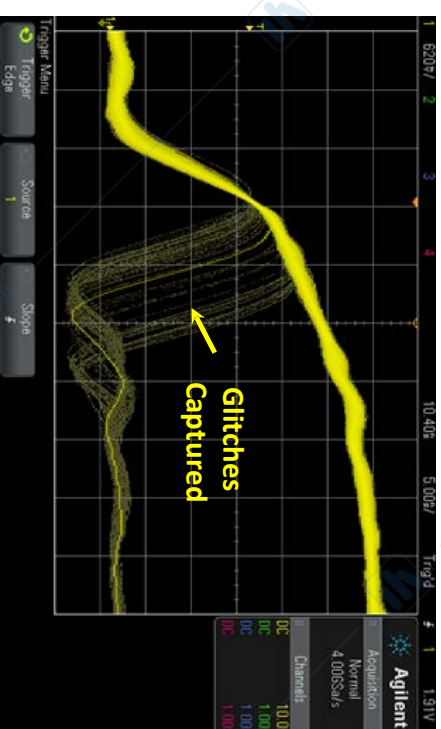

Key #5 – Waveform Update Rate

SCOPE ARCHITECTURE MATTERS

- ASIC's is the essentials of an oscilloscope multiple chips
- Memory, sample rate are automatically optimized based on timebase
- Waveform update rate maximized with 1us rearm time thanks to ASIC managing trigger, memory, and display all at once with no compromise
- CPU only used for functions that aren't speed critical (e.g. math functions)

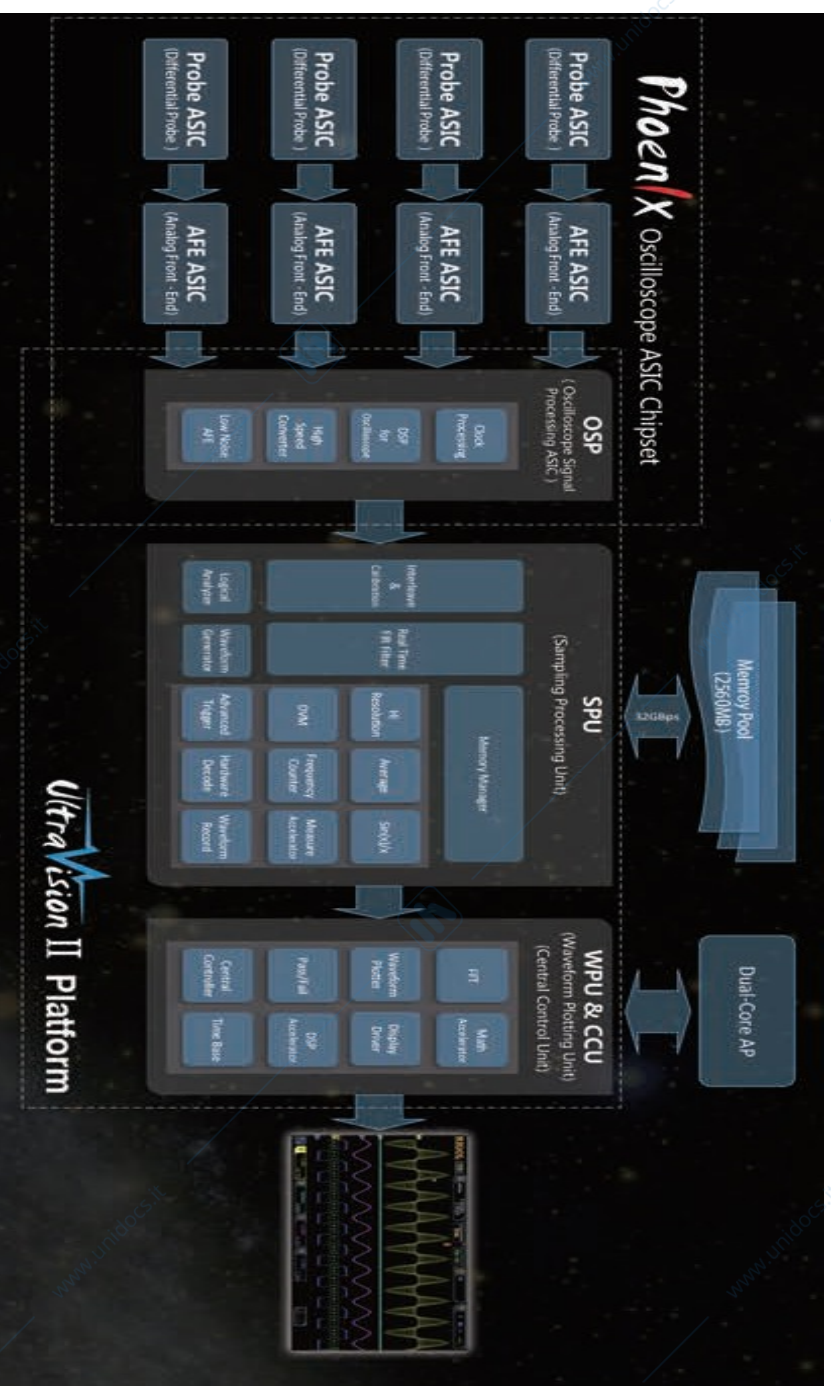

Key #6 – Advanced Triggering

HOW IMPORTANT IS TRIGGERING?

Triggering is often the least understood function of a scope, but is one of the most important capabilities that you should understand.

- Think of oscilloscope “triggering” as “synchronized picture taking”.
- One waveform “picture” consists of many consecutive digitized samples.
- “Picture Taking” must be synchronized to a unique point on the waveform that repeats.
- Most common oscilloscope triggering is based on synchronizing acquisitions (picture taking) on a rising or falling edge of a signal at a specific voltage level.



A photo finish horse race is analogous to oscilloscope triggering

Key #6 – Advanced Triggering

BASIC RISING EDGE TRIGGER (DEFAULT)



Untriggered / Auto-Trigger (unsynchronized picture taking)

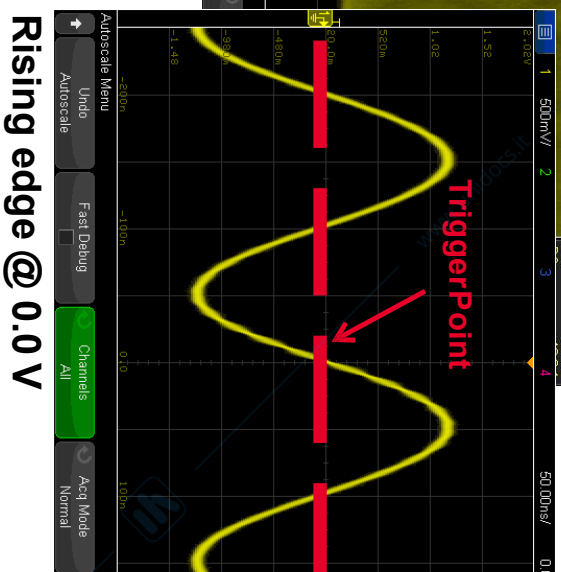

Rising edge @ 0.0V

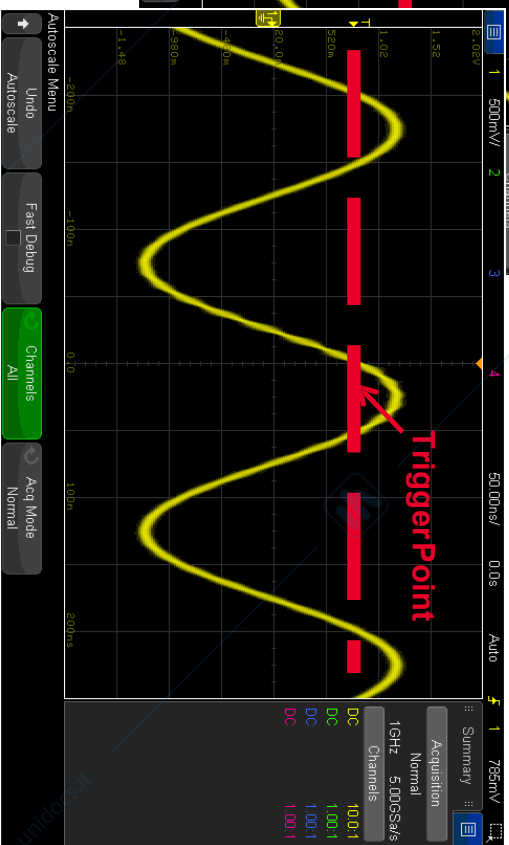

Rising edge @ +785 mV

Key #6 – Advanced Triggering

USING AN ADVANCED TRIGGER TO ISOLATE A GLITCH

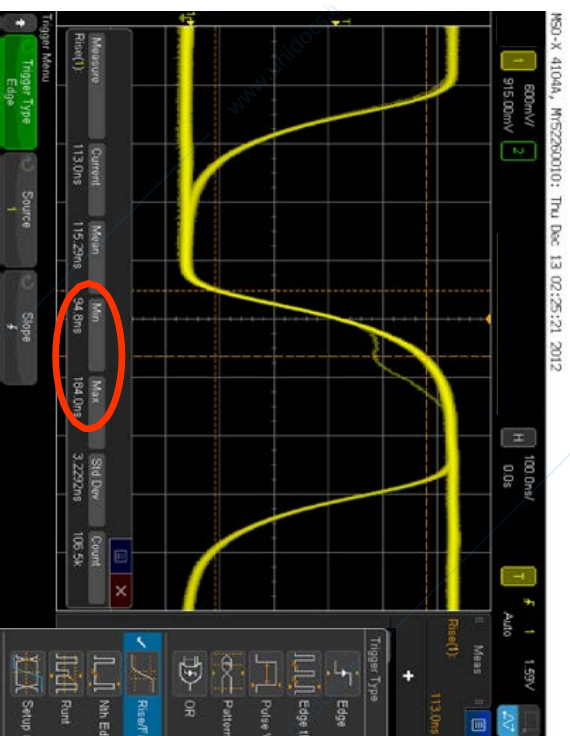

Min & Max Rise Times Measured

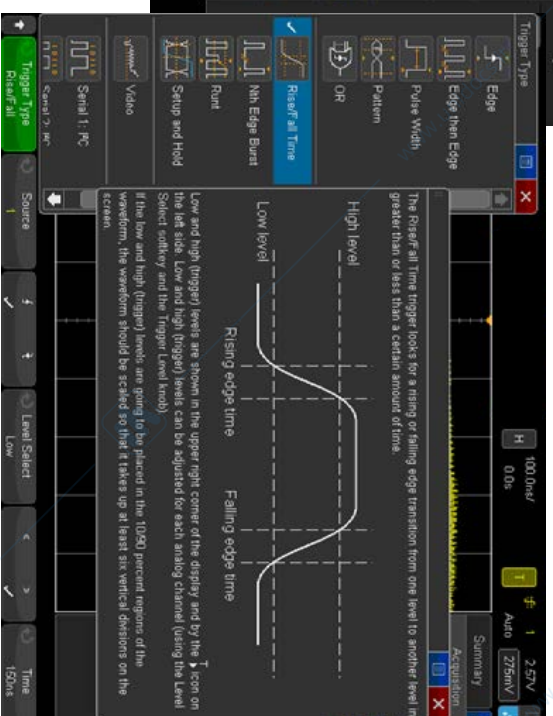

Rise/Fall Time Trigger "Help" Screen

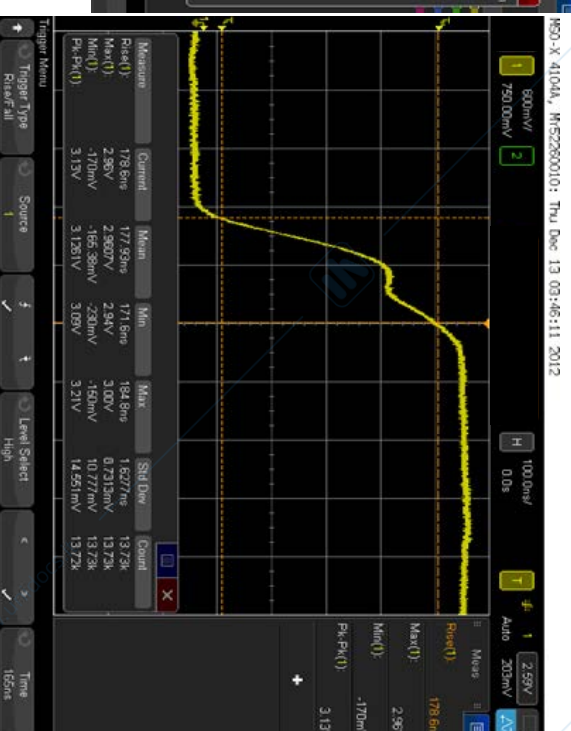

Violation Isolated (~7 steps)

Key #7 – Serial Bus Applications

WHY DO YOU NEED IT

I2C
 SPI
 RS232/UART
 CAN
 LIN
 I2S
 ... And More!



Serial buses are used pervasively in most of today's designs to communicate:

- Between functional blocks
- Chip to chip
- Board to IO
- Remote sensor to control

Key #7 – Serial Bus Applications

SYMBOLIC DECODE OF THE CAN BUS

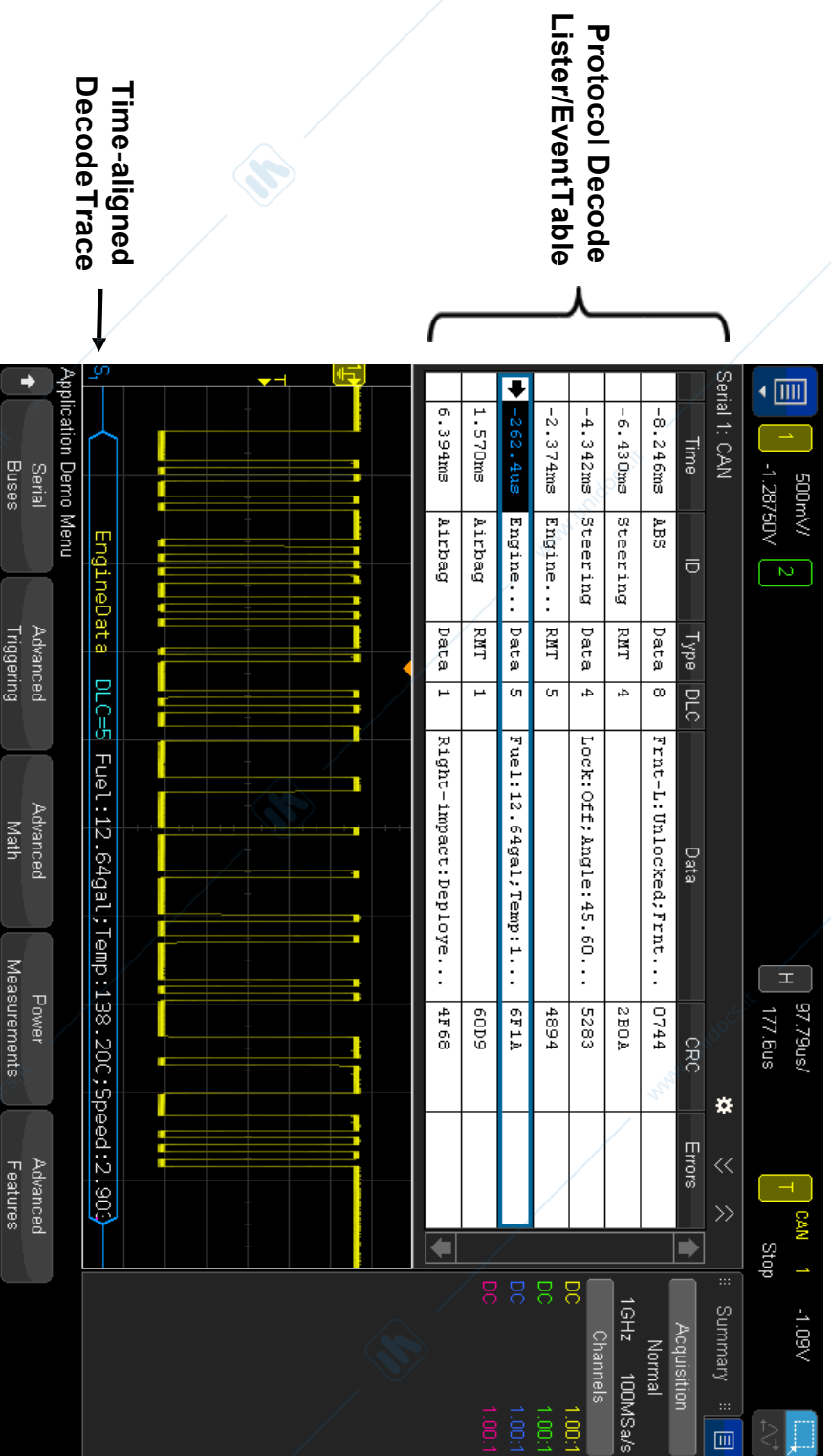

Key #8 – Measurements & Analysis

TURNING AN OSCILLOSCOPE INTO A MULTITool

Here are some functions most oscilloscopes have:

- Time & Voltage Cursors
- Parametric Measurements
- Waveform Math

Here are some that are more uncommon:

- WaveGen function generator
- Frequency Fourier trasform
- Digital voltmeter / counter
- Power supply analysis
- Pass/fail mask testing

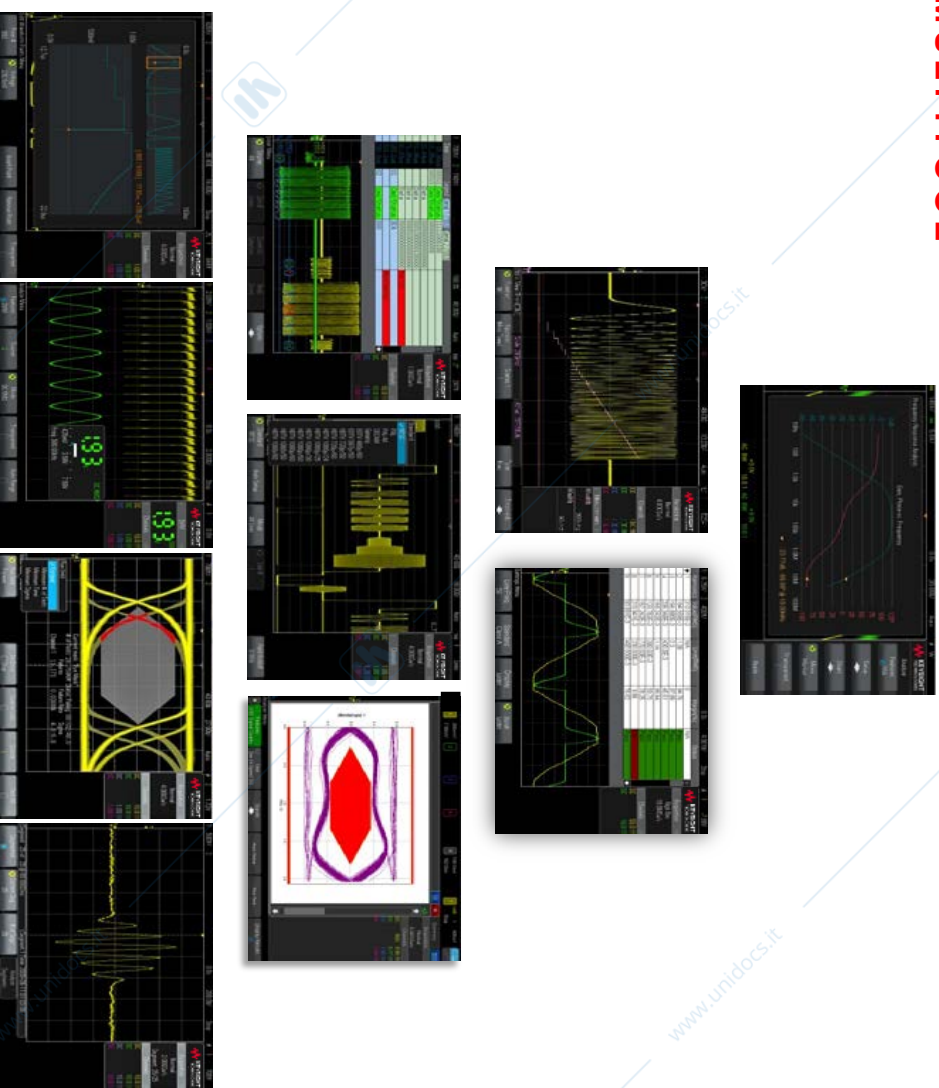

Key #9 – Connectivity and Documentation

WHAT USE IS ALL THIS DATA IF I CAN'T SHARE IT?

- USB and LAN connectivity is the industry standard for connecting instruments to PCs for extended data analysis
- LabView, Matlab or other similar software applications can coordinate an entire bench of equipment from one interface
- Controlling equipment remotely can be huge for those who work remotely, or have sites worldwide

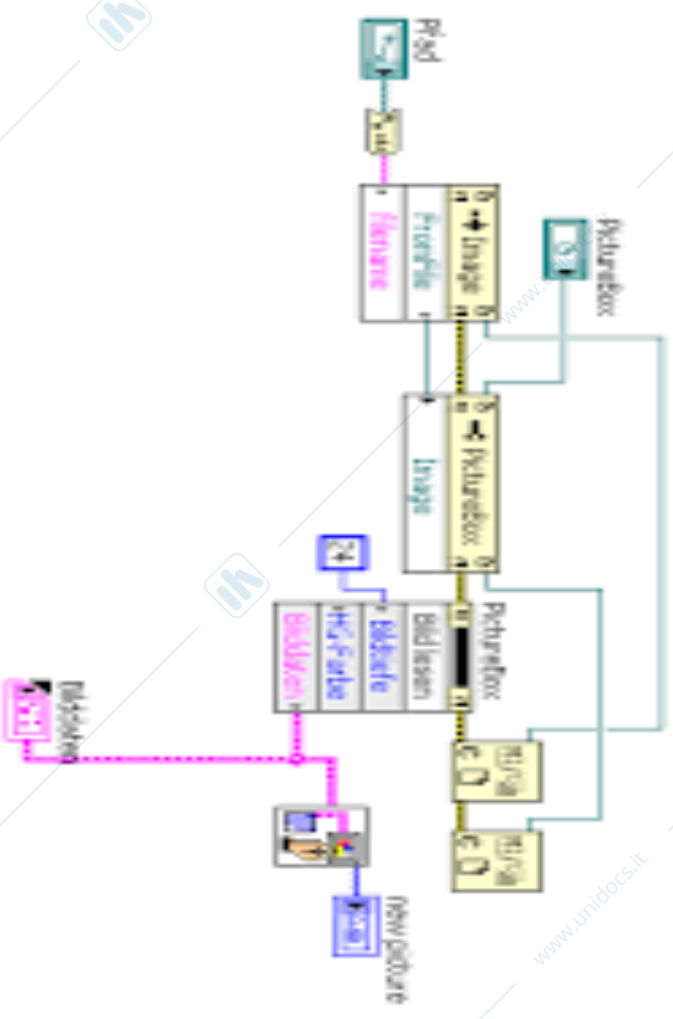
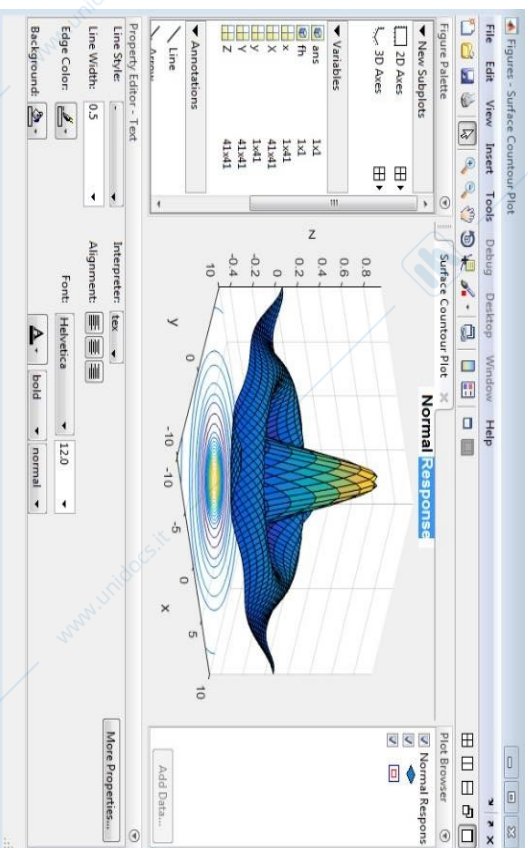







Key #10 – Probing

SELECTING THE RIGHT PROBE FOR YOUR TEST NEEDS

Scope measurements are only as good as the what the probe can deliver to the scope's inputs.

Types of Oscilloscope Probes:

- Passive probes
- High frequency active probes
- Differential active probes
- High voltage probes
- Current probes

 <p>Passive</p> <ul style="list-style-type: none">• Low cost, rugged design• Variety of accessories• Up to 1.5GHz	 <p>Single-ended Active</p> <ul style="list-style-type: none">• Up to 4 GHz• High Input R & low input C for low loading• N7020A power rail probe for PARAD measurement• For highspeed, ground referenced signal measurements	 <p>High-voltage Differential</p> <ul style="list-style-type: none">• Up to 800 MHz• Up to 7 kV• Ideal for power measurements• High common mode rejection	 <p>Active Probe</p> <ul style="list-style-type: none">• 1.5-6GHz• Making diff, SE and CM measurements with a single probe• Multi-function scope control• Includes solder-in, browser and socketed keys	 <p>Active Diff Probe</p> <ul style="list-style-type: none">• Up to 30 GHz• Probe amp/head topology• Variety of connections – browser, solder-in, socketed, SMA, ZIF Key, QuickKey	 <p>AC/DC Current Probes</p> <ul style="list-style-type: none">• New high sensitivity – 50 uA• DC to 100MHz• 50uA to 500A	 <p>Accessories</p> <ul style="list-style-type: none">• InfiniMax probe heads and accessories• Compliance test fixtures• TekProbe® adapter• BGA probe adapters• Probe positioners• Wedge adapters• etc
---	--	---	---	---	--	---

Key #10 – Probing

- System Bandwidth = Bandwidth of the Probes + Oscilloscope !

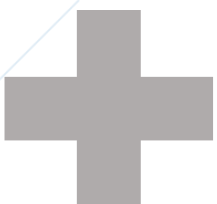

Key #10 – Probing

ACTIVE PROBE LOADING IS SUPERIOR TO PASSIVE

