

CHAPTER 16

TEMPERATURE SENSORS

From prehistoric times people were aware of heat and trying to assess its intensity by measuring temperature. Perhaps the simplest, and certainly the most widely used phenomenon for temperature sensing is thermal expansion. This forms the basis of the liquid-in-glass thermometers. For the electrical transduction, different methods of sensing are employed. Among them are: resistive, thermoelectric, semiconductive, optical, and piezoelectric detectors.

Taking a temperature essentially requires the transmission of a small portion of the object's thermal energy to the sensor, whose function is to convert that energy into an electrical signal. When a contact sensor (probe) is placed inside or on the object, heat conduction takes place through the interface between the object and the probe. The sensing element in the probe warms up or cools down, i.e., it exchanges heat with the object. The same happens when heat is transferred by means of radiation—thermal energy in a form of infrared light is either absorbed by the sensor or liberated from it depending on the object's temperature and the optical coupling. Any sensor, no matter how small, will disturb the measurement site. This applies to any method of sensing: conductive, convective, and radiative. Thus, it is an engineering task to minimize the error by an appropriate sensor design and a correct measurement technique.

There are two types of signal processing in temperature measurements: *equilibrium* and *predictive*. In the equilibrium method, a temperature measurement is complete when no thermal gradient exists between the contact surface and the sensing element inside the probe. In the predictive method, the equilibrium point is never reached: it is determined beforehand through the rate of the sensor's temperature change. After the initial probe placement, reaching thermal equilibrium between the object and the sensor may be a slow process, especially if the contact area is dry. Hence, the process of temperature equalization in the equilibrium method may take significant time. For instance, a medical electronic thermometer may take temperature from a water bath within about 10 seconds, but it will be at least 3–5 minutes when temperature is measured axillary (under the armpit).

In a contact sensing, amount of transferred heat is proportional to a temperature gradient between the thermometer's sensing element of instantaneous temperature T and that of the object T_1 :

where a is the thermal conductivity of the sensor-object interface and A is the heat transmitting surface. If the sensor has specific heat c and mass m the absorbed heat is

$$dQ = mc dT. \quad (16.2)$$

If we ignore the heat lost from the sensor to the environment through the connecting and supporting structure, Eqs. (16.1) and (16.2) yield a first order differential equation

$$aA(T_1 - T)dt = mc dT. \quad (16.3)$$

We denote thermal time constant τ_T as

$$\tau_T = \frac{mc}{aA}, \quad (16.4)$$

then differential equation takes form

$$\frac{dT}{T_1 - T} = \frac{dt}{\tau_T}. \quad (16.5)$$

This equation has a solution

$$T = T_1 - \Delta T_0 e^{-t/\tau_T}, \quad (16.6)$$

where ΔT_0 is constant equal to an initial gradient between the starting sensing element temperature T_0 and T_1 : $\Delta T_0 = T_1 - T_0$. The time transient of temperature T which corresponds to the above solution is shown in Fig. 16.1A (assuming that $T_0 = 0$). One time constant τ_T is equal to the time required for temperature T to reach

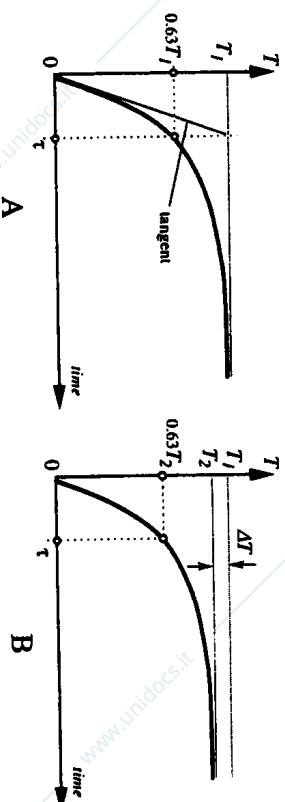

FIGURE 16.1. Temperature changes of a sensor. A: The sensor is ideally coupled with the object; B: The sensor has heat loss to its surroundings.

In this analysis we consider T_1 independent of the sensor's initial temperature. This corresponds to the case when the object has a thermal mass several orders of magnitude larger than that of the sensor and thermal conductivity of the object is high. Such an object may be called *infinite heat source* (sink).

63.2% of the initial gradient ΔT_0 . The smaller the time constant the faster the sensor responds to a change in temperature.

If in Eq. (16.6) $t \rightarrow \infty$, then temperature of the sensor becomes equal to temperature of the object: $T = T_1$. Theoretically, it takes infinite time to reach a perfect equilibrium between T_1 and T . However, since only finite accuracy is usually required, for most practical cases, a quasiequilibrium state may be considered after 5 to 10 time constants. For instance, after $t = 5\tau$ the sensor's temperature will differ from that of the object by 0.7% of the initial gradient ΔT_0 , while after 10 time constants it will be within 0.005%. If a sensor is coupled not only to the object whose temperature it detects, but to some other stray objects as well, an additional error may be introduced. An example of a stray object is a connecting cable. One end of the cable is connected to the sensor while the other part is subjected to ambient temperature which may be quite different from that of the object. The cable conducts both an electric signal and some portion of heat from or to the sensor. Figure 16.1B shows that in that case the sensor never reaches the actual temperature of the object T_1 . It settles on a lower level T_2 , which is smaller by a difference ΔT corresponding to heat loss.

A typical *contact* temperature sensor consists of the following components (Fig. 16.2A):

1. A sensing element—a material which is responsive to a change in its own temperature. A good element should have low specific heat, high thermal conductivity, strong and predictable temperature sensitivity.
2. Contacts are conductive pads or wires which interface between the sensing element and the external electronic circuit. The contacts should have the lowest possible thermal conductivity and electrical resistance. Also, they are often used to support the sensor.
3. A protective envelope is either a sheath or coating which physically separates a sensing element from the environment. A good envelope must have low thermal resistance and high electrical isolation properties. It must be impermeable to moisture and other factors which may spuriously affect the sensing element.

A noncontact temperature sensor (Fig. 16.2B) is a thermal radiation sensor whose

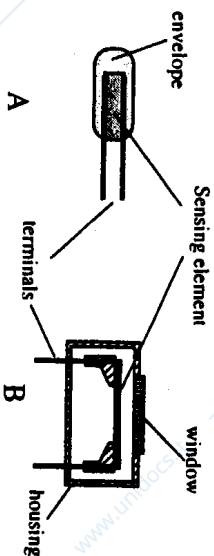

FIGURE 16.2. General structure of temperature sensors. A: A contact sensor and B: is a thermal radiation sensor.

designs are covered in detail in Chap. 13. Here, we just want to mention that like a contact sensor, it also contains a sensing element which is responsive to its own temperature. The difference is in the way of heat transfer from an object to the element: in a contact sensor it is through thermal conduction, while in a noncontact sensor it is through radiation.

To improve the time response of a thermal radiation sensor, thickness of the sensing element is minimized, while for better sensitivity its surface area is maximized. In addition to a sensing element, the noncontact thermal sensor may have an optical window and a built-in interface circuit. The interior of the sensor's housing is usually filled with dry air or nitrogen.

16.1 THERMORESISTIVE SENSORS?

Sir Humphry Davy had noted as early as 1821 that electrical resistances of various metals depend on temperature [1]. Sir William Siemens, in 1871, first outlined the use of a platinum resistance thermometer. In 1887 Hugh Callendar published a paper [2] where he described how to practically use platinum temperature sensors. The advantages of thermoresistive sensors are in the simplicity of interface circuits, sensitivity, and long-term stability. All such sensors can be divided into three groups: RTDs, *pn*-junction detectors and thermistors.

16.1.1 Resistance Temperature Detectors (RTD)

This term is usually pertinent to metal sensors, fabricated either in a form of a wire or a thin film. Temperature dependence of resistivities of all metals and most alloys gives an opportunity to use them for temperature sensing (Table A.7). While virtually all metals can be employed for sensing, platinum is used almost exclusively because of its predictable response, long-term stability, and durability. Tungsten RTDs are usually applicable for temperatures over 600 °C. All RTDs have positive temperature coefficients. Several types of them are available from various manufacturers:

1. Thin film RTDs are often fabricated of a thin platinum or its alloys and deposited on a suitable substrate, such as a micromachined silicon membrane. The RTD is often made in a serpentine shape to ensure a sufficiently large length/width ratio.
2. Wire-wound RTDs, where the platinum winding is partially supported by a high temperature glass adhesive inside a ceramic tube. This construction provides a detector with the most stability for industrial and scientific applications.

According to the International Practical Temperature Scale (IPTS-68), precision temperature instruments should be calibrated at reproducible equilibrium states of some materials. This scale designates kelvin temperatures by symbol T_{68} and the

Celsius scale by t_{68} . Eq. (3.60) gives a best fit second-order approximation for platinum. In industry, it is customary to use different approximations for the cold and hot temperatures. Callendar-van Dusen approximations represent platinum transfer function:

For the range from $-200\text{ }^{\circ}\text{C}$ to $0\text{ }^{\circ}\text{C}$

$$R_t = R_0 [1 + At + Bt^2 + Ct^3(t - 100)^3]. \quad (16.7a)$$

For the range from $0\text{ }^{\circ}\text{C}$ to $630\text{ }^{\circ}\text{C}$ is the same as Eq. (3.60)

$$R_t = R_0 [1 + At + Bt^2]. \quad (16.7b)$$

The constants A , B , and C are determined by the properties of platinum used in the construction of the sensor. Alternatively, the Callendar-van Dusen approximation can be written as

$$R_t = R_0 \left\{ 1 + \alpha \left[t - \delta \left(\frac{t}{100} \right) \left(\frac{t}{100} - 1 \right) - \beta \left(\frac{t}{100} \right)^3 \left(\frac{t}{100} - 1 \right) \right] \right\}, \quad (16.8)$$

where t is the temperature in $^{\circ}\text{C}$ and the coefficients are related to A , B , and C as

$$A = \alpha \left(1 + \frac{\delta}{100} \right), \quad B = -\alpha \cdot \delta \cdot 10^{-4}, \quad C = -\alpha \cdot \beta \cdot 10^{-8}. \quad (16.9)$$

The value of δ is obtained by the calibration at a high temperature, for example, at the freezing point of zinc ($419.58\text{ }^{\circ}\text{C}$) and β is obtained at the calibration at a negative temperature.

To conform with the IPTS-68, the Callendar-van Dusen approximation must be corrected. The correction is rather complex and the user should refer for details to the International Practical Temperature Scale of 1968. In different countries, some national specifications are applicable to RTDs. For instance, in Europe these are BS 1904: 1984, DIN 43760: 1980, IEC 751: 1983. In Japan it is JIS C1604-1981. In the U.S. different companies have developed their own standards for α -values. For example, SAMA Standard RC21-4-1966 specifies $\alpha = 0.003923\text{ }^{\circ}\text{C}^{-1}$, while in Europe DIN standard specifies $\alpha = 0.003850\text{ }^{\circ}\text{C}^{-1}$, and the British Aircraft industry standard is $\alpha = 0.003900\text{ }^{\circ}\text{C}^{-1}$.

Usually, RTDs are calibrated at standard points which can be reproduced in a laboratory with high accuracy (Table 16.1). Calibrating at these points allows for precise determination of approximation constants α and δ .

Typical tolerances for the wire-wound RTDs is $\pm 10\text{ m}\Omega$ which corresponds to about $\pm 0.025\text{ }^{\circ}\text{C}$. Giving high requirements to accuracy, packaging isolation of the device should be seriously considered. This is especially true at higher temperatures where the resistance of isolators may drop significantly. For instance, a $10\text{ M}\Omega$ shunt resistor at $550\text{ }^{\circ}\text{C}$ results in resistive error of about $3\text{ m}\Omega$ which corresponds to temperature error of $-0.0075\text{ }^{\circ}\text{C}$. www.unidocs.it - Appunti e dispense per superare i tuoi esami universitari

TABLE 16.1. Temperature reference points.

Point description	$^{\circ}\text{C}$
Triple point ^a of hydrogen	-259.34
Boiling point of normal hydrogen	-252.753
Triple point of oxygen	-218.789
Boiling point of nitrogen	-195.806
Triple point of argon	-189.352
Boiling point of oxygen	-182.962
Sublimation point of carbon dioxide	-78.476
Freezing point of mercury	-38.836
Freezing point of water	0.01
Freezing point of water (water-ice mixture)	0.00
Boiling point of water	100.00
Triple point of benzoic acid	122.37
Freezing point of indium	156.634
Freezing point of tin	231.968
Freezing point of bismuth	271.442
Freezing point of cadmium	321.108
Freezing point of lead	327.502
Freezing point of zinc	419.58
Freezing point of antimony	630.755
Freezing point of aluminum	660.46
Freezing point of silver	961.93
Freezing point of gold	1064.43
Freezing point of copper	1084.88
Freezing point of nickel	1455
Freezing point of palladium	1554
Freezing point of platinum	1769

^aTriple point is equilibrium between the solid, liquid, and vapor phases.

16.1.2 Silicon Resistive Sensors

Conductive properties of bulk silicon have been successfully implemented for the fabrication of temperature sensors with PTC characteristics. The so-called KTY temperature detectors manufactured by Philips have reasonably good linearity (which can be improved by use of simple compensating circuits), and high long-term stability (typically $\pm 0.05\text{ K}$ per year).³ The positive temperature coefficient makes them inherently safe for operation in heating systems—a moderate overheating (below $200\text{ }^{\circ}\text{C}$) results in RTD's resistance increase and a self-protection.

Pure silicon, either polysilicon or single crystal silicon, intrinsically has a negative temperature coefficient of resistance (Fig. 18.2A). However, when it is doped with an n type impurity, in a certain temperature range, its temperature coefficient becomes positive (Fig. 16.3). This is a result of the fall in the charge carrier mobility at lower temperatures. At higher temperatures, the number n of free charge carriers increases due to the number n_i of spontaneously generated charge carriers, and the

³Information on KTY sensors is courtesy of Philips Semiconductors BV, Eindhoven, The Netherlands.

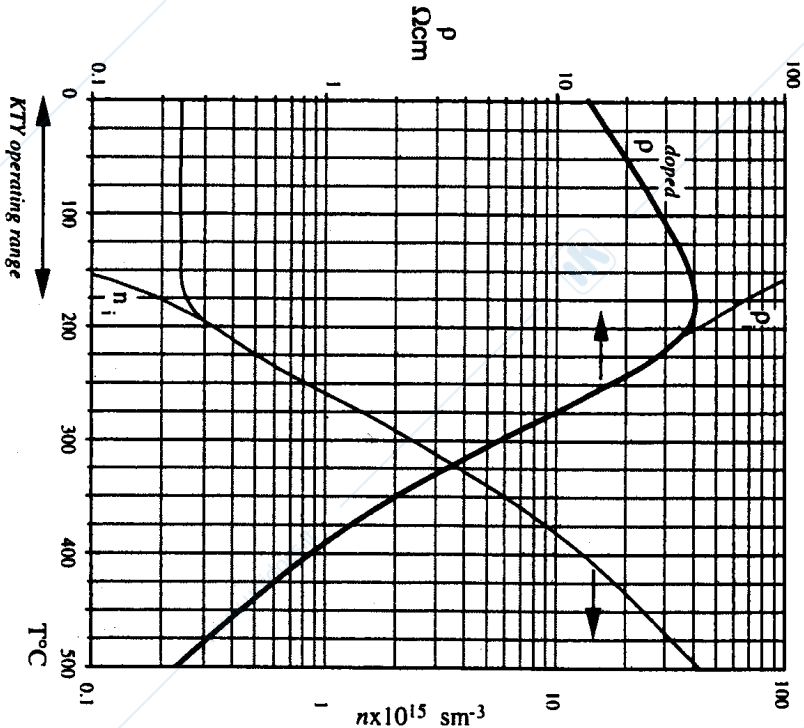

FIGURE 16.3. Resistivity and number of free charge carriers for n-doped silicon.

intrinsic semiconductor properties of silicon predominate. Thus, at temperatures below 200 °C resistivity ρ has a positive temperature coefficient while over 200 °C it becomes negative. The basic KTY sensor consists of an n type silicon cell having approximate dimensions of 500×500×240 μm , metallized on one side and having contact areas on the other side. This produces an effect of resistance "spreading" which causes a conical current distribution through the crystal, significantly reducing the sensor's dependence on manufacturing tolerances. A KTY sensor may be somewhat sensitive to a current direction, especially, at larger currents and higher temperatures. To alleviate this problem, a serially-opposite design is employed where two of the sensors are connected with opposite polarities to form a dual sensor.

A typical sensitivity of a PTC silicon sensor is on the order of 0.7%/°C, that is its resistance changes by 0.7% per every degree C. As for any other sensor with a mild nonlinearity, the KTY sensor transfer function may be approximated by a second-order polynomial

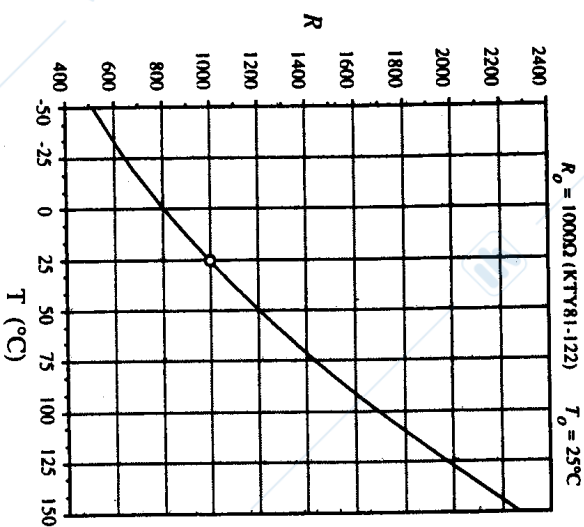

FIGURE 16.4. Transfer function of a KTY silicon temperature sensor.

$$R_T = R_0 [1 + A(T - T_0) + B(T - T_0)^2], \quad (16.10)$$

where R_0 and T_0 are the resistance (Ω) and temperature (K) at a reference point. For instance, for the KTY-81 sensors operating in the range from -55 to +150 °C, the coefficients are: $A=0.007874 \text{ K}^{-1}$ and $B=1.874 \cdot 10^{-5} \text{ K}^{-2}$. A typical transfer function of the sensor is shown in Fig. 16.4.

16.1.3 Thermistors

The term thermistor is a contraction of words *thermal* and *resistor*. The name is usually applied to metal-oxide sensors fabricated in a form of droplets, bars, cylinders, rectangular flakes, and thick films. The thermistors are divided into two groups: NTC (negative temperature coefficient) and PTC (positive temperature coefficient).

NTC Thermistors

A conventional metal-oxide thermistor has a *negative temperature coefficient* (NTC), that is, its resistance decreases with the increase in temperature. The NTC thermistor element resistance, as of any resistor, is determined by its physical dimensions and material resistivity. The relationship between the resistance and temperature is highly nonlinear (Fig. 3.19).

The equivalent circuit of a thermistor is depicted in Fig. 16.5A. It consists of a temperature dependent resistive element R_T , and constant resistors r_s and $1/g_p$, where g_p is small conductance. For the practical purposes, the thermistor's transfer function can be approximated either by a polynomial or, what is most popular for the moderate accuracy applications, by an exponential function:

$$\frac{1}{R - r_s} = g_p + \frac{1}{R_o} e^{-\beta/(T - T_o)} \quad (16.11)$$

The resistance r_s is called a series resistance (its value is small and negative), R_o and T_o are called the reference resistance and temperature respectively, and β (beta) is a number representative of the temperature sensitivity and is called a *characteristic temperature* of a thermistor.

To evaluate values of R_T , r_s , g_p , and β , four calibrating temperatures T_1 , T_2 , T_3 , and T_4 must be selected (all temperatures and β are in kelvin). One of these temperatures may be equal to T_o . Preferably the temperatures shall be equally spaced within the operating range. After measuring resistances R_i at these four temperatures, four nonlinear equations can be written:

$$\frac{1}{R_i - r_s} = g_p + \frac{1}{R_o} e^{-\beta/(T_i - T_o)} \quad (16.12)$$

where $i = 1, 2, 3$, and 4 and solving these four equations yields the real values of the four thermistor parameters. Usually, the values of r_s and g_p are quite small and if considered equal to zero, Eq. (16.12) can be simplified as

$$R = R_o e^{-\beta/(T - T_o)} \quad (16.13)$$

To evaluate parameters R_o and β of Eq. (16.13) only two test temperatures T_1 and T_2 are required and value of β (in degrees kelvin) is determined by measuring

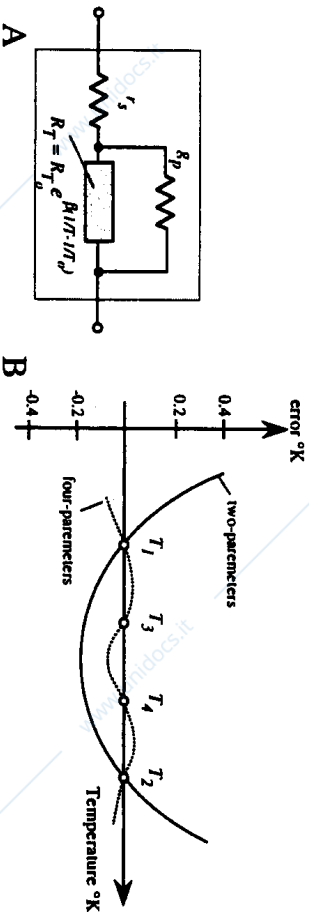

FIGURE 16.5. An equivalent circuit diagram of NTC thermistor (A) and error of a thermistor sensor resulted from use of four- and two-parameter approximations (B).

resistances R_1 and R_2 at these temperatures (one of the temperatures may be equal to T_o)

$$\beta = \frac{1}{\frac{1}{T_1} - \frac{1}{T_2}} \ln \frac{R_1}{R_2} \quad (16.14)$$

This formula may be sufficiently accurate for a narrow temperature range application.

Figure 16.5 shows accuracy of thermistor approximations by using four parameters (R_T , r_s , g_p , and β) and two parameters (R_T and β), and respectively two and four calibrating points. It is seen that use of all four parameters yields a much smaller error.

Beta specifies a thermistor curve, but it does not directly describe its sensitivity, which is a negative temperature coefficient, α (NTC). It can be found by differentiating Eq. (16.13)

$$\alpha = \frac{1}{R} \frac{dR}{dT} = -\frac{\beta}{T^2} \quad (16.15)$$

It is seen that NTC depends on both: beta and a temperature. A thermistor is much more sensitive at lower temperatures and its sensitivity (NTC) drops fast with a temperature increase. In the reality, β is not constant, and depends on temperature quite noticeably. It is not unusual to select to different pairs of T_1 and T_2 for Eq. (16.12) and calculate two different values of β for the same thermistor. Therefore, the exponential expressions Eqs. (16.11) and (16.13) are good enough only for the nondemanding applications.

For precision measurements, the so-called Steinhart-Hart relationship has a wide industry acceptance for computation of temperature in kelvin T through the thermistor's resistance. The equation is an empirical third order polynomial

$$\frac{1}{T} = A + B \ln R_T + C \ln^3 R_T \quad (16.16)$$

where A , B , and C are coefficients derived experimentally. To find these coefficients, a system of three equations should be solved for three different temperatures. The Steinhart-Hart equation explicit in resistance takes the form

$$R_T = \exp \left\{ \left[-\frac{\alpha}{2} + \sqrt{\frac{\alpha^2}{4} + \frac{\beta^3}{27}} \right]^{1/3} + \left[-\frac{\alpha}{2} - \sqrt{\frac{\alpha^2}{4} + \frac{\beta^3}{27}} \right]^{1/3} \right\} \quad (16.17)$$

where

$$\alpha = \frac{1}{A - \frac{1}{T}}, \quad \beta = \frac{B}{C} \quad (16.18)$$

Equation (16.17) yields an accuracy of about ± 0.02 °C. For more precision measurements, higher order polynomials may be employed.

In the NTC thermistors, the sensitivity α varies over the temperature range from -2 (at the warmer side of the scale) to $-8\%/^{\circ}\text{C}$ (at the cooler side of the scale), which implies that this is a very sensitive device, roughly an order of magnitude more temperature sensitive than RTD. This is especially important in applications where a high output signal over a relatively narrow temperature range is desirable.

Generally, thermistors can be classified into three major groups depending upon the method by which they are fabricated. The first group consists of bead type thermistors. The beads may be bare, or coated with glass (Fig. 16.6), epoxy, or encapsulated into a metal jacket. All these beads have platinum alloy leadwires which are sintered into the ceramic body. When fabricated, a small portion of mixed metal oxide with a suitable binder is placed onto a parallel leadwires, which are under slight tension. After the mixture has been allowed to dry, or has been partly sintered, the strand of beads is removed from the supporting fixture and placed for the final sintering into a tubular furnace. The metal oxide shrinks onto the leadwires during this firing process and forms an intimate electrical bond. Then, the beads are individually cut from the strand, and are given an appropriate coating.

Another type of thermistor is a chip thermistor with surface contacts for the leadwires. Usually, the chips are fabricated by a tape casting process, with subsequent screen printing, spraying, painting, or vacuum metallization of the surface



FIGURE 16.6. Glass coated bead thermistors. (Courtesy of Keystone-Thermometrics, Inc.)

electrodes. The chips are either bladed or cut into desired geometry. If desirable, the chips can be ground to meet the required tolerances.

The third type of thermistors are fabricated by the depositing of semiconductive materials on a suitable substrate, such as glass, alumina, silicon, etc. These thermistors are preferable for integrated sensors and for a special class of thermal infrared detectors.

Among the metallized surface contact thermistors, flakes, and uncoated chips are the least stable. A moderate stability may be obtained by epoxy coating. The bead type with leadwires sintered into the ceramic body permit operation at higher temperatures—up to 550 °C. The metallized surface contact thermistors usually are rated up to 150 °C.

Whenever a fast response time is required, bead thermistors are preferable, however, they are more expensive than the chip type. Besides, the bead thermistors are more difficult to trim to a desired nominal value.

While using the NTC thermistors, one must not overlook possible sources of error. One of them is aging, which for the low quality sensors may be as large as $+1\%/year$. Figure 16.7 shows typical percentage changes in resistance values for the epoxy encapsulated chip thermistors as compared with the sintered glass encapsulated thermistors. A good environmental protection and pre-aging is a powerful method of sensor characteristic stabilizing. During pre-aging, the thermistor is maintained at $+300$ °C for at least 700 hours. For the better protection, it may be further encapsulated into a stainless steel jacket and potted with epoxy.

Another issue which is important for the thermistor performance is a self-heating effect. A thermistor is an active type of a sensor, that is, it does require an excitation signal for its operation. The signal is usually either a dc or ac current passing through the thermistor. The current causes a Joule heating and a subsequent increase in temperature. In many applications, this is a source of error which may result in the wrong determination of the temperature of a measured object. In many other

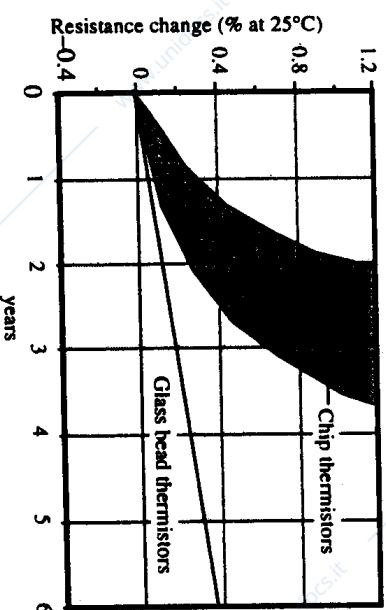

FIGURE 16.7. Long-term stability of thermistors.

applications, the self-heating is successfully employed for sensing fluid flow, thermal radiation and other stimuli.

Let us analyze the thermal events in a thermistor, when electric power is applied. Figure 16.8A shows a voltage source E connected to a thermistor R_T through a current limiting resistor R .

When electric power P is applied to the network (moment on in Fig. 16.7B), the rate at which energy is supplied to the thermistor must be equal the rate at which energy H_L is lost plus the rate at which energy H_s is absorbed by the thermistor body. The absorbed energy is stored in the thermistor's thermal capacity C . The power balance equation is

$$\frac{dH}{dt} = \frac{dH_L}{dt} + \frac{dH_s}{dt} \quad (16.19)$$

According to the law of conservation of energy, the rate at which thermal energy is supplied to the thermistor is equal to electric power delivered by voltage source E

$$\frac{dH}{dt} = P = \frac{V_T^2}{R} = V_T^2 i, \quad (16.20)$$

where V_T is the voltage drop across the thermistor.

The rate at which thermal energy is lost from the thermistor to its surroundings is proportional to temperature gradient ΔT between the thermistor and surrounding temperature T_a

$$P_L = -\frac{dH_L}{dt} = \delta \Delta T = \delta(T_s - T_a), \quad (16.21)$$

where δ is the so-called *dissipation factor* which is equivalent to thermal conductivity from the thermistor to its surroundings. It is defined as a ratio of dissipated power and temperature gradient (at a given surrounding temperature). The factor

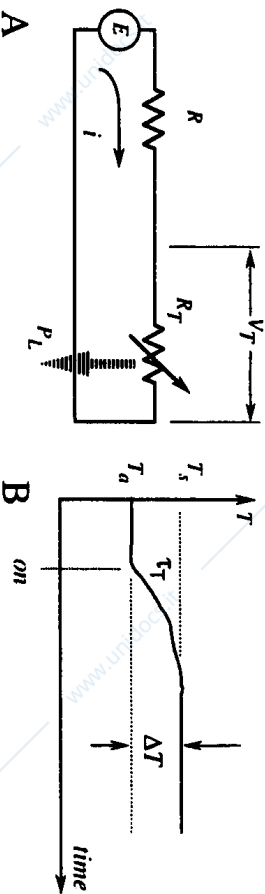

FIGURE 16.8. A: Current through thermistor causes self-heating. B: temperature of thermistor rises with thermal time constant τ_T . P_L is thermal power lost to surroundings.

depends upon the sensor design, length and thickness of leadwires, thermistor material, supporting components, thermal radiation from the thermistor surface, and relative motion of medium in which the thermistor is located.

The rate of heat absorption is proportional to thermal capacity of the sensor assembly

$$\frac{dH_s}{dt} = C \frac{dT_s}{dt} \quad (16.22)$$

This rate produces the thermistor's temperature T_s to rise above its surroundings. Substituting Eqs. (16.21) and (16.22) into (16.20) we arrive at

$$\frac{dH}{dt} = P = Ei = \delta(T_s - T_a) + C \frac{dT_s}{dt} \quad (16.23)$$

The above is a differential equation describing the thermal behavior of the thermistor. Let us now solve it for two conditions. The first condition is the constant electric power supplied to the sensor: $P = \text{const}$. Then, solution of Eq. (16.21) is

$$\Delta T = (T_s - T_a) = \frac{P}{\delta} [1 - e^{-\delta t/C}], \quad (16.24)$$

where e is the base of natural logarithms. The above solution indicates that upon applying electric power, the temperature of the sensor will exponentially rise above ambient. This specifies a transient condition which is characterized by a thermal time constant $\tau_T = C/\delta$. Here, the value of $1/\delta = \tau_T$ has a meaning of thermal resistance between the sensor and its surroundings. The exponential transient is shown in Fig. 16.8B.

Upon waiting sufficiently long to reach a steady-state level T_s , the rate of change in Eq. (16.23) becomes equal to zero ($dT_s/dt = 0$), then the rate of heat loss is equal to supplied power

$$\delta(T_s - T_a) = \delta \Delta T = V_T^2 i. \quad (16.25)$$

If by selecting low supply voltage and high resistances, the current i is made very low, temperature rise, ΔT can be made negligibly small and self-heating is virtually eliminated. Then, from Eq. (16.23)

$$\frac{dT_s}{dt} = -\frac{\delta}{C} (T_s - T_a). \quad (16.26)$$

The solution of this differential equation yields an exponential function [Eq. (16.6)], which means that the sensor responds to change in environmental temperature with time constant τ_T . Since the time constant depends on the sensor's coupling to the surroundings, it is usually specified for certain conditions, for instance, $\tau_T = 1$ s @25 °C in still air, or 0.1 s @25 °C in stirred water. It should be kept in mind, that

the above analysis represents a simplified model of the heat flows. In the reality, a thermistor response has a somewhat nonexponential shape.

All thermistor applications require the use of one of three basic characteristics:

1. The resistance vs. temperature characteristic as it is shown in Fig. 3.19. In most of the applications based on this characteristic, the self-heating effect is undesirable. Thus, the nominal resistance R_T of the thermistor should be selected high and its coupling to the object should be maximized (increase in δ). The characteristic is primarily used for sensing and measuring temperature. Typical applications are contact electronic thermometers, thermostats, and thermal breakers.
2. The current versus time (or resistance versus time) as shown in Fig. 16.8B.
3. The voltage versus current characteristic (Fig. 16.9) is important for applications where the self-heating effect is employed, or otherwise can not be neglected. The power supply-loss balance is governed by Eq. (16.25). If variations in δ are small (which is often the case) and the resistance versus temperature characteristic is known, then Eq. (16.25) can be solved for the static voltage versus current characteristic. That characteristic is usually plotted on log-log coordinates, where lines of constant resistance have a slope of +1 and lines of constant power have slope of -1 (Fig. 16.9).

At very low currents (left side of Fig. 16.9), the power dissipated by the thermistor is negligibly small, and the characteristic is tangential to a line of constant resistance of the thermistor at a specified temperature (25 °C in Fig. 16.9). Thus, the

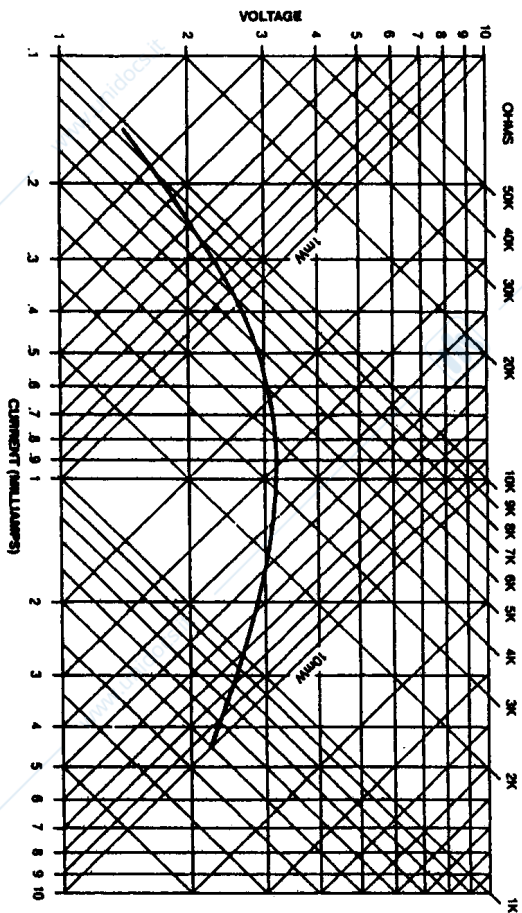

FIGURE 16.9. Voltage-current characteristic of an NTC thermistor in still air at 25 °C. (Courtesy of Thermometrics, Inc.)

thermistor behaves as a simple resistor. That is, voltage drop V_T is proportional to current i :

As the current increases, the self-heating increases as well. This results in a decrease in the resistance of the thermistor. Since the resistance of the thermistor is no longer constant, the characteristics start to depart from the straight line. The slope of the characteristic (dV_T/di), which is the resistance, drops with increase in current. The current increase leads to further resistance drop which, in turn, increases the current. Eventually, current will reach its maximum value i_p at a voltage maximum value V_p . It should be noted that, at this point, a resistance of the thermistor is zero. Further increase in current i_p will result in continuing decrease in the slope, which means that the resistance has a negative value (right side of Fig. 16.9). An even further increase in current will produce another reduction of resistance, where leadwire resistance becomes a contributing factor. A thermistor should never be operated under such conditions. A thermistor manufacturer usually specifies the maximum power rating for thermistors.

According to Eq. (16.25), self-heating thermistors can be used to measure variations in δ , ΔT , or V_T . The applications where δ varies, include vacuum manometers, anemometers, flow meters, fluid level sensors, etc. Applications where ΔT is the stimulus include microwave power meters, AFIR detectors (see below), etc. The applications where V_T varies are in some electronic circuits: automatic gain control, voltage regulation, volume limiting, etc.

PTC Thermistors

All metals may be called PTC materials, however, their temperature coefficients of resistivity (TCR) are quite low (Table A.7). In contrast, ceramic PTC materials in a certain temperature range are characterized by a very large temperature dependence. They are fabricated of polycrystalline ceramic substances, where the base compounds, usually barium titanate or solid solutions of barium and strontium titanate (highly resistive materials) made semiconductive by the addition of dopants [3]. Above the Curie temperature of a composite material, the ferroelectric properties change rapidly resulting in a rise in resistance, often several orders of magnitude. A typical transfer function curve for the PTC thermistor is shown in Fig. 16.10 in a comparison with the NTC and RTD responses. The shape of the curve does not lend itself to easy mathematical approximation, therefore, manufacturers usually specify PTC thermistors by a set of numbers:

1. Zero power resistance, R_{25} , at 25 °C, where self-heating is negligibly small;
2. Minimum resistance R_m is the value on the curve where thermistor changes its TCR from positive to negative value (point m);
3. Transition temperature T_T is the temperature where resistance begins to change rapidly. It coincides approximately with the Curie point of the material. A typical range for the transition temperatures is from -30 to +160 °C (Keystone Carbon Co.);
4. TCR is defined in a standard form

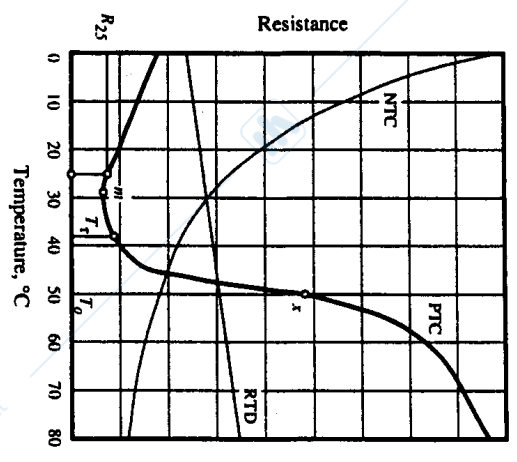

FIGURE 16.10. Transfer functions of PTC and NTC thermistors as compared with RTD.

$$\alpha = \frac{1}{R} \cdot \frac{\Delta R}{\Delta T} \quad (16.27)$$

- The coefficient changes very significantly with temperature and often is specified at point x , that is, at its highest value, which may be as large as 2%/°C (meaning the change in resistance is 200% per °C);
- Maximum voltage E_{max} is the highest value which the thermistor can withstand at any temperature;
 - Thermal characteristics are specified by a thermal capacity, a dissipation constant δ (specified under given conditions of coupling to the environment) and a thermal time constant (defines speed response under specified conditions).

It is important to understand that for the PTC thermistors two factors play a key role: environmental temperature and a self-heating effect. Either one of these two factors shifts the thermistor's operating point.

The temperature sensitivity of the PTC thermistor is reflected in a volt-ampere characteristic of Fig. 16.11. A regular resistor with the near zero TCR, according to Ohm's law, has a linear characteristic. A NTC thermistor has a positive curvature of the volt-ampere dependence. An implication of the negative TCR is that if such a thermistor is connected to a hard voltage source, a self-heating due to Joule heat dissipation will result in resistance reduction. In turn, that will lead to further increase in current and more heating. If the heat outflow from the NTC thermistor

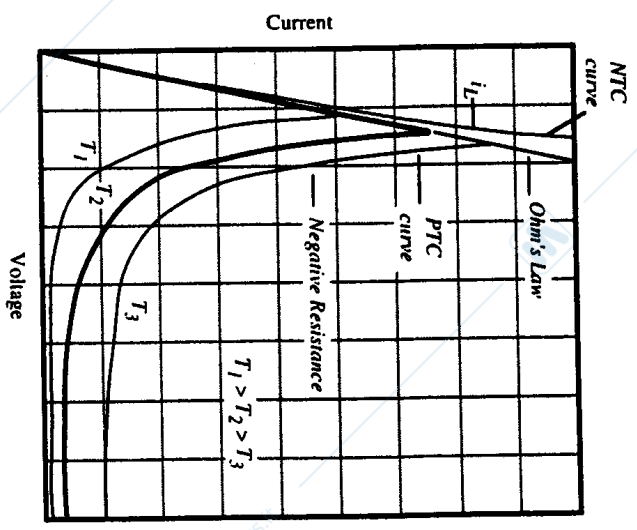

FIGURE 16.11. Volt-ampere characteristic of a PTC thermistor.

is restricted, a self-heating may eventually cause overheating and a catastrophic destruction of the device.

Thanks to positive TCRs, metals do not overheat when connected to hard voltage sources and behave as self-limiting devices. For instance, a filament in an incandescent lamp does not burn out because the increase in its temperature results in an increase in resistance which limits current. This self-limiting (self-regulating) effect is substantially enhanced in the PTC thermistors. The shape of the volt-ampere characteristic indicates that in a relatively narrow temperature range the PTC thermistor possesses a negative resistance, that is

$$R_x = -\frac{V_x}{I} \quad (16.28)$$

This results in the creation of an internal negative feedback which makes this device a self-regulating thermostat. In the region of negative resistance, any increase in voltage across the thermistor results in heat production which, in turn, increases the resistance and reduces heat production. As a result, the self-heating effect in a PTC thermistor produces enough heat to balance the heat loss on such a level that it maintains the device's temperature on a constant level T_0 (Fig. 16.10). That temperature corresponds to point x where tangent to the curve has the highest

⁴A hard voltage source means any voltage source having a near zero output resistance and capable of delivering unlimited current without a change in voltage.

It should be noted that PTC thermistors are much more efficient when T_o is relatively high (over 100 °C) and their efficiency (the slope of the R - T curve near point x) drops significantly at lower temperatures. By their very nature, PTC thermistors are useful in the temperature range which is substantially higher than the operating ambient temperature.

There are several applications where the self-regulating effect of a PTC thermistor may be quite useful. We briefly mention four of them.

1. Circuit protection. A PTC thermistor may operate as a nondestructible (resettable) fuse in electric circuits, sensing excessive currents. Figure 16.12A shows a PTC thermistor connected in series with a power supply voltage E feeding the load with current i . The resistance of the thermistor at room temperature is quite low (typically from 10 to 140 Ω). Current i develops voltage V_L across the load and voltage V_x across the thermistor. It is assumed that $V_L \gg V_x$. Power dissipated by the thermistor $P = V_x i$, is lost to the surroundings and the thermistor's temperature is raised above ambient by a relatively small value. Whenever either ambient temperature becomes too hot, or load current increases dramatically (for instance, due to internal failure in the load), the heat dissipated by the thermistor elevates its temperature to a T_r region where its resistance starts increasing. This limits further current increase. Under the shorted-load conditions, $V_x = E$ and current i drops to its minimal level. This will be maintained until normal resistance of the load is restored and, it is said, that the fuse resets itself. It is important to assure that $E < 0.9E_{max}$ otherwise a catastrophic destruction of the thermistor may occur.

2. A miniature self-heating thermostat (Fig. 16.12B) for the microelectronic, biomedical, chemical, and other suitable applications can be designed with a single PTC thermistor. Its transition temperature must be appropriately selected. A thermostat consists of a dish, which is thermally insulated from the environment and thermally coupled to the thermistor. Thermal grease is recommended to eliminate a dry contact. The terminals of the thermistor are connected to a voltage source whose value may be estimated from the following formula

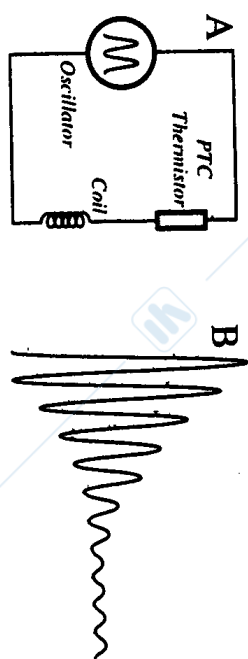
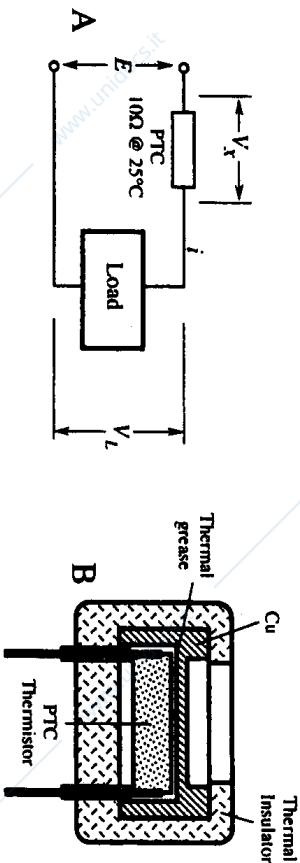

FIGURE 16.13. A demagnetization device with a PTC thermistor attenuator. A: A circuit diagram; B: current through the coil.

$$E \approx 2\sqrt{\delta(T_r - T_o)R_{25}} \quad (16.29)$$

where δ is the heat dissipation constant which depends on thermal coupling to the environment and T_o is ambient temperature. The thermostat's set point is determined by the physical properties of the ceramic material (Curie temperature) and due to internal thermal feedback, the device reliably operates within relatively large range of power supply voltages and ambient temperatures. Naturally, ambient temperature must be always less than T_r .

3. Time delay circuits can be created with the PTC thermistors thanks to a relatively long transition time between the application of electric power in its heating to a low resistance point. Figure 16.13 shows a simple demagnetization device where electric current in a coil and the corresponding magnetic field decline in magnitude as the PTC thermistor warms up. When the oscillator is turned off, the thermistor is cold and its resistance is low. Upon turning the oscillator on, current through the coil warms up the thermistor resulting in a gradual increase in its temperature. This, in turn, increases its resistance thus reducing the current.

4. Flowmeter and liquid level detectors which operate on principle of heat dissipation can be made very simple with the PTC thermistors (Sec. 10.3).

16.2 THERMOELECTRIC CONTACT SENSORS

Thermoelectric contact sensors are called *thermocouples* because at least two dissimilar conductors are required to make a sensor. Section 3.9 provides a physical background for a better understanding of their operation and Table A.10 lists some popular thermocouples which are designated by letters originally assigned by the Instrument Society of America (ISA) and adopted by an American Standard in ANSI MC 96.1. A detailed description of various thermocouples and their applications can be found in many excellent texts, for instance in [1,4,5]. Below, we summarize the most important recommendations for the use if these sensors.

Type T: Cu (+) versus constantan (-) are resistant to corrosion in moist atmosphere and are suitable for subzero temperature measurements. Their use in air in oxidizing environment is restricted to 370 °C (700 °F) due to oxidation of the

copper thermoelement. They may be used to higher temperatures in some other atmospheres.

Type J: Fe (+) versus constantan (-) are suitable in vacuum and in oxidizing, reducing, or inert atmospheres, over the temperature range of 0 to 760 °C (32 to 1400 °F). The rate of oxidation in the iron thermoelement is rapid above 540 °C (1000 °F), and the use of heavy-gage wires is recommended when long life is required at the higher temperatures. This thermocouple is not recommended for use below the ice point because rusting and embrittlement of the iron thermoelement make its use less desirable than Type T.

Type E: 10% Ni/Cr (+) versus constantan (-) are recommended for use over the temperature range of -200 to 900 °C (-330 to 1600 °F) in oxidizing or inert atmospheres. In reducing atmospheres, alternately oxidizing or reducing atmospheres, marginally oxidizing atmospheres, and in vacuum, they are subject to the same limitations as type K. These thermocouples are suitable to subzero measurements since they are not subject to corrosion in atmospheres with a high moisture content. They develop the highest e.m.f. per degree of all the commonly used types and are often used primarily because of this feature (see Fig. 3.36).

Type K: 10% Ni/Cr (+) versus 5% Ni/Al/Si (-) are recommended for use in an oxidizing or completely inert atmosphere over a temperature range of -200 to 1260 °C (-330 to 2300 °F). Due to their resistance to oxidation, they are often used at temperatures above 540 °C. However, type K should not be used in reducing atmospheres, in sulfurous atmospheres, and in a vacuum.

Types R and S: Pt/Rh (+) versus Pt (-) are recommended for continuous use in oxidizing or inert atmospheres over a temperature range of 0 to 1480 °C (32 to 2700 °F).

Type B: 30% Pt/Rh (+) versus 6% Pt/Rh (-) are recommended for continuous use in oxidizing or inert atmospheres over the range of 870 to 1700 °C (1000 to 3100 °F). They are also suitable for short-term use in a vacuum. They should not be used in reducing atmospheres, nor those containing metallic or nonmetallic vapors. They should never be directly inserted into a metallic primary protecting tube or well.

For practical purposes, an application engineer must be concerned with three basic laws which establish the fundamental rules for proper connection of the thermocouples. It should be stressed, however, that an electronic interface circuit must always be connected to two identical conductors. These conductors may be formed from one of the thermocouple loop arms. That arm is broken to connect the metering device to the circuit. The broken arm is indicated as material A in Fig. 16.14A.

LOW NO. 1

A thermoelectric current can not be established in a homogeneous circuit by heat alone. This law provides that a nonhomogeneous material is required for the generation of the Seebeck potential. If a conductor is homogeneous, regardless of the

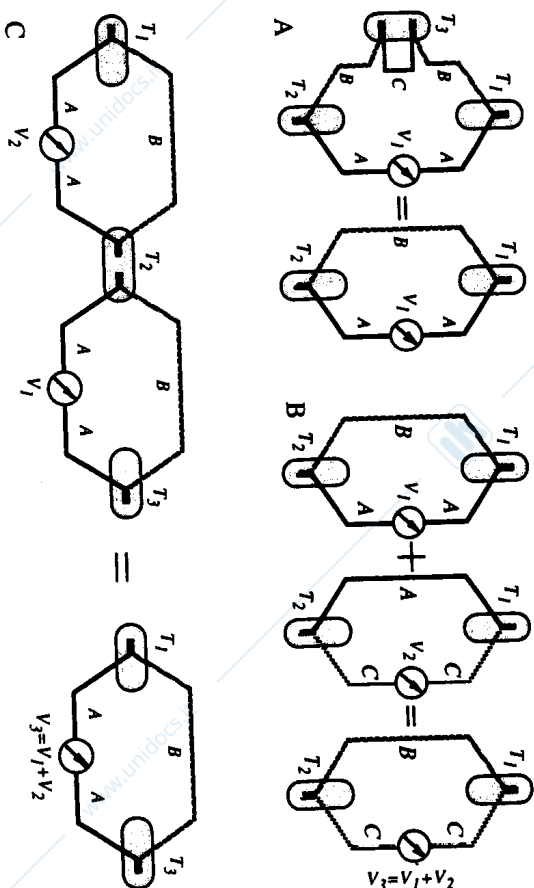

FIGURE 16.14. Illustrations for or the laws of thermocouples (see text).

temperature distribution along its length, the resulting voltage is zero. The junction of two dissimilar conductors provide a condition for voltage generation.

LOW NO. 2

The algebraic sum of the thermoelectric forces in a circuit composed of any number and combination of dissimilar materials is zero if all junctions are at a uniform temperature. The law provides that an additional material C can be inserted into any arm of the thermoelectric loop without affecting the resulting voltage V_1 as long as both additional joints are at the same temperature (T_3 in Fig. 16.14A). There is no limitation on the number of inserted conductors, as long as both contacts for each insertion are at the same temperature. This implies that an interface circuit must be attached in such a manner as to assure a uniform temperature for both contacts. Another consequence of the law is that thermoelectric joints may be formed by any technique, even if an additional intermediate material is involved (like, solder, for instance). The joints may be formed by welding, soldering, twisting, fusion, and so on without affecting the accuracy of the Seebeck voltage. The law also provides a rule of *additive materials* (Fig. 16.14B): if thermoelectric voltages (V_1 and V_2) of two conductors (B and C) with respect to a reference conductor (A) are known, the voltage of a combination of these two conductors is the algebraic sum of their voltages against the reference conductor.

LOW NO. 3

If two junctions at temperatures T_1 and T_2 produce Seebeck voltage V_2 , and temperatures T_2 and T_3 produce voltage V_1 , then temperatures T_1 and T_3 will produce $V_3 = V_1 + V_2$ (Fig. 16.14C). This is sometimes called the law of intermediate temperatures. The law allows us to calibrate a thermocouple at one temperature interval and then to use it at another interval. It also provides that extension wires of the same combination may be inserted into the loop without affecting the accuracy.

The above laws provide for numerous practical circuits where thermocouples can be used in a great variety of combinations. They can be arranged to measure the average temperature of an object, to measure the differential temperature between two objects, and to use other than thermocouple sensors for the reference junctions, etc.

It should be noted that thermoelectric voltage is quite small and the sensors, especially with long connecting wires are susceptible to various transmitted interferences. A general guideline for the noise reduction may be found in Sec. 4.9.

Figure 16.15A shows an equivalent circuit for a thermocouple and a thermopile. It consists of a voltage source and a serial resistor. The voltage source represents the Seebeck voltage whose magnitude is a function of a temperature differential. The terminals of the circuit are assumed being fabricated of the same material, copper in this example.

Traditionally, thermocouples were used with a cold junction immersed into a reference ice bath to maintain its temperature at 0 °C. This presents serious limitations for many practical uses. The second and third thermoelectric laws provided above allow for a simplified solution. A "cold" junction can be maintained at any temperature, including ambient, as long as that temperature is precisely known. Therefore, a "cold" junction is thermally coupled to an additional temperature sensor which does not require a reference compensation. Usually, such a sensor is either thermoresistive or semiconductor.

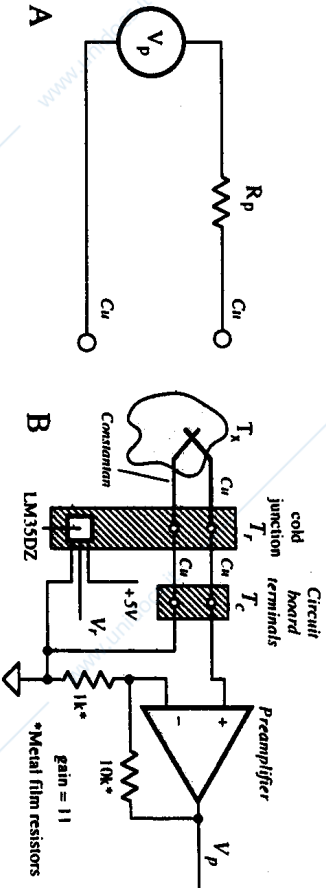

FIGURE 16.15. Use of a thermocouple. A: An equivalent circuit of a thermocouple. B: a front end of a thermocouple with a semiconductor reference sensor (LM35DZ).

Figure 16.15B shows the correct connection of a thermocouple to an electronic circuit and a "cold" junction reference sensor. Both the "cold" junction and the reference sensor must be positioned in intimate thermal coupling. Usually, they are imbedded into a chunk of copper. To avoid dry contact, thermally conductive grease or epoxy should be applied for better thermal tracking. A reference temperature detector in this example is a semiconductor sensor LM35DZ manufactured by National Semiconductor, Inc. The circuit has two outputs—one for the signal representing the Seebeck voltage V_p and the other for the reference signal V_r . The schematic illustrates that connections to the circuit board input terminals and then to the amplifier's noninverting input and to the ground bus is made by the same type of wires (Cu). However, input terminals of the board not necessarily have to be at the "cold" junction temperature. It is especially important for the remote measurements, where circuit board temperature T_c may be different from the "cold" junction temperature T_r .

A complete thermocouple sensing assembly generally consists of one or more of the following: a sensing element assembly (the junction), a protective tube (ceramic or metal jackets), a thermowell (for some critical applications these are drilled solid bar stocks which are made to precise tolerances and are highly polished to inhibit corrosion), terminations (contacts which may be in the form of a screw type, open type, plug and jack-disconnect, military standard type connectors, etc.). Some typical thermocouple assemblies are shown in Fig. 16.16. The wires may be left bare, or given electrical isolators. For the high temperature applications, the isolators may be of a fish-spine or ball ceramic type, which provide sufficient flexibility. If thermocouple wires are not electrically isolated, a measurement error may occur.

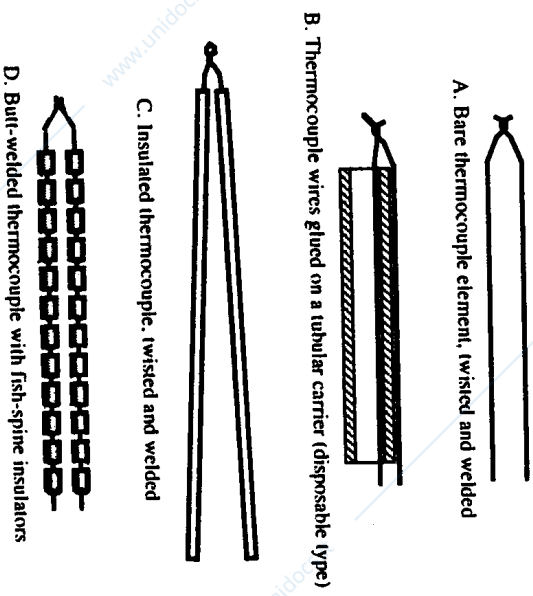

FIGURE 16.16. Some thermocouple assemblies.

Insulation is affected adversely by moisture, abrasion, flexing, temperature extremes, chemical attack, and nuclear radiation. A good knowledge of particular limitations of insulating materials is essential for accurate and reliable measurement. Some insulations have a natural moisture resistance: Teflon[®], polyvinyl chloride (PVC), and some forms of polyimides are examples of this group. With the fiber type insulations, moisture protection results from impregnating with substances such as wax, resins, or silicone compounds. It should be noted that only one-time exposure to over-extreme temperatures causes evaporation of the impregnating materials and loss of protection.

The moisture penetration is not confined to the sensing end of the assembly. For example, if a thermocouple passes through hot or cold zones, condensation may produce errors in the measurement, unless adequate moisture protection is provided.

The basic types of flexible insulations for elevated temperature usage are fiberglass, fibrous silica, and asbestos (which should be used with proper precaution due to health hazard). In addition, thermocouples must be protected from atmospheres that are not compatible with the alloys. Protecting tubes serve the double purpose of guarding the thermocouple against mechanical damage and interposing a shield between the wires and the environment. The protecting tubes can be made of carbon steels (up to 540 °C in oxidizing atmospheres), stainless steel (up to 870 °C), ferric stainless steel (AISI 400 series), high-nickel alloys, Nichrome,⁵ Inconel,⁶ etc. (up to 1150 °C in oxidizing atmospheres).

Practically all base-metal thermocouple wires are annealed or given a "stabilizing heat treatment" by the manufacturer. Such treatment generally is considered sufficient, and seldom it is found advisable to further anneal the wire before testing or using. Although a new platinum and platinum-rhodium thermocouple wire, as sold by some manufacturers, already is annealed, it has become a regular practice in many laboratories to anneal all types *R*, *S*, and *B* thermocouples, whether new or previously used, before attempting an accurate calibration. This is accomplished usually by heating the thermocouple electrically in air. The entire thermocouple is supported between two binding posts, which should be close together, so that the tension in the wires and stretching while hot are kept at a minimum. The temperature of the wire is conveniently determined with an optical pyrometer. Most of the mechanical strains are relieved during the first few minutes of heating at 1400 to 1500 °C.

Thin film thermocouples are formed by bonding junctions of foil metals. They are available in a free filament style with a removable carrier and in a matrix style with a sensor embedded in a thin laminated material. The foil having a thickness in the order of 5 μm (0.0002") gives an extremely low mass and thermal capacity. Thin flat junctions may provide intimate thermal coupling with the measured surface. Foil thermocouples are very fast (a typical thermal time constant is 10 ms), and can be used with any standard interface electronic apparatuses. While measuring

temperature with sensors having small mass, thermal conduction through the connecting wires always must be accounted for. Thanks to a very large length to thickness ratio of the film thermocouples (on the order of 1000) heat loss via wires usually is negligibly small.

To attach a film thermocouple to an object, several methods are generally used. Among them are various cements and flame or plasma sprayed ceramic coatings. For ease of handling, the sensors often are supplied on a temporary carrier of polyimide film which is tough, flexible, and dimensionally stable. It is exceptionally heat resistant and inert. During the installation, the carrier can be easily plied off or released by application of heat. The free foil sensors can be easily brushed into a thin layer, to produce an ungrounded junction. While selecting cements, care must be taken to avoid corrosive compounds. For instance, cements containing phosphoric acid are not recommended for use with thermocouples having copper in one arm.

16.3 SEMICONDUCTOR PN-JUNCTION SENSORS

A semiconductor *pn*-junction in a diode and a bipolar transistor exhibits quite a strong thermal dependence. If the junction is connected to a constant current generator (Sec. 4.3.1), the resulting voltage becomes a measure of the junction temperature. A very attractive feature of such a sensor is its high degree of linearity (Fig. 16.17). This allows a simple method of calibration using just two points to define a slope (sensitivity) and an intercept.

The current-to-voltage *V* equation of a *pn*-junction diode (Fig. 16.18A) can be expressed as

$$I = I_0 \exp(qV/2kT), \quad (16.30)$$

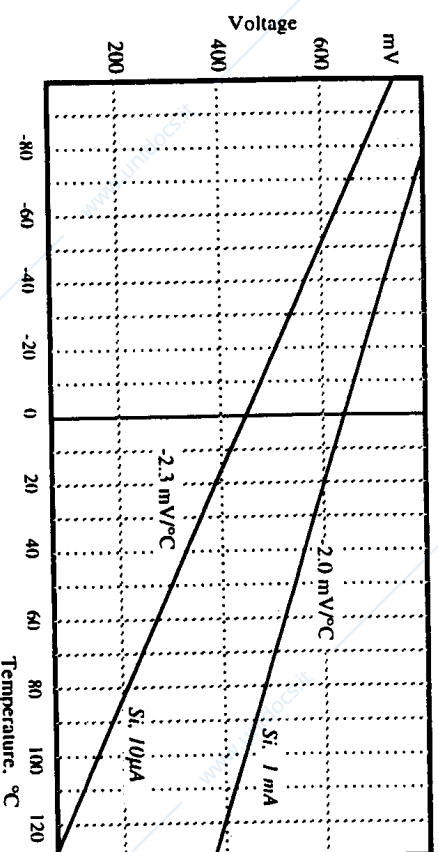

FIGURE 16.17. Voltage-to-temperature dependence of a forward biased semiconductor junction under constant current conditions.

⁵Trademark of the Driver-Harris Company.

⁶Trademark of the International Nickel Company.

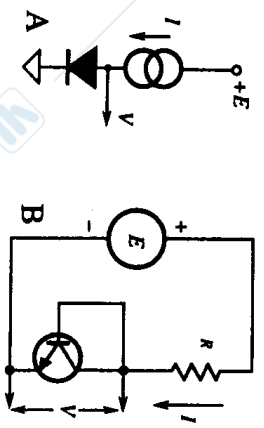

FIGURE 16.18. Forward biased pn-junction temperature sensors. A: a diode; B: a diode-connected transistor.

where I_o is the saturation current, which itself is a strong function of temperature. It can be shown that the temperature-dependent voltage across the junction can be expressed as

$$V = \frac{E_g}{q} - \frac{2kT}{q} (\ln K - \ln I), \tag{16.31}$$

where E_g is the energy band gap for silicon at 0 K (absolute zero), q is the charge of an electron and K is a temperature independent constant. It follows from the above equation that when the junction is operated under constant current conditions, the voltage is linearly related to the temperature, and the slope is given by

$$b = \frac{dV}{dT} = -\frac{2k}{q} (\ln K - \ln I). \tag{16.32}$$

Typically, for a silicon junction operating at 10 μA , the slope (sensitivity) is approximately $-2.3 \text{ mV}/^\circ\text{C}$ and it drops to about $-2.0 \text{ mV}/^\circ\text{C}$ for a 1 mA current. While any diode or transistor can be used as a temperature sensor, special devices are available for that particular purpose. An example is a sensor MTS102 from Motorola Semiconductor Products, Inc. A practical circuit for the transistor used as a temperature sensor is shown in Fig. 16.18B. A voltage source E and a stable resistor R is used instead of a current source. Current through the transistor is determined as

$$I = \frac{E - V}{R}. \tag{16.33}$$

It is recommended to use current on the order of $I = 100 \mu\text{A}$, therefore for $E = 5 \text{ V}$ and $R \approx 0.6 \text{ k}\Omega$, the resistor $R = (E - V)/I = 44 \text{ k}\Omega$. When the temperature increases, voltage V drops which results in a minute increase in current I . According to Eq. (16.32), this causes some reduction in sensitivity which, in turn,

is manifested as nonlinearity. However, the nonlinearity may be either small enough for a particular application, or it can be taken care of during signal processing. This makes a transistor (a diode) temperature sensor a very attractive device for many applications, due to its simplicity and low cost. Figure 16.19 shows an error curve for the temperature sensors made with the PN100 transistor operating at 100 μA . It is seen that the error is quite small and for many practical purposes no linearity correction is required.

A diode sensor can be formed in a silicon substrate in many monolithic sensors which require temperature compensation. For instance, it can be diffused into a micromachined membrane of a silicon pressure sensors to compensate for temperature dependence of piezoresistive elements.

An inexpensive, yet precision semiconductor temperature sensor may be fabricated by using fundamental properties of transistors to produce voltage which is proportional to absolute temperature (in K). That voltage can be used directly or it can be converted into current [6]. The relationship between base-emitter voltage (V_{be}) and collector current of a bipolar transistor is the key property to produce a linear semiconductor temperature sensor. Figure 16.20A shows a simplified circuit where Q_3 and Q_4 form the so-called current mirror. It forces two equal currents $I_{C1} = I$ and $I_{C2} = I$ into transistors Q_1 and Q_2 . The collector currents are determined by resistor R . In a monolithic circuit, transistor Q_2 is actually made of several identical transistors connected in parallel, for example, 8. Therefore, the current density in Q_1 is 8 times higher than that of each of transistors Q_2 . The difference between base emitter voltages of Q_1 and Q_2 is

$$\Delta V_{be} = V_{be1} - V_{be2} = \frac{kT}{q} \ln \left(\frac{rI}{I_{ceo}} \right) - \frac{kT}{q} \ln \left(\frac{I}{I_{ceo}} \right) = \frac{kT}{q} \ln r, \tag{16.34}$$

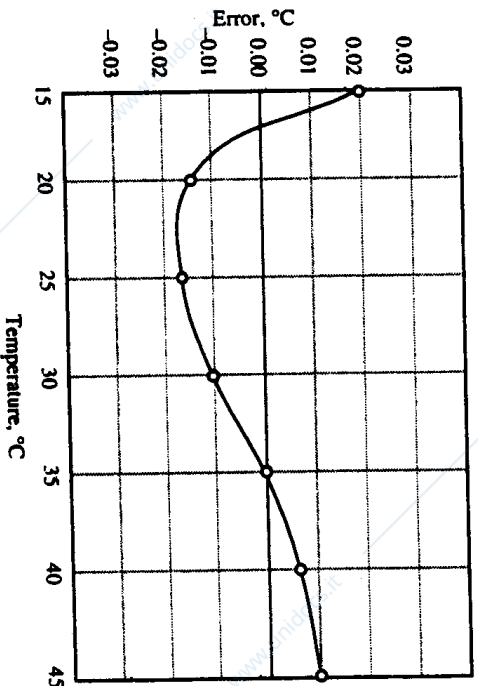

FIGURE 16.19. An error curve for a silicon transistor (PN100) as a temperature sensor.

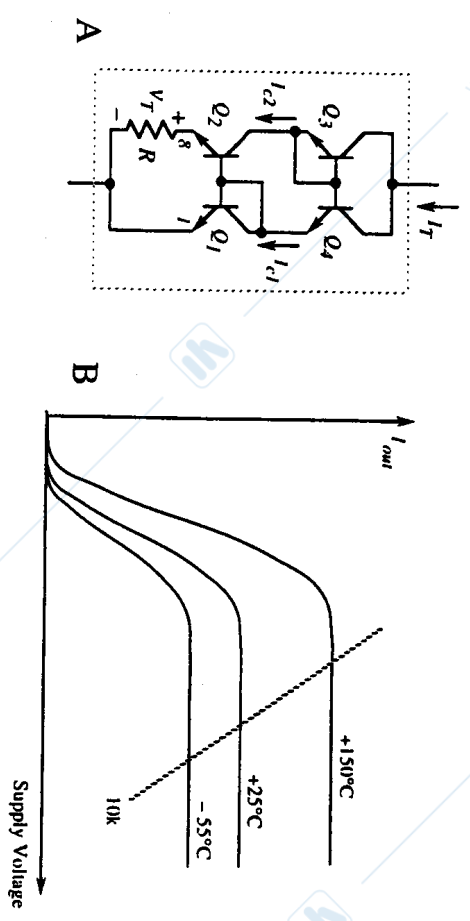

FIGURE 16.20. Simplified circuit for a semiconductor temperature sensor (A) and current-to-voltage curves (B).

where r is a current ratio (equal to 8 in our example), k is the Boltzmann constant, q is the charge of an electron and T is the temperature in K. Currents $I_{e^{vo}}$ are the same for both transistors. As a result, a current across resistor R produces voltage $V_T = 179 \mu\text{V} \cdot T$ which is independent on the collector currents. Therefore, the total current through the sensor is

$$I_T = 2 \frac{V_T}{R} = \left(2 \frac{k}{qR} \ln r \right) T, \quad (16.35)$$

which for currents ratio $r=8$ and resistor $R=358 \Omega$ produces a linear transfer function $I_T/T=1 \mu\text{A}/^\circ\text{K}$.

Figure 16.20B shows current-to-voltage curves for different temperatures. Note that the value in parenthesis of Eq. (16.35) is constant for a particular sensor design and may be precisely trimmed during the manufacturing process for a desired slope I_T/T . Current I_T may be easily converted into voltage. If, for example, a $10 \text{ k}\Omega$ resistor is connected in series with the sensor, the voltage across that resistor will be a linear function of absolute temperature.

The simplified circuit of Fig. 16.20A will work according to the above equations only with perfect transistors ($\beta=\infty$). Practical monolithic sensors contain many additional components to overcome limitations of the real transistors. Several companies produce temperature sensors based on this principle. Examples are LM35 from National Semiconductors (voltage output circuit) and AD590 from Analog Devices (current output circuit).

Figure 16.21 shows a transfer function of a LM35Z temperature sensor which has a linear output internally trimmed for the Celsius scale with a sensitivity of 10 mV

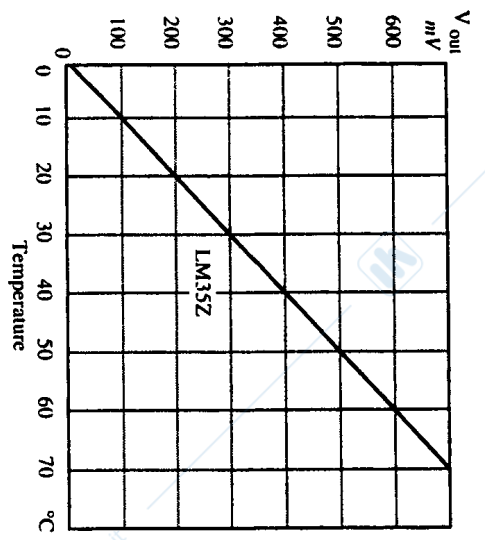

FIGURE 16.21. A typical transfer function of a LM35Z semiconductor temperature sensor (from National Semiconductors, Inc.).

per $^\circ\text{C}$. The function is quite linear where the nonlinearity error is confined within $\pm 0.1^\circ$. The function can be modeled by

$$V_{out} = V_o + aT, \quad (16.36)$$

where T is the temperature in degrees C. Ideally, V_o should be equal to zero, however part-to-part variations of its value may be as large as $\pm 10 \text{ mV}$ which correspond to an error of 1°C . Slope a may vary between 9.9 and $10.1 \text{ mV}/^\circ\text{C}$.

16.4 OPTICAL TEMPERATURE SENSORS

Sometimes, temperatures have to be measured at tough hostile environments when very strong electrical, magnetic or electromagnetic fields, or very high voltages make measurements either too susceptible to interferences, or too dangerous for the operator. One way to solve the problem is to use noncontact methods of temperature measurements, such as described in Sec. 13.7.

However, there are also contact optical sensors which can sense temperature and transmit information without a need for any electronic devices at the measurement site.

16.4.1 Fluoroptic Sensors

These sensors rely on the ability of a special phosphor compound to give away a fluorescent signal in response to light excitation. The shape of the response pulse is a function of temperature. The decay of the response pulse relaxation is highly

reproducible over a wide temperature range [7]. As a sensing material, magnesium fluoromagnetic activated with tetravalent manganese is used. This is phosphor, long known in the lighting industry as a color corrector for mercury vapor street lamps, prepared as a powder by a solid-state reaction at approximately 1200 °C. It is thermally stable, relatively inert and benign from a biological standpoint, and insensitive to damage by most chemicals or by prolonged exposure to ultraviolet (UV) radiation. It can be excited to fluoresce by either UV or blue radiation. Its fluorescent emission is in the deep red region, and the fluorescent decay is essentially exponential.

To minimize crosstalk between the excitation and emission signals, they are passed through the bandpass filters which reliably separate the related spectra (Fig. 16.22A). The pulsed excitation source, a Xenon flash lamp, can be shared among a number of optical channels in a multisensor system. The temperature measurement is made by measuring the rate of decay of the fluorescence, as shown in Fig. 16.22B. That is, a temperature is represented by a time constant τ which drops fivefold over the temperature range from -200 to +400 °C. The measurement of time is usually the simplest and most precise operation that can be performed by an electronic circuit, thus, temperature can be measured with a good resolution and accuracy: about ± 2 °C over the range without calibration.

Since the time constant is independent of excitation intensity, a variety of designs is possible. For instance, the phosphor compound can be directly coated onto the surface of interest and the optic system can take measurement without a physical contact (Fig. 16.23A). This makes possible continuous temperature monitoring without disturbing a measured site. In another design, a phosphor is coated on the tip of a pliable probe which can form a good contact area when brought in contact with the object (Fig. 16.23B and C).

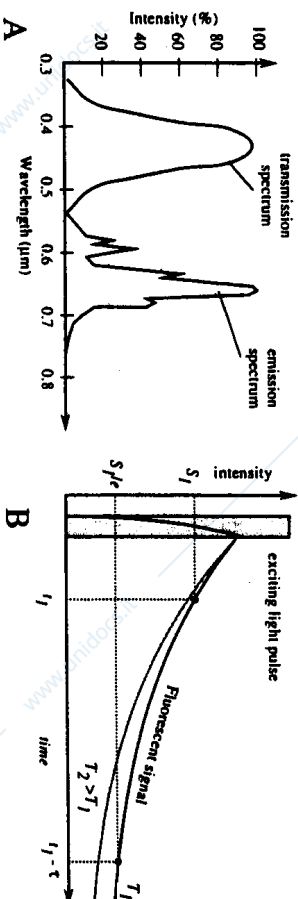

FIGURE 16.22. Fluoroptic method of temperature measurement. A: spectral responses of the excitation and emission signals. B: exponential decay of the emission signal for two temperatures (T_1 and T_2); e is the base of natural logarithms, and τ is a decay time constant (adapted from [7]).

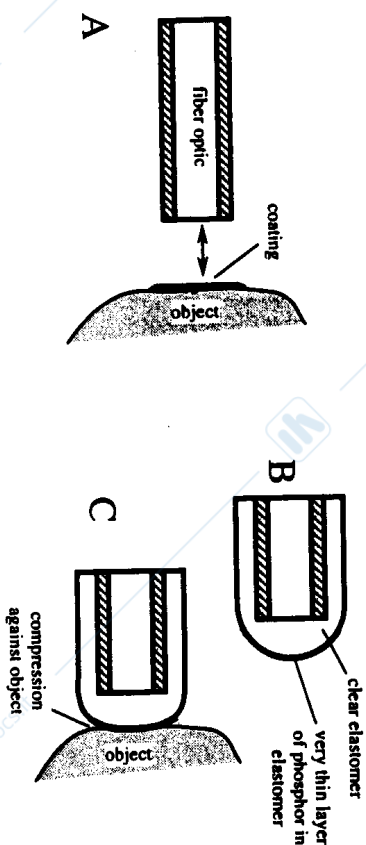

FIGURE 16.23. Placement of a phosphor compound in fluoroptic method. A: On the surface of an object; B and C: on the tip of the probe (adapted from [7]).

16.4.2 Interferometric Sensors

Another method of temperature measurement is based on the modulation of light intensity by interfering two light beams. One beam is a reference, while the other's travel through a temperature sensitive medium is somewhat delayed depending on temperature. This results in a phase shift and a subsequent extinction of the interference signal. A similar principle was described in more detail in Sec. 9.8. For temperature measurement, a thin layer of silicon [8,9] can be used because its refractive index changes with temperature, thus modulating a light travel distance.

Figure 16.24 shows a schematic of a thin film optical sensor. The sensor was fabricated by sputtering of three layers onto the ends of the step-index multimode fibers with 100 μm core diameters and 140 μm cladding diameters [10]. The first layer is silicone, then silicon dioxide. The FeCrAl layer on the end of the probe prevents oxidation of the underlying silicon. The fibers can be used up to 350 °C, however much more expensive fibers with gold buffered coatings can be used up to 650 °C. The sensor is used with LED light source operating in the range of 860 nm and a micro-optic spectrometer. A useful instrument for measurements of fiber-optic interference signals is a fiber-optic refractometer. One such instrument (Model 1430) is produced by MetriCor Inc., Woodinville, WA.

16.4.3 Thermochromic Solution Sensors

For biomedical applications, where electromagnetic interferences may present a problem, a temperature sensor can be fabricated with use of a thermochromic solution [11], such as cobalt chloride ($\text{CoCl}_2 \cdot 6\text{H}_2\text{O}$).

The operation of this sensor is based on the effect of a temperature dependence of a spectral absorption in the visible range of 400–800 nm by the thermochromic solution (Fig. 16.25A). This implies that the sensor should consist of a light source,

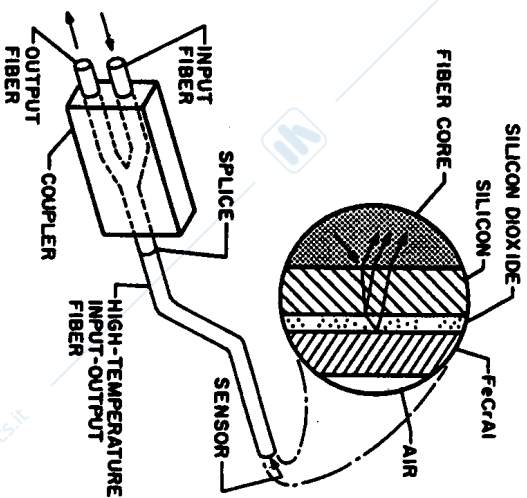

FIGURE 16.24. A schematic of a thin film optical temperature sensor. (Reprinted with permission, Sensors Magazine, © 1990.)

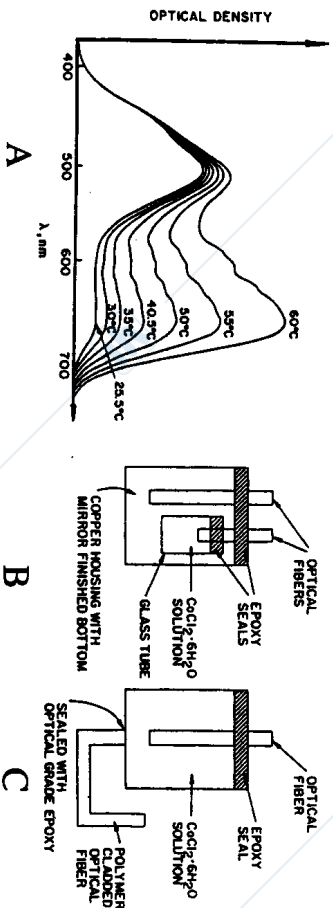

FIGURE 16.25. A thermochromic solution sensor. A: Absorption spectra of the cobalt chloride solution; B: reflective fiber coupling; C: transmissive coupling. (From [11].)

a detector, and a cobalt chloride solution which is thermally coupled with the object. Two possible designs are shown in Figs. 16.25B and C, where transmitting and receiving optical fibers are coupled through a cobalt chloride solution.

16.5 ACOUSTIC TEMPERATURE SENSORS

Under extreme conditions, temperature measurement may become a difficult task. These conditions include a cryogenic temperature range, high radiation levels inside

nuclear reactors, etc. Another unusual condition is the temperature measurement inside a sealed enclosure with a known medium, in which no contact sensors can be inserted and the enclosure is not transmissive for the infrared radiation. Under such unusual conditions, acoustic temperature sensors may come in quite handy. An operating principle of such a sensor is based on a relationship between temperature of the medium and speed of sound. For instance, in dry air at a normal atmospheric pressure the relationship is

$$c \approx 331.5 \sqrt{\frac{T}{273.15}} \text{ m/sec,} \quad (16.37)$$

where c is the speed of sound and T is the absolute temperature.

An acoustic temperature sensor (Fig. 16.26) is composed of three components: an ultrasonic transmitter, an ultrasonic receiver, and a gas-filled hermetically sealed tube. The transmitter and receiver are ceramic piezoelectric plates which are acoustically decoupled from the tube to assure sound propagation primarily through the enclosed gas, which in most practical cases is dry air. Alternatively, the transmitting and receiving crystals may be incorporated into a sealed enclosure with a known content whose temperature has to be measured. That is, an intermediate tube is not necessarily required in cases where the internal medium, its volume and mass are held constant. When a tube is used, care should be taken to prevent its mechanical deformation and loss of hermeticity under the extreme temperature conditions. A suitable material for the tube is invar.

The clock of a low frequency (near 100 Hz) triggers the transmitter and disables the receiver. The piezoelectric crystal flexes transmitting an ultrasonic wave along the tube. The receiving crystal is enabled before the wave arrives to its surface and converts it into an electrical transient, which is amplified and sent to the control circuit. The control circuit calculates the speed of sound by determining propagation time along the tube. Then, the corresponding temperature is determined from the calibration numbers stored in a look-up table. In another design, the thermometer

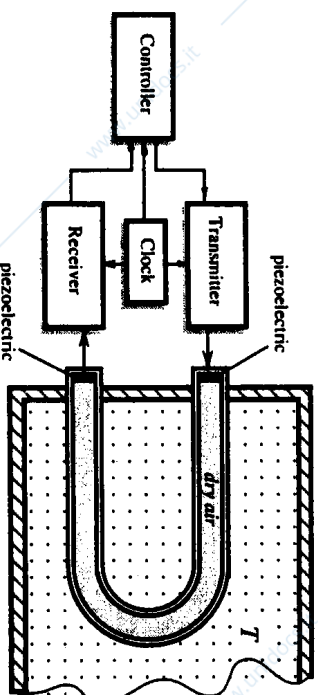

FIGURE 16.26. An acoustic thermometer with an ultrasonic detection system.

may contain only one ultrasonic crystal which alternately acts either as a transmitter, or as a receiver. In that case, the tube has a sealed empty end. The ultrasonic waves are reflected from the end surface and propagate back to the crystal, which before the moment of the wave arrival is turned into a reception mode. An electronic circuit [12] converts the received pulses into a signal which corresponds to the tube temperature.

A miniature temperature sensor can be fabricated with the surface acoustic waves (SAW) and plate waves (PW) techniques (see Chap. 11). The idea behind such a sensor is in temperature modulation of some mechanical parameters of a time-keeping element in the electronic oscillator [13,14]. This leads to the change in the oscillating frequency. In effect, such an integral acoustic sensor becomes a direct converter of temperature into frequency. A typical sensitivity is in the range of several kilohertz per degree Kelvin.

16.6 PIEZOELECTRIC TEMPERATURE SENSORS

Piezoelectric effect, in general, is a temperature dependent phenomenon. Thus, a temperature sensor based on variability of oscillating frequency of a quartz crystal can be designed. Since the quartz is an anisotropic medium, the resonant frequency of a plate is highly dependent on the crystallographic orientation of the plate—the so-called angle of cut. Thus, by selecting a cut, a negligibly small temperature sensitivity may be achieved (AT - and BT -cuts). Temperature dependence of the resonant frequency may be approximately by a 3-rd order polynomial

$$\frac{\Delta f}{f_0} = a_0 + a_1 \Delta T + a_2 \Delta T^2 + a_3 \Delta T^3 \quad (16.38)$$

where ΔT and Δf are the temperature and frequency shifts respectively, f_0 is the calibrating frequency and a are the coefficients. The first utilization of temperature dependence was made in 1962 by utilizing a non-rotated Y -cut crystal [15]. A very successful development of a linear temperature coefficient-cut (LC) was made by Hewlett-Packard [16]. The 2-nd and 3-rd order coefficients had been eliminated by selecting a doubly-rotated Y -cut. The sensitivity (a_1) of the sensor is 35 ppm $^{\circ}\text{C}^{-1}$ and the operating temperature range is from -80 to 230 $^{\circ}\text{C}$ with calibration accuracy of 0.02 $^{\circ}\text{C}$. With the advent of microprocessors, linearity became a less important factor and more sensitive, yet somewhat nonlinear quartz temperature sensors had been developed by using a slightly singly rotated Y -cut ($Q = -4^{\circ}$) with sensitivity of 90 ppm $^{\circ}\text{C}^{-1}$ [17] and by utilizing a tuning-fork resonators in flexural and torsional modes [18,19].

It should be noted, that thermal coupling of the object of measurement with the oscillating plate is always difficult and, thus, all piezoelectric temperature sensors have relatively slow response as compared with thermistors and thermocouples.

REFERENCES

1. Benedict, R. P., *Fundamentals of Temperature, Pressure, and Flow Measurements*, 3rd ed. (John Wiley & Sons, New York, 1984).
2. Callender, H. L., On the practical measurement of temperature, *Phil. Trans. R. Soc.*, London, vol. 178, p. 160 (1887).
3. Keystone NTC and PTC thermistors, Catalogue (© Keystone Carbon Company, St. Marys, PA, 1984).
4. Caldwell, F. R., Thermocouple materials, NBS monograph 40, National Bureau of Standards (March 1, 1962).
5. Manual on the use of thermocouples in temperature measurement, ASTM Publication code number 04-470020-40 (© ASTM, Philadelphia, 1981).
6. Timko, M. P., A two terminal IC temperature transducer, *IEEE Journal of Solid-State Circuits*, vol. SC-11, pp. 784-788 (Dec. 1976).
7. Wickersheim, K. A. and Sun, M. H., Fluoroptic thermometry, *Med. Electronics*, pp. 84-91 (Feb. 1987).
8. Schultheis, L., Amstutz, H., and Kaufmann, M., Fiber-optic temperature sensing with ultrathin silicon etalons, in: *Opt. Lett.*, vol. 13, No. 9, pp. 782-784 (1988).
9. Wolthuis, R. A., Mitchell, G. L., Saaski, E., Hartl, J. C., and Afromowitz, M. A., Development of medical pressure and temperature sensors employing optical spectral modulation, in: *IEEE Trans. on Biomed. Eng.*, vol. 38, No. 10, pp. 974-981 (Oct. 1991).
10. Belheim, G., Fritsch, K., and Azar, M. T., A sputtered thin film fiber-optic temperature sensor, in: *Sensors*, pp. 37-43 (Jan. 1990).
11. Hao, T. and Lui, C. C., An optical fiber temperature sensor using a thermochromic solution, in: *Sensors and Actuators A*, vol. 24, pp. 213-216 (1990).
12. Williams, J., Some techniques for direct digitization of transducer outputs, AN7, *Linear Technology Application Handbook* (1990).
13. Venema, A., et al., Acoustic-wave physical-electronic systems for sensors, *Fortschritte der Acustik der 16. Deutsche Arbeitsgemeinschaft für Akustik*, pp. 1155-8 (1990).
14. Vellekoop, M. J., et al., All-silicon plate wave oscillator system for sensor applications, *Proc. IEEE Ultrasonic Symp.*, New York (1990).
15. Smith, W. L., and Spencer, L. J., Quartz crystal thermometer for measuring temperature deviation in the 10-3 to 10-6 $^{\circ}\text{C}$ range, *Rev. Sci. Instrum.*, pp. 268-270 (1963).
16. Hammond, D. L. and Benjaminson, A., Linear quartz thermometer, *Instrum. Control Syst.*, No. 38, p. 115 (1962).
17. Ziegler, H., A low-cost digital sensor system, *Sensors and Actuators*, No. 5, pp. 169-178 (1984).
18. Ueda, T., Kohsaka, F., Iino, T., and Yamazaki, D., Temperature sensor utilizing quartz tuning fork resonator, *Proc. 40th Ann. Freq. Control Symp.*, Philadelphia, PA, pp. 224-229 (1986).
19. BenNise, E. P., and Wiggins, R. B., A resonator temperature transducer with no activity dips, *Proc. 40th Ann. Freq. Control Symp.*, Philadelphia, PA, pp. 216-223 (1986).