

# PART A- Optical waveguides

## LESSON A2-

# Waveguide examples and waveguide parameters

# LESSON A1- What is a waveguide mode?

- A propagation mode of a waveguide **at a given wavelength** is **a stable shape in which the wave propagates**.
- Waves in the form of such a mode of a given waveguide retain exactly the same cross-sectional shape (complex amplitude) as they propagate in the waveguide.
- Waveguide modes at any given wavelength are **completely** determined by the cross-sectional geometry and refractive index profile of the waveguide
- Waveguide mode profiles are **wavelength dependent**

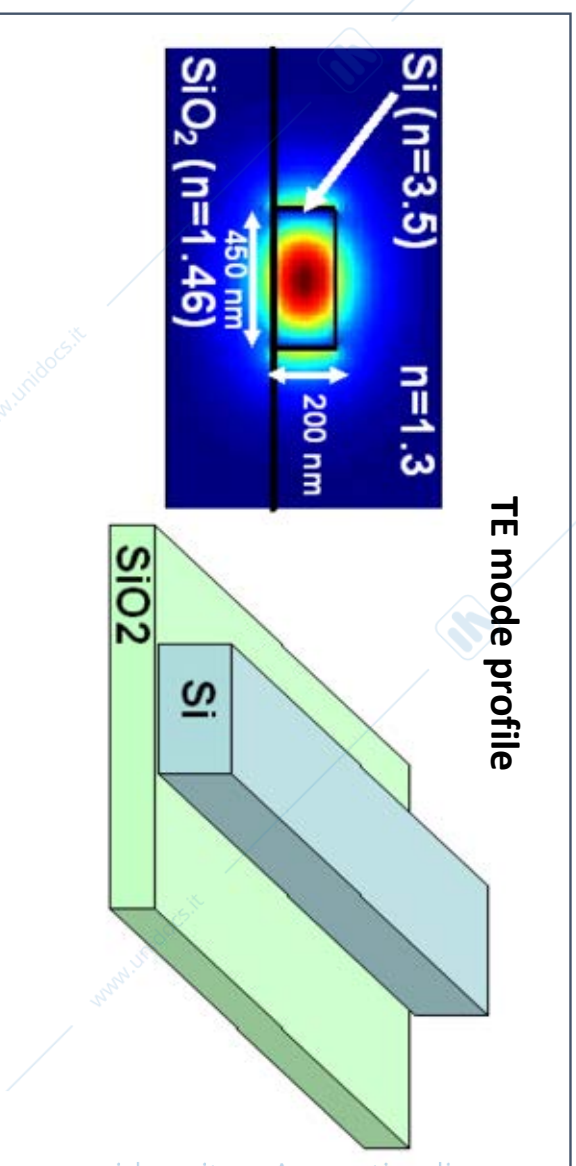

# LESSON A2

## • **Guided mode parameters**

- Examples of waveguides
- The problem of coupling light between two waveguides

# Guided mode parameters

www.unidocs.it

www.unidocs.it

www.



www.unidocs.it

www.unidocs.it



www.unidocs.it

www.unidocs.it



www.unidocs.it

www.unidocs.it

# Effective refractive index versus $V$

We define the normalized propagation constant as :  $b = \frac{\beta^2 - k_2^2}{k_1^2 - k_2^2}$

And the normalized frequency as:  $V = \frac{2\pi}{\lambda} d \sqrt{n_1^2 - n_2^2}$

This plot tells us that for a given value  $V$  (for example we choose the wavelength of the light and the materials of the waveguides) depending on the value of the normalized dimension ( $d/\lambda$ ) we can have a mono or multi-mode waveguide.

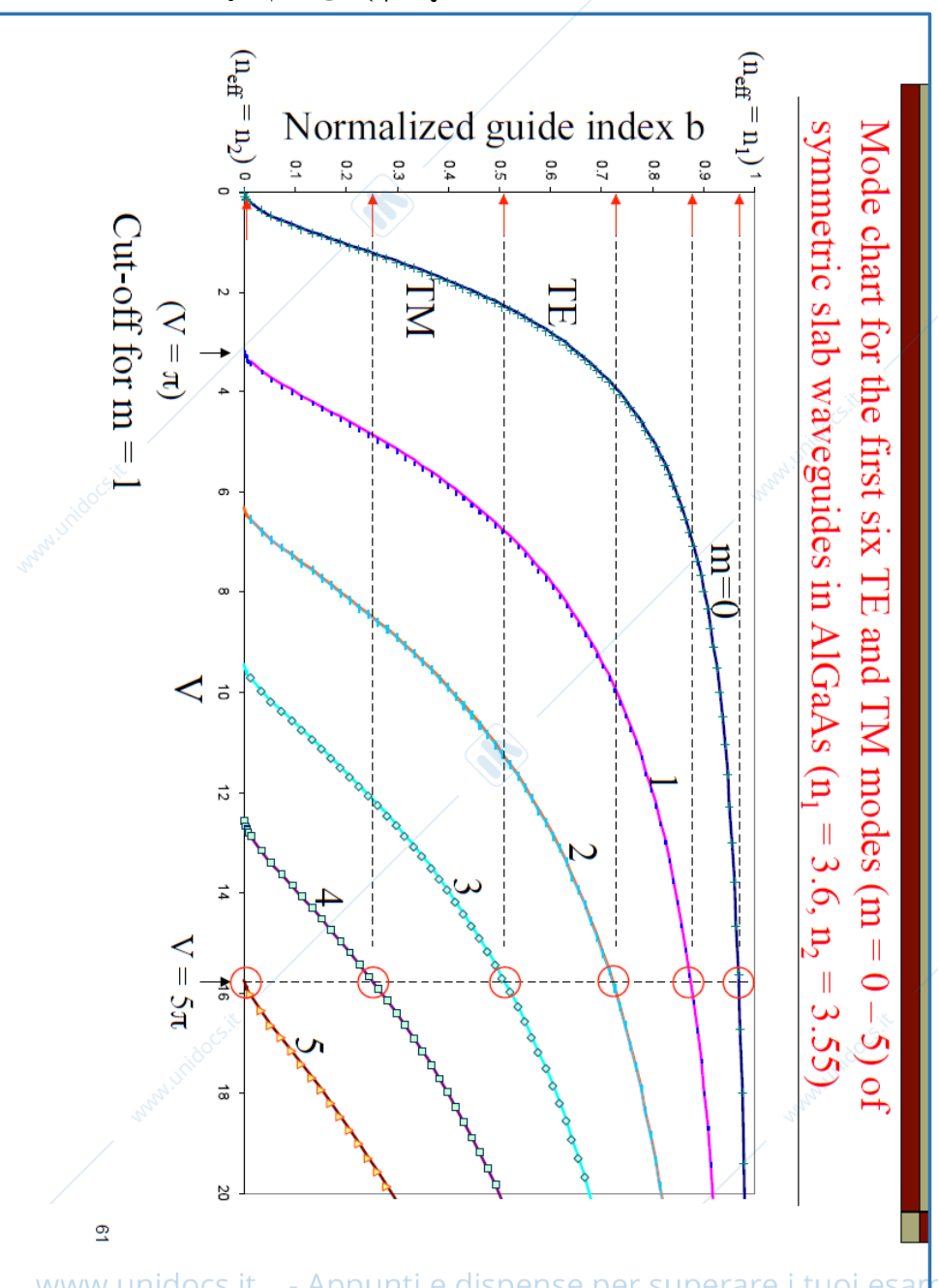

# Dispersion, group velocity and distortion

- Dispersion: the relation between the propagation constant and the wavelength or angular pulsation  $\Rightarrow \beta(\omega)$
- Group velocity: the velocity of a light pulse propagating in the waveguide  $\Rightarrow \frac{\partial \omega}{\partial \beta}$
- Distortion  $\Rightarrow$  when the term  $\partial^2 \beta / \partial \omega^2$  is not negligible we can have pulse broadening and frequency chirp
- The second order derivative measures the group velocity dispersion (ie: group velocity depends on  $\omega$ ) and it is also referred as **chromatic dispersion**  $\Rightarrow$  the same mode, but at different  $\omega$ , propagates with different group velocity

# Group velocity dispersion

- This parameter is often quantified by the quantity **D**

$$D_{\beta} \equiv c\omega \frac{d^2\beta}{d\omega^2} = \lambda^2 \frac{d^2n_{\beta}}{d\lambda^2} .$$

# Power

The energy of the fields of the guided modes in a waveguide flows only in the longitudinal direction. The intensity of a waveguide mode  $\nu$  is thus given by:

$$I_\nu = \bar{\mathbf{S}}_\nu \cdot \hat{\mathbf{z}} = (\mathbf{S}_\nu + \mathbf{S}_\nu^*) \cdot \hat{\mathbf{z}} = (\boldsymbol{\mathcal{E}}_\nu \times \mathcal{H}_\nu^* + \boldsymbol{\mathcal{E}}_\nu^* \times \mathcal{H}_\nu) \cdot \hat{\mathbf{z}},$$

Where  $I_\nu$  is dependent on  $(x, y)$ . We therefore obtain the power  $P$  by integrating over the entire cross section of the waveguide:

For TE and TM modes we have:

$$P_{\text{TE}} = \frac{2\beta}{\omega\mu_0} \int_{-\infty}^{\infty} \int_{-\infty}^{\infty} |\boldsymbol{\mathcal{E}}_y|^2 dx dy.$$

$$P_{\text{TM}} = \frac{2\beta}{\omega} \int_{-\infty}^{\infty} \int_{-\infty}^{\infty} \frac{1}{\epsilon(x, y)} |\mathcal{H}_y|^2 dx dy.$$

# Optical confinement factor $\Gamma$

**The optical confinement factor of a guided mode is defined as the fraction of its power in the core region.**

In an active waveguide, such as that in a semiconductor laser or in a waveguide amplifier, the core guiding region is where the optical gain is, whereas the substrate and cover regions are usually passive media without an optical gain. Only the fraction of power in the core region “sees” a gain, and the effective gain of a given mode is proportionally reduced. Therefore, the confinement factor is very important in assessing the effective gain of an active optical waveguide for a particular guided mode.

Example: TE mode optical confinement factor of slab waveguide of thickness  $d$

$$\Gamma_{\text{TE}} = \frac{\int_{-d/2}^{d/2} |\mathcal{E}_y(x)|^2 dx}{\int_{-\infty}^{\infty} |\mathcal{E}_y(x)|^2 dx} = \frac{\text{Power}_{\text{core}}}{\text{Power}_{\text{total}}}$$

# Optical confinement factor of slab waveguide

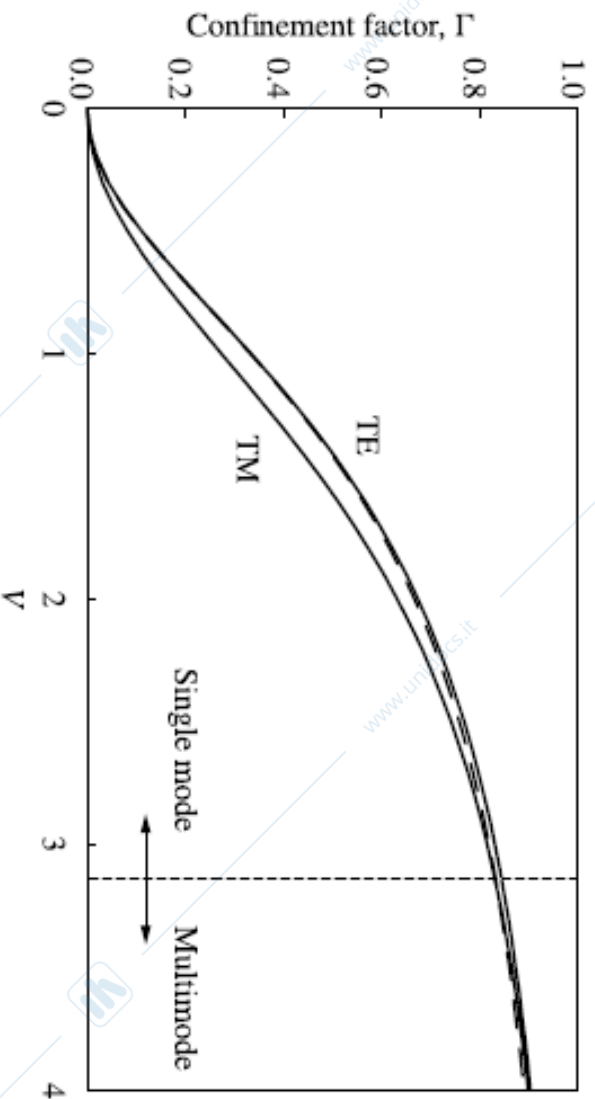
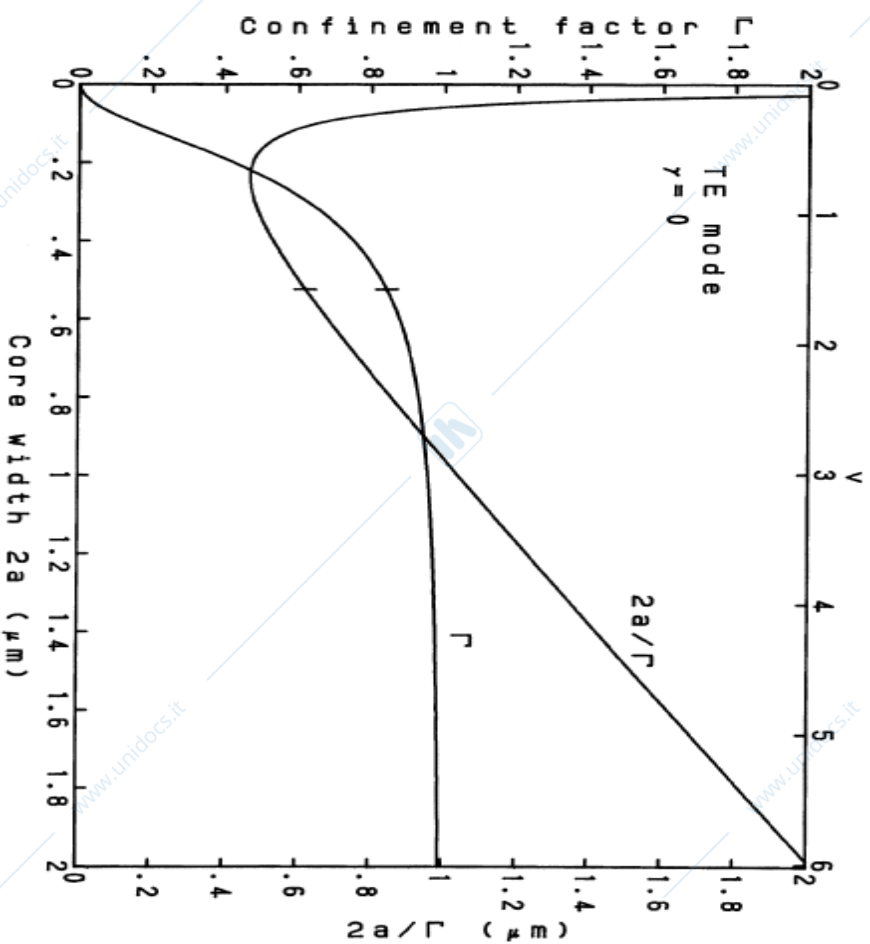
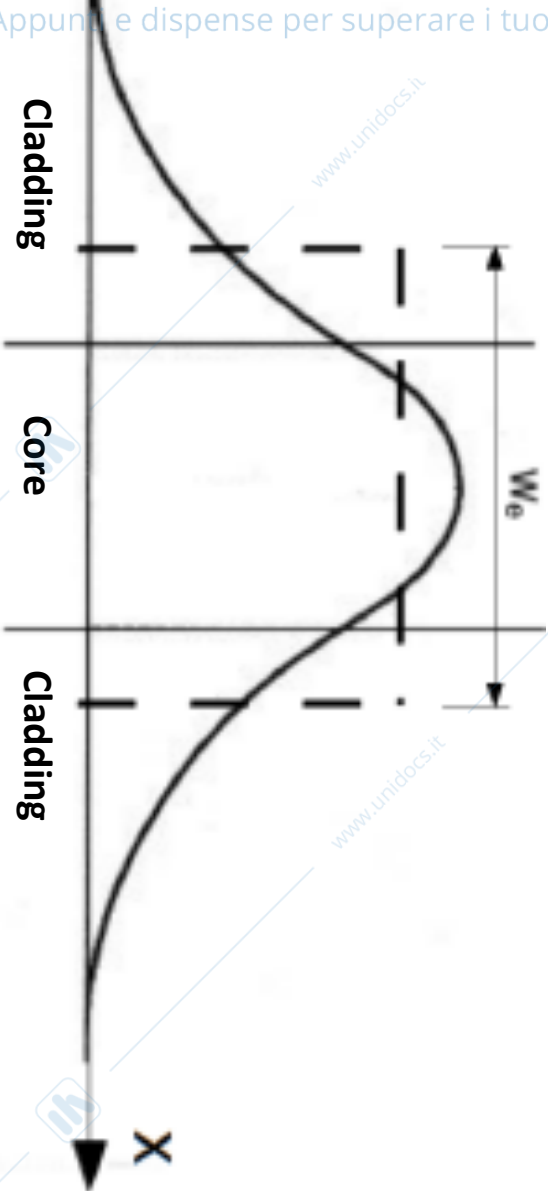

**Figure 2.8** Confinement factors of the fundamental TE and TM modes of a symmetric slab waveguide as a function of the waveguide  $V$  number.  $\Gamma_{TE}$  is a function of  $V$  only, but  $\Gamma_{TM}$  is a function of both  $V$  and  $n_1/n_2$ .

Either the fundamental TE or TM mode has the largest confinement factor respect to all other modes.

**Fundamental modes are those that confine most of the optical power in the core region !!**

# Effective waveguide thickness: $w_e = d/\Gamma$



# Optical attenuation

- Several factors contribute to attenuation of the power of an optical wave propagating in an optical waveguide. When an optical wave propagates in a medium with an attenuation coefficient  $\alpha$ , its intensity decays exponentially with distance according to:

$$P_{\text{out}} = P_{\text{in}} e^{-\alpha l}$$

Where  $P_{\text{in}}$  and  $P_{\text{out}}$  are the optical power IN and OUT; they are expressed in Watts. The attenuation  $\alpha$  is therefore given per unit of length (ie:  $\text{cm}^{-1}$  or  $\text{m}^{-1}$ )

- In practical engineering applications, it is convenient to use decibels (dB) as a measure of relative changes of quantities. The attenuation coefficient  $\alpha$  is then measured in decibels per meter. In the case of low-loss fibers, the propagation length in a fiber is usually measured in kilometers, and  $\alpha$  is conventionally given in decibels per kilometer:

$$\alpha(\text{dB km}^{-1}) = -\frac{1}{l(\text{km})} 10 \log \frac{P_{\text{out}}}{P_{\text{in}}}$$

# Esercizio

- Se una guida ottica ha perdite di  $-2\text{dB/cm}$  quanto vale  $\alpha$ ? Esprimere  $\alpha$  in  $\text{cm}^{-1}$

# Examples of optical waveguides

www.unidocs.it

www.unidocs.it

www.



www.unidocs.it

www.unidocs.it



www.unidocs.it

www.unidocs.it



www.unidocs.it

www.unidocs.it

www.unidocs.it - Appunti e dispense per superare i tuoi esami universitari

www.unidocs.it - Appunti e dispense per superare i tuoi esami universitari



# Silicon photonics slab

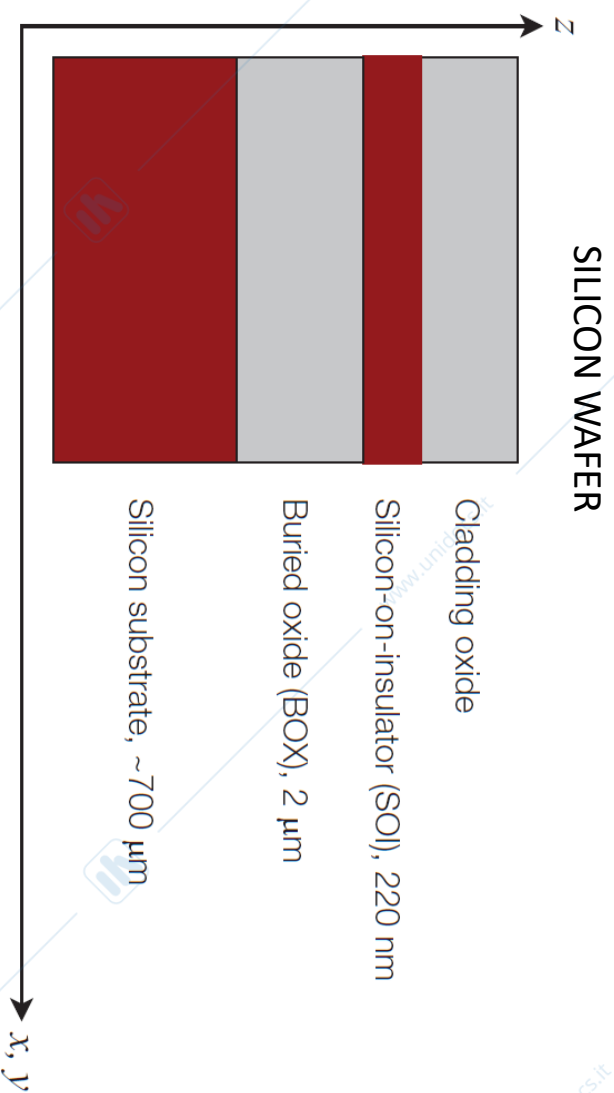

**Figure 3.1** Cross-sectional view of silicon-on-insulator (SOI) wafer.

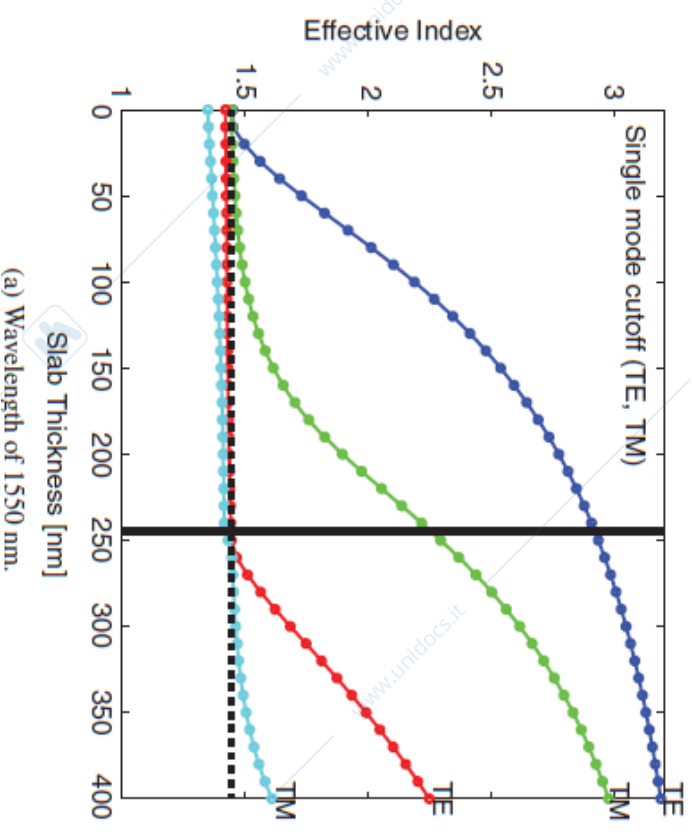

Index contrast at 1.55 $\mu\text{m}$  is

$$\Delta n = 3.48 - 1.45 = 2.03$$

High index contrast waveguides!

# Silicon photonic waveguides

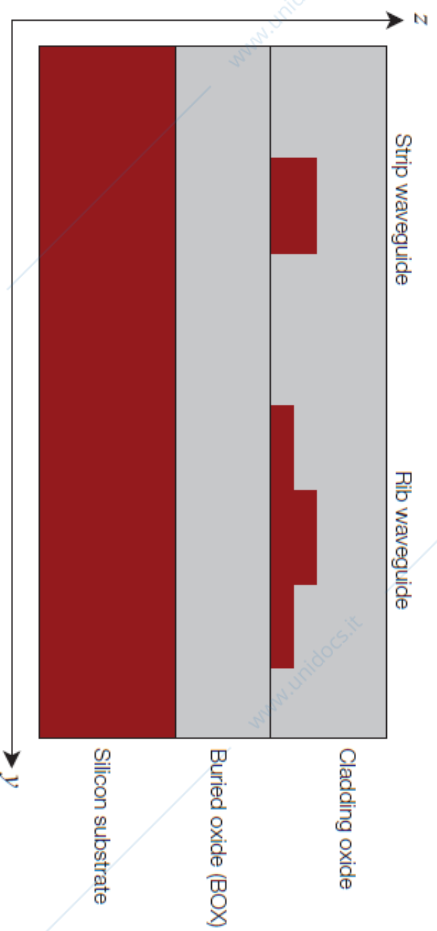

**Figure 3.4** Common waveguides in silicon photonics. (Left) Strip waveguide, also known as channel waveguides, photonic wires, or ridge waveguides. (Right) Rib waveguide, also known as ridge waveguide or strip-loaded ridge waveguide.

There are several types of waveguides used in

silicon photonics. The strip waveguide (also known as channel, photonic wire, or ridge waveguide), Figure 3.4(left), is typically used for routing as it offers tight bend radii. The rib waveguide (also known as strip-loaded ridge, or ridge waveguide), Figure 3.4(right), is used for electro-optic devices such as modulators, since it allows for electrical connections to be made to the waveguide.

**Both waveguides can be made to have a loss of less than 3 dB/cm.** Oxide cladding is used to protect the devices and to permit the fabrication of metal interconnects above the waveguides.

**Why loss is so low at 1550nm or 1310 nm?**

# Optical fibers: structure

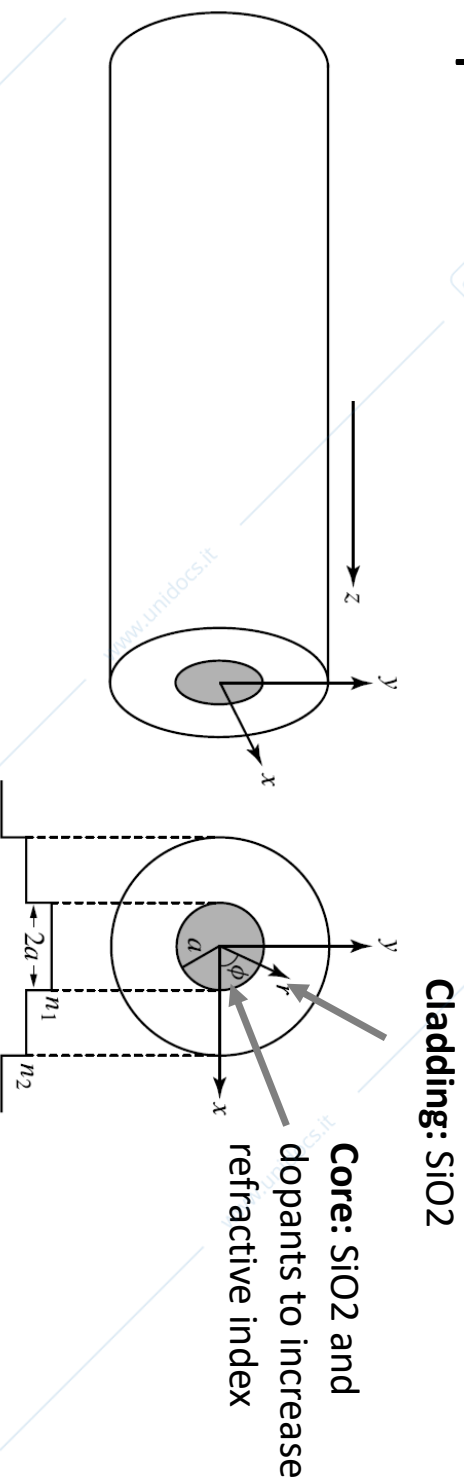
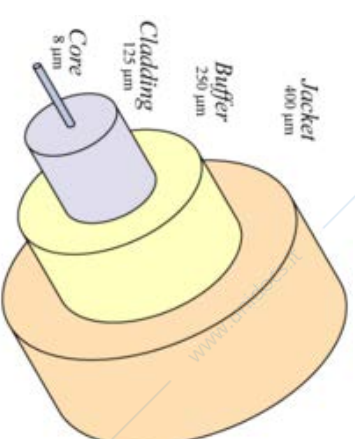

Figure 3.1 Step-index optical fiber with a core radius  $a$ .

An optical fiber is basically a cylindrical dielectric waveguide with a circular cross section where a high-index waveguiding core is surrounded by a low-index cladding. **Index contrast is typically  $\Delta n=0.005$**

**Optical fibers are usually made of silica (SiO<sub>2</sub>) glass.** The index step and profile are controlled by the concentration and distribution of dopants. For example, **the core can be doped with germania (GeO<sub>2</sub>) or alumina (Al<sub>2</sub>O<sub>3</sub>)** or other oxides, such as P<sub>2</sub>O<sub>5</sub> or TiO<sub>2</sub>, for a slightly higher index than that of a silica cladding.

The **core diameter**,  $2a$ , typically ranges from a few micrometers for a **single-mode fiber** to less than 100  $\mu\text{m}$  for a **multimode fiber**. It is designed for the fiber to support a desired number of guided modes. The **outer diameter** of a fiber is that of the outside boundary of its cladding, which is typically about 100  $\mu\text{m}$  or somewhat larger



# Fiber fundamental mode

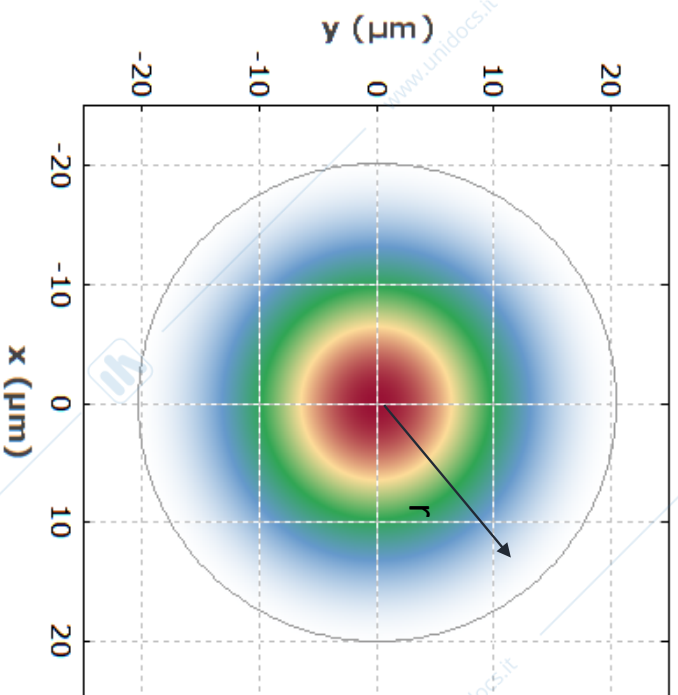

Intensity profile of the fundamental mode in a multimode fiber.  
The gray circle indicates the core/cladding boundary.

The fiber fundamental mode profile can be approximated with a Gaussian shape

$$E(r) = \sqrt{\frac{2}{\pi w_f^2}} \exp\left(-\frac{r^2}{w_f^2}\right)$$

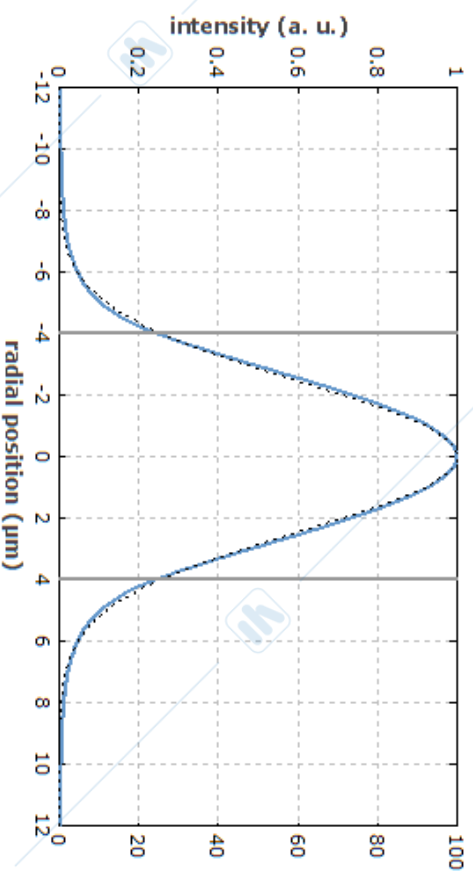

The FWHM of the intensity profile is often called **SPOT-SIZE**

# Intensity of modes of a multi-mode fiber

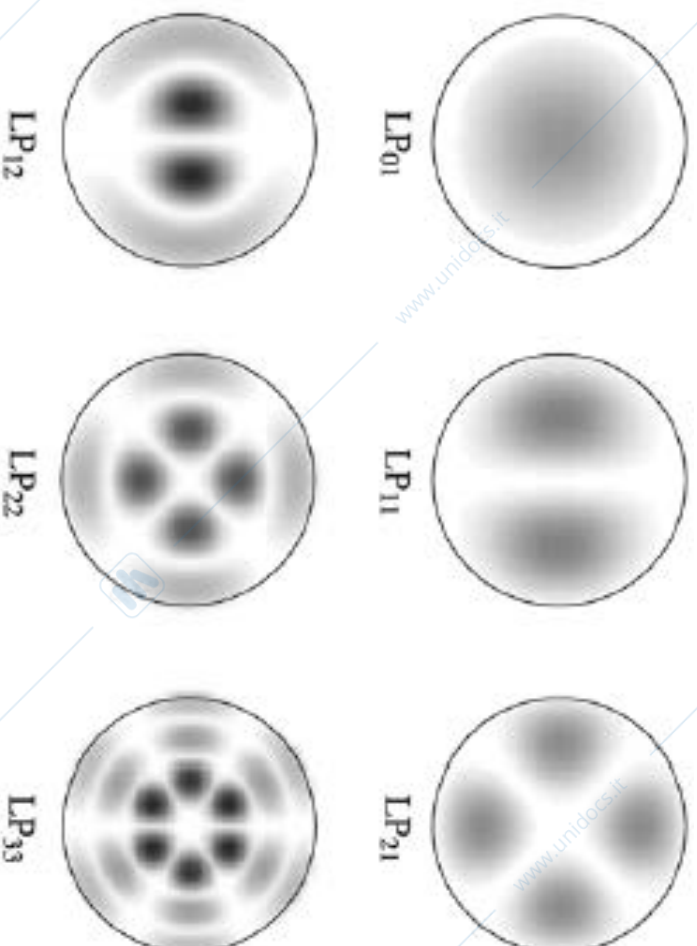

**Figure 3.5** Intensity profiles of a few LP modes. The intensity pattern of the  $LP_{am}$  mode consists of  $m$  node lines intersecting at the center and  $n$  intensity peaks counted radially out from the center. The thin circle in each profile locates the core boundary of a step-index fiber.

CORNING

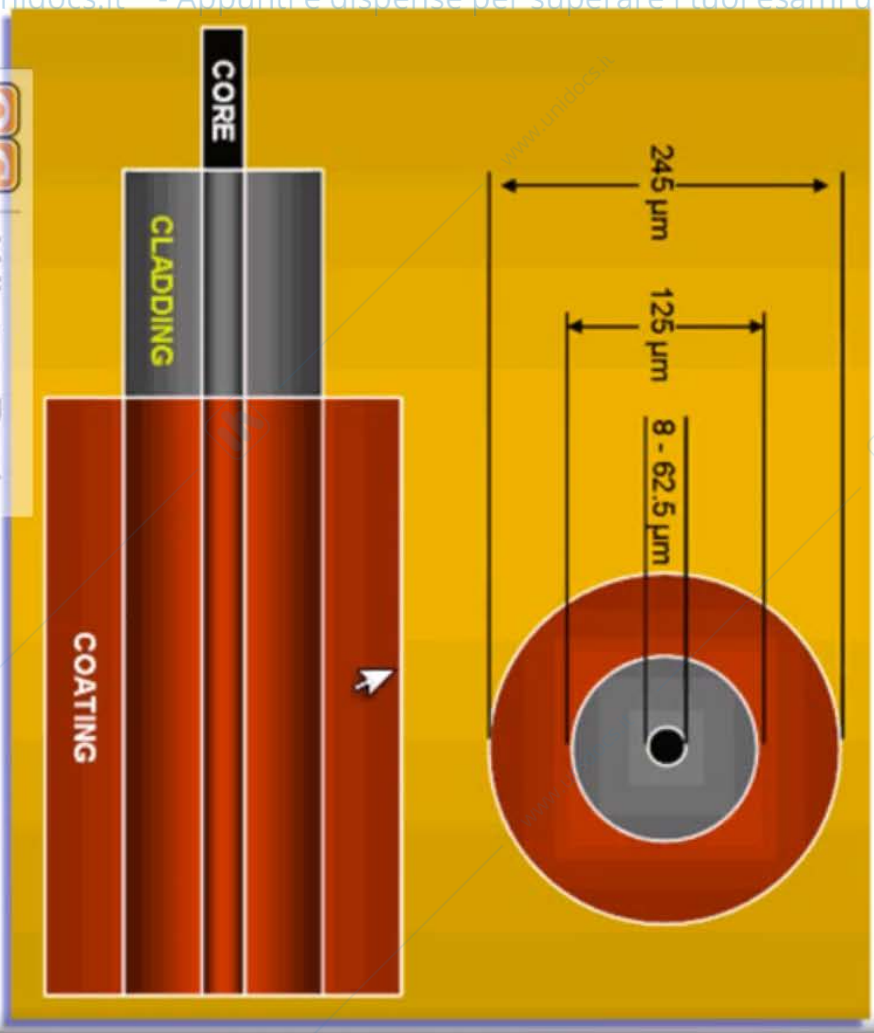

Winter Park  
TECH

printable pdf

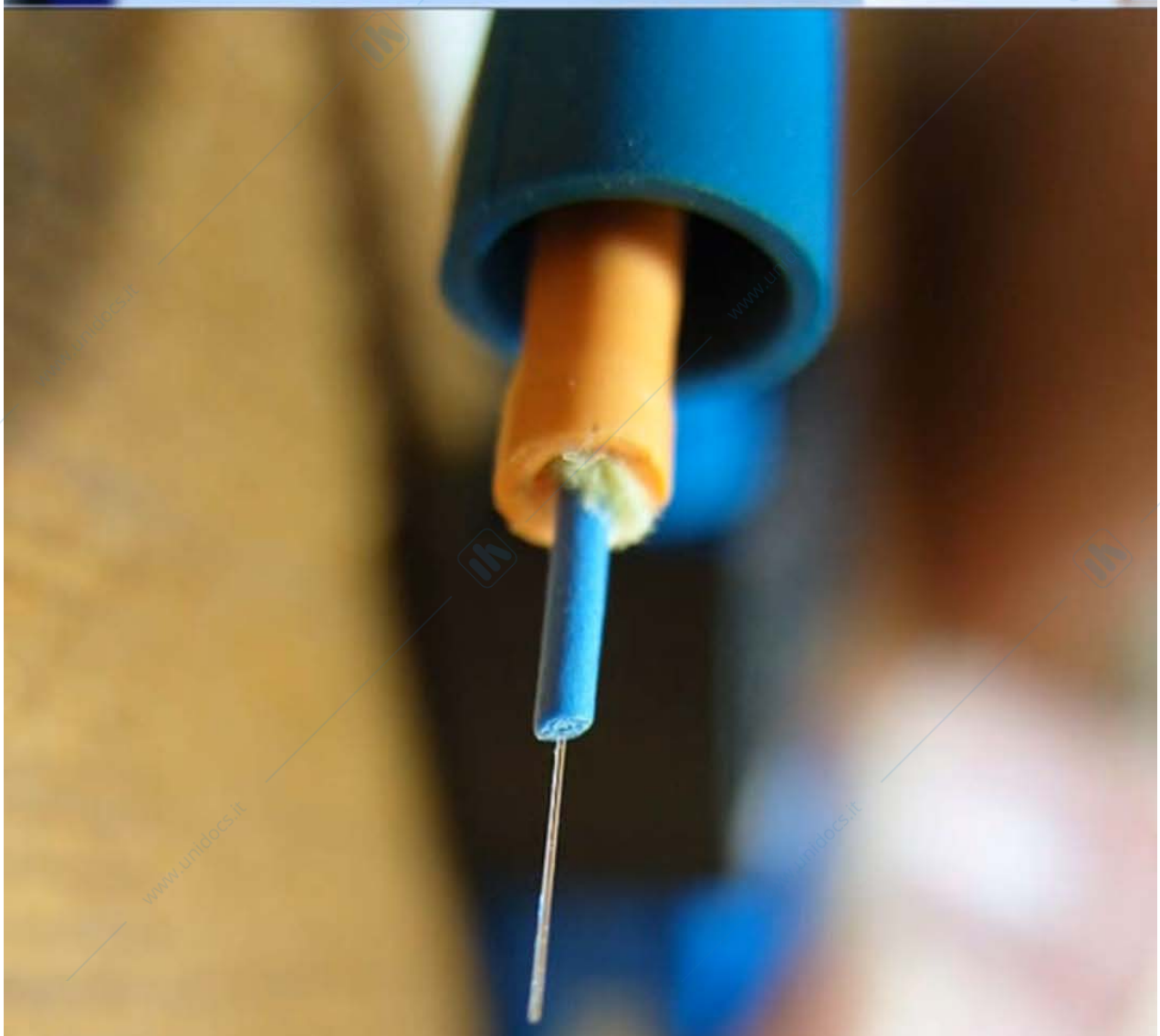

# Single mode Fibers (SMF): cables and connectors

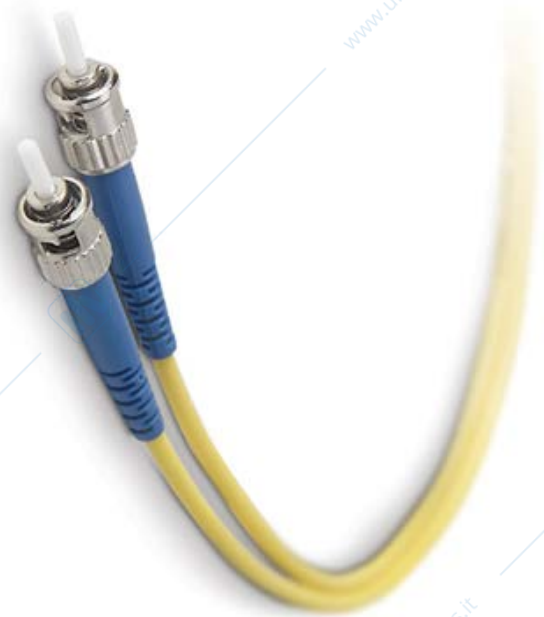

**FC/PC:** The "PC" stands for "physical contact" because these connectors allow the surfaces of two connected fibers to be in direct contact with each other.

**FC/APC:** The "APC" stands for "angled physical contact" because these connectors allow the surfaces of two connected fibers to be in direct contact with each other and because the fiber end is polished at an angle to prevent reflected light from traveling back up the fiber.

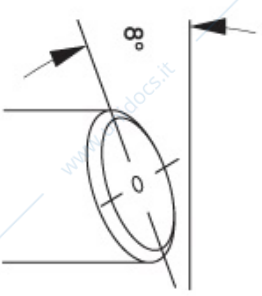

# Multi-mode fibers (MMF)



## Single Mode & Multi-mode Fiber Patch Cable

# Dispersion in multi-mode fibers

- An optical pulse propagating in a multi-mode fiber can be distorted because we have:
1. Chromatic dispersion of each mode => not very relevant in this case, because MMF are used only in short-distance links.
  2. Intermodal dispersion: each mode has a different dispersion relation (ie:  $\beta_{LP01, LP11, \dots}(\omega)$  ) => each mode propagates at different group velocity

# Optical fiber attenuation and optical communication windows

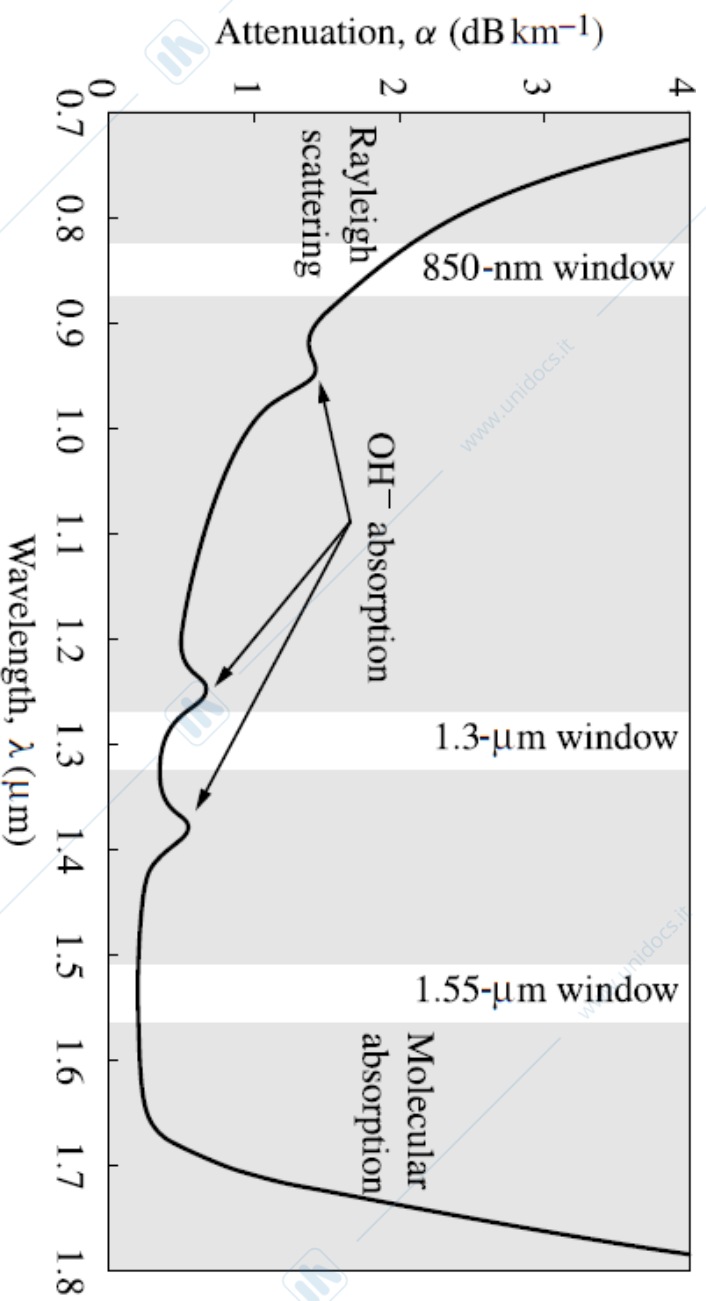

**Figure 3.8** Spectral dependence of loss mechanisms and total attenuation in a fiber. Also shown are spectral ranges for three communication windows. (Based on data from assorted sources.)

# Physical reasons for fiber attenuation

**Rayleigh scattering.** The intrinsic Rayleigh scattering in a fiber is caused by variations in density and composition that are built into the fiber during the manufacturing process. They are primarily a result of thermal fluctuations in the density of silica glass and variations in the concentration of dopants before silica passes its glass transition point to become a solid. These variations are a fundamental thermodynamic phenomenon and cannot be completely removed. They create microscopic fluctuations in the index of refraction, which scatter light in the same manner as microscopic fluctuations of the density of air scatter sunlight.

**Impurity absorption.** Impurity absorption could be very important in the near infrared region because most impurity ions such as OH<sup>-</sup>, Fe<sup>2+</sup>, and Cu<sup>2+</sup> form absorption bands in this region where both electronic and molecular absorption losses of the host silica glass are very low.

**Molecular absorption.** In the infrared region, the absorption of photons is accompanied by transitions between different vibrational modes of silica molecules.

# Optical communication windows

- At present, the best fibers have attenuation as low as  $0.15 \text{ dB km}^{-1}$  at  $1.55 \mu\text{m}$  and  $0.3 \text{ dB km}^{-1}$  at  $1.3 \mu\text{m}$ , while attenuation at  $850 \text{ nm}$  is typically  $2 \text{ dB km}^{-1}$ .
- This is the reason why the wavelength of  $1.55 \mu\text{m}$  is chosen for long-distance optical communication systems and the wavelength of  $1.3 \mu\text{m}$  is suitable for metropolitan and wide-area networks, while wavelengths in the  $850\text{-nm}$  window are only useful for local optical links.

# Dispersion of step-index SMF

## 1.31 $\mu\text{m}$ Zero-Dispersion in Step-Index SM Fiber

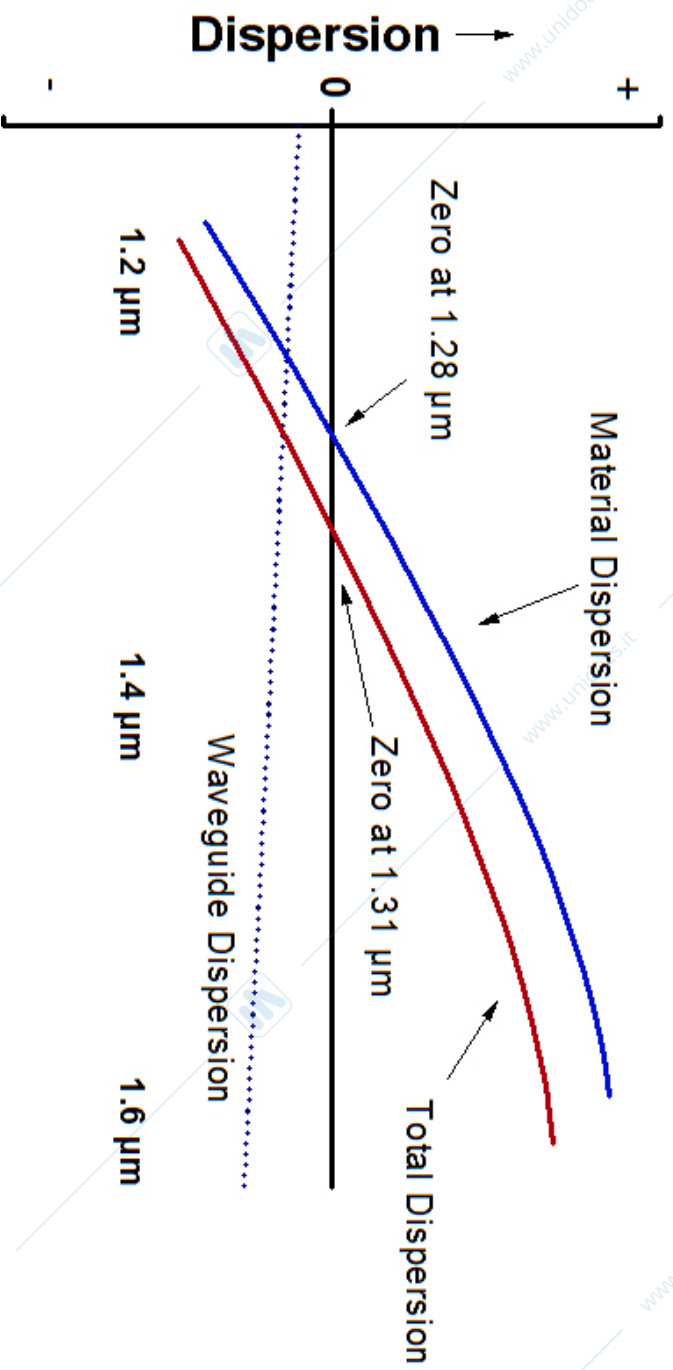

In standard step-index single-mode fiber, the sum of the material and waveguide dispersion is zero near 1310nm, which is called the *zero-dispersion wavelength*.

# Dispersion shifted fibers

## 1.55 $\mu\text{m}$ Zero Dispersion-Shifted Fiber

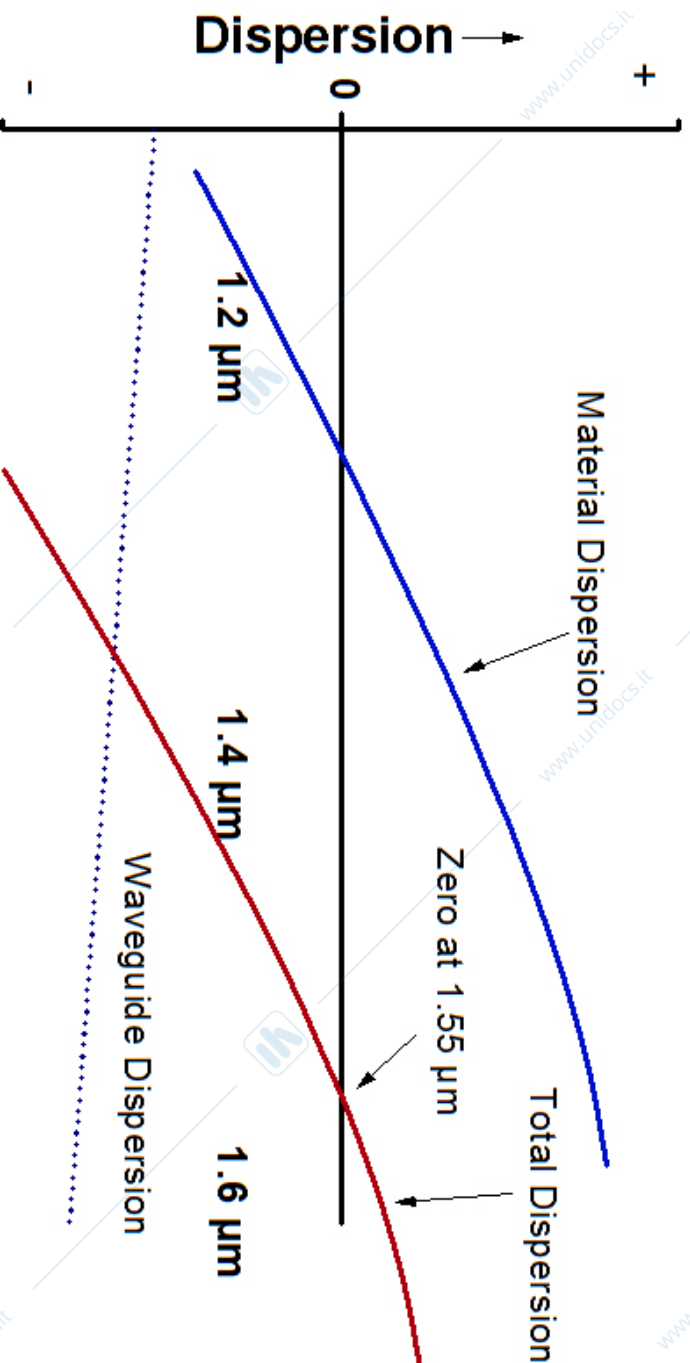

By varying the fiber's waveguide structure, the waveguide dispersion can be shifted up or down, thus changing the zero-dispersion point. Fiber in which the zero-dispersion wavelength has been changed is called *zero dispersion-shifted fiber*.

An initial strategy was to alter the waveguide structure to shift the zero-dispersion point to the signal wavelength of 1550 nm, creating zero-dispersion shifted fiber (see the diagram to the left).

Unfortunately, fixing the dispersion problem is not so simple. When multiple optical channels pass through the same fiber at wavelengths where dispersion is very close to zero, they suffer from a type of crosstalk called four-wave mixing. The degradation is so severe that zero dispersion-shifted fiber cannot be used for dense-WDM systems. To avoid four-wave mixing, the zero-dispersion wavelength is moved outside the transmission band. So-called nonzero dispersion-shifted fibers have a dispersion that is low, but nonzero in the 1550 nm band (typically 0.1 to 6 ps/nm\*km). Although dispersion is minimized, it is still present.

# Recommended video on optical fibers:

- <https://www.youtube.com/watch?v=NXpPi-hLpDU>

# Coupling light between two waveguides

# Light coupling

- In a system, it is always necessary to couple light from sources, such as lasers or light emitting diodes, to transmission components, which are usually dielectric waveguides or fibers. In other cases we need coupling the light from the fiber to various functional devices, such as optical switches, power dividers, amplifiers, and modulators.
- We have to evaluate the coupling efficiency between the modes of two mono-mode waveguides that might have very different guided mode spot-size=> coupling loss

# Example (1): coupling light source with optical fiber

**Coupling laser diode output light into optical fiber**

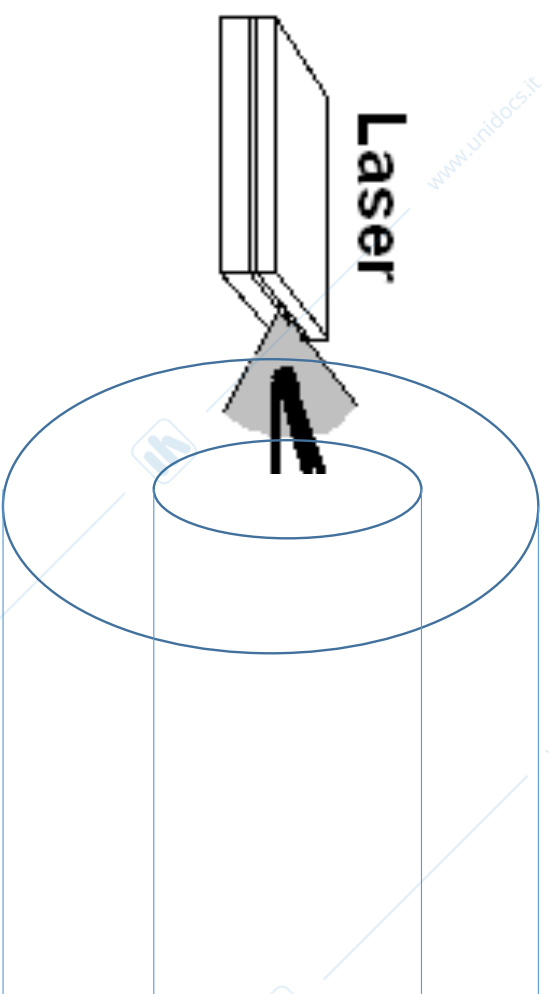

# Example (II): coupling fiber with a Silicon photonic integrated circuit

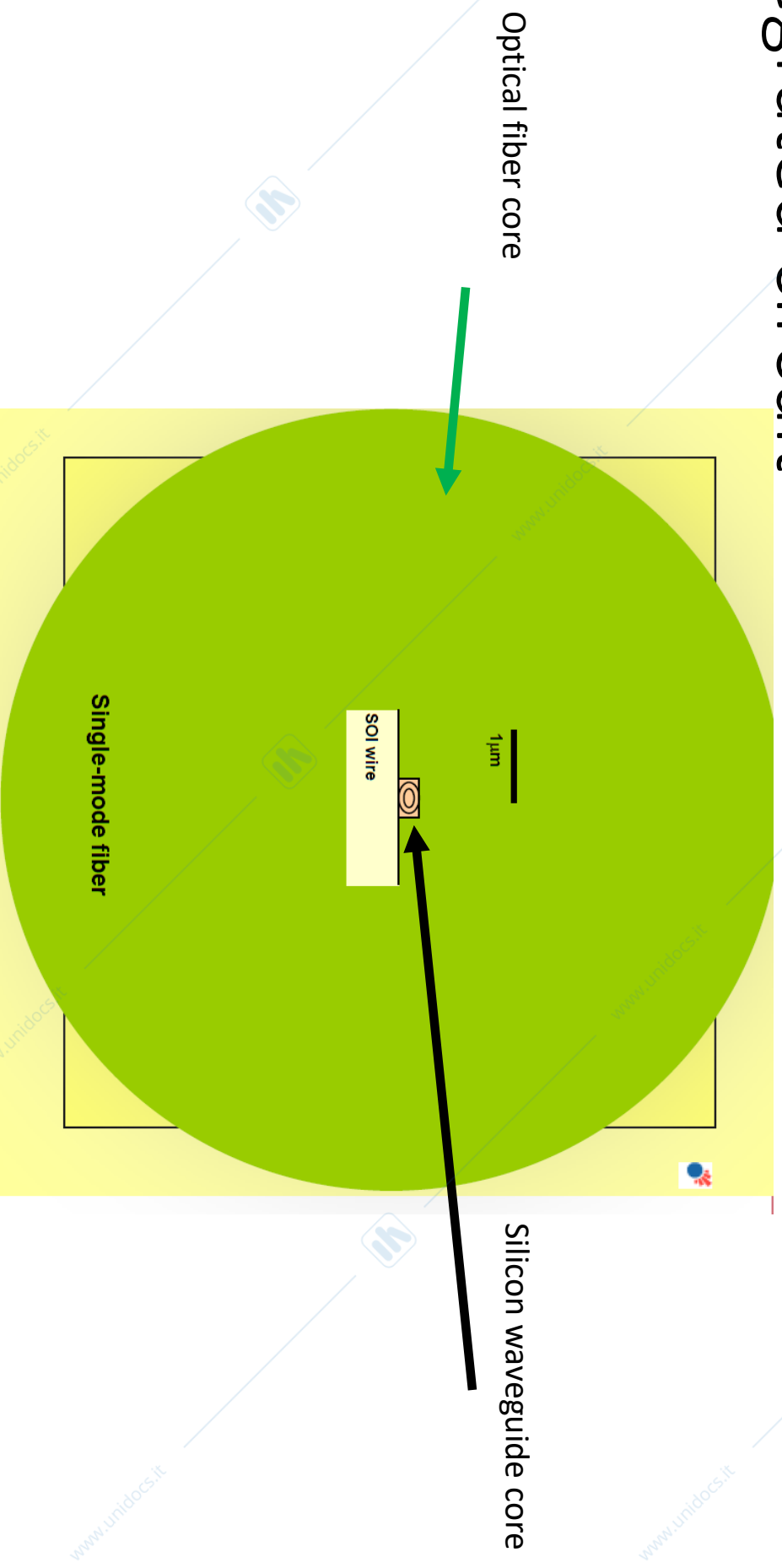

# Coupling efficiency

- The coupling efficiency gives how much power of the optical spot  $E_1$  is coupled with the guided mode  $E_2$
- It is calculated as:

$$\eta_c = \frac{|\iint E_1(x, y)E_2^*(x, y)dx dy|^2}{\int |E_1|^2 dx dy \cdot \int |E_2|^2 dx dy}$$

- $E_1$  is the laser field at the input plane of the optical fiber and  $E_2$  is the fiber guided mode

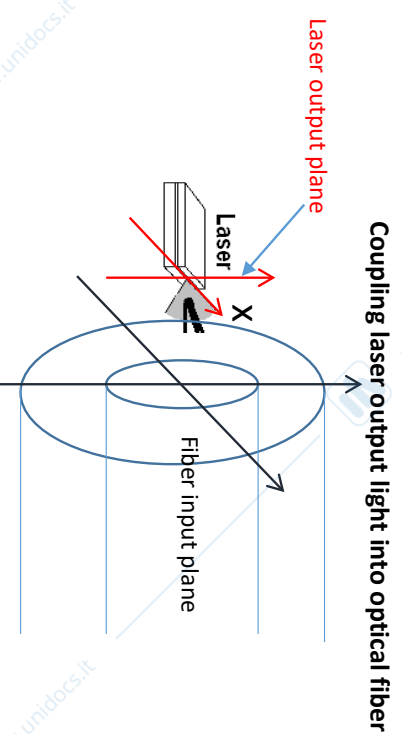

We need  $E_1$  for calculating the coupling efficiency

# Coupling laser => fiber

- The coupling efficiency from laser output to optical fiber is therefore calculated as:

$$\eta_c = \frac{|\iint E_1(x, y)E_2^*(x, y)dxdy|^2}{\int |E_1|^2 dxdy \cdot \int |E_2|^2 dxdy}$$

- Where  $E_1$  is the laser field at the input plane of the optical fiber and  $E_2$  is the fiber guided mode

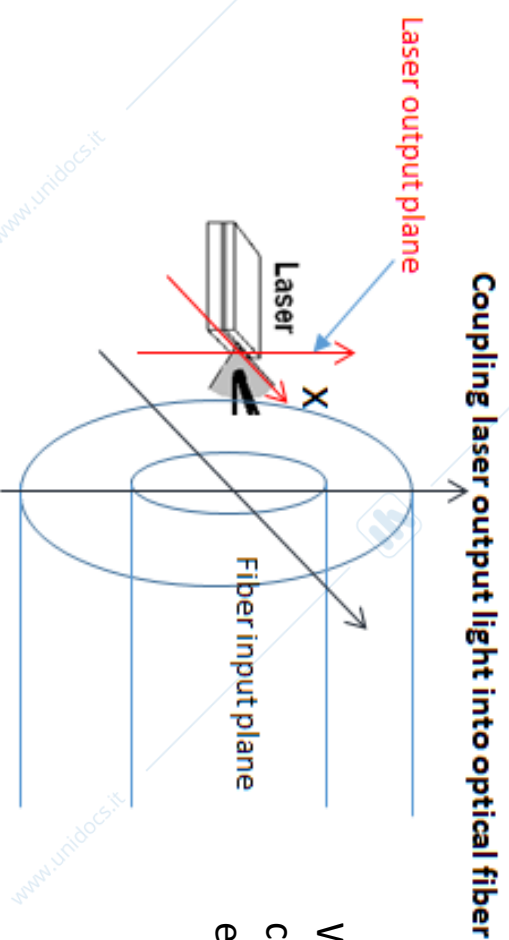

We need therefore  $E_1$  to calculate the coupling efficiency

# Calculation of the field E1

The laser output field is approximated with a Gaussian shape:

$$E_1(x, y) = \sqrt{\frac{2}{\pi w_x w_y}} \exp\left(-\frac{x^2}{w_x^2} - \frac{y^2}{w_y^2}\right)$$

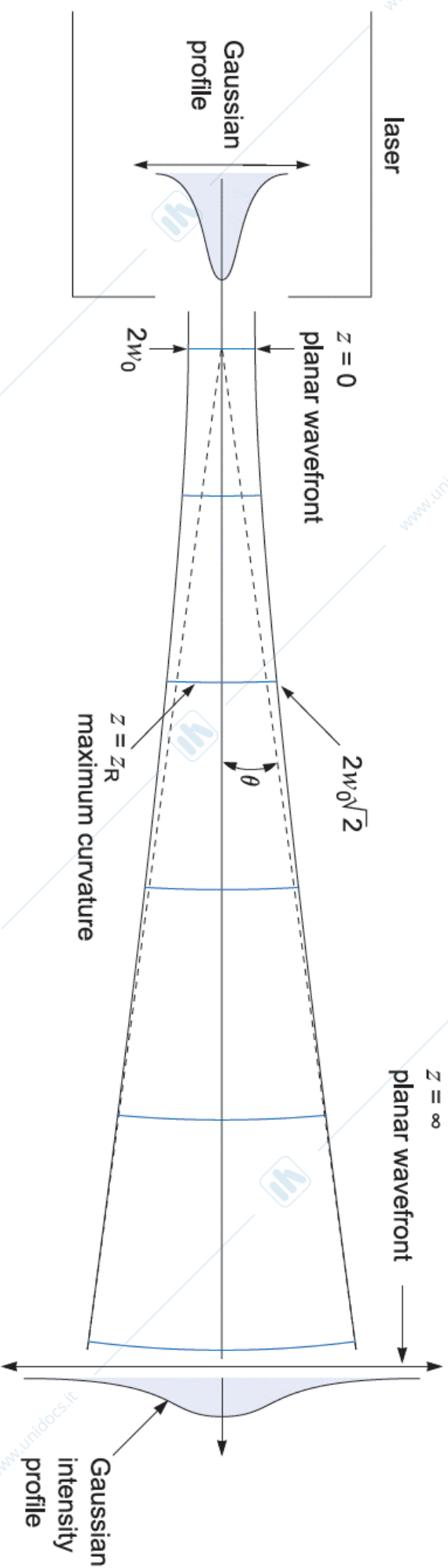

# Example of calculated coupling efficiency (I)

- Coupling loss due to spot-size mismatch

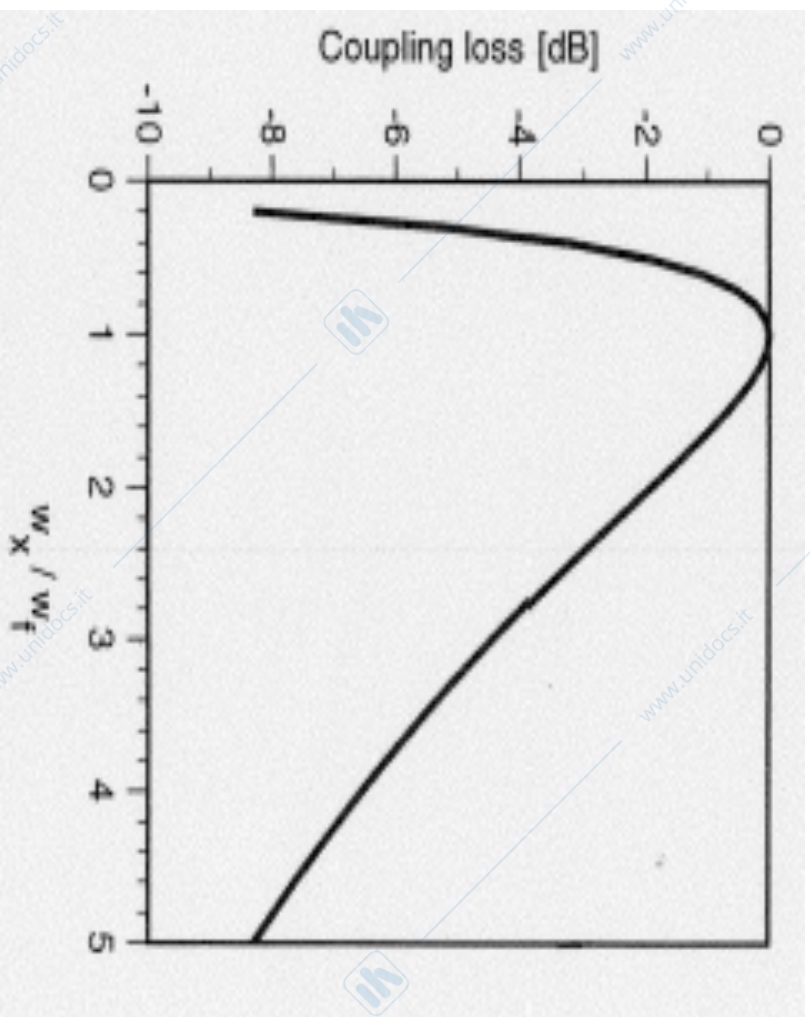

$W_x$ : laser spot-size at the input fiber

$W_f$ : spot-size of the mode of the optical fiber

# Example of calculated coupling efficiency ( $\eta$ )

- **Coupling loss due to lateral misalignment**

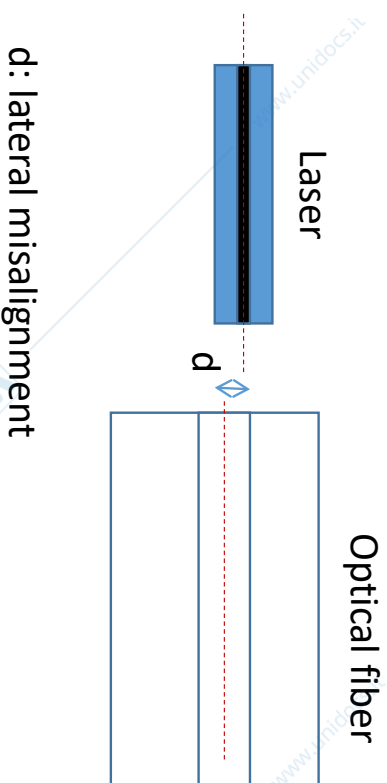

d: lateral misalignment

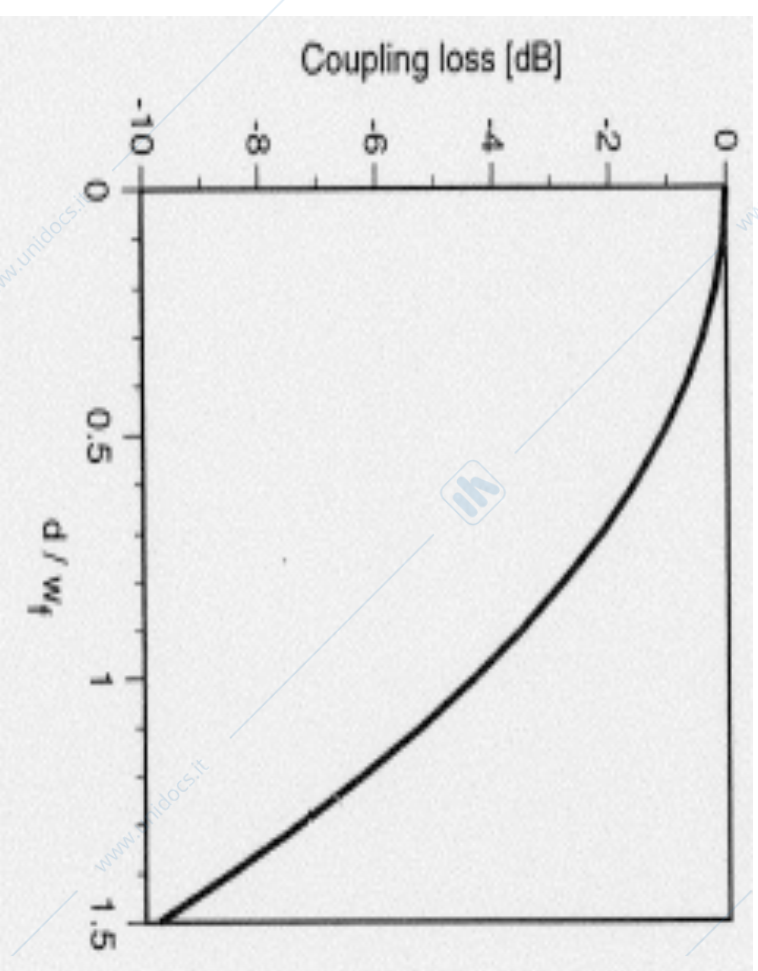

# Solution to optimize laser-fiber coupling

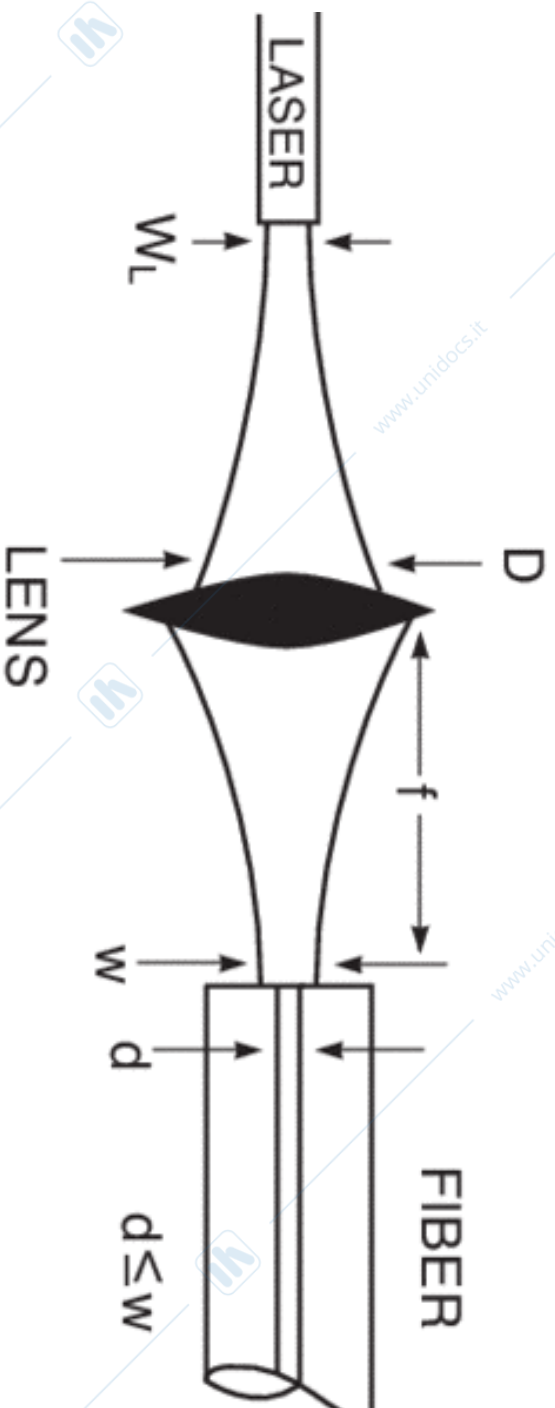

# Solution to optimize Silicon waveguide => fiber coupling

## • Narrow waveguide tip

- mode is 'squeezed out' of core
- captured by overlay waveguide

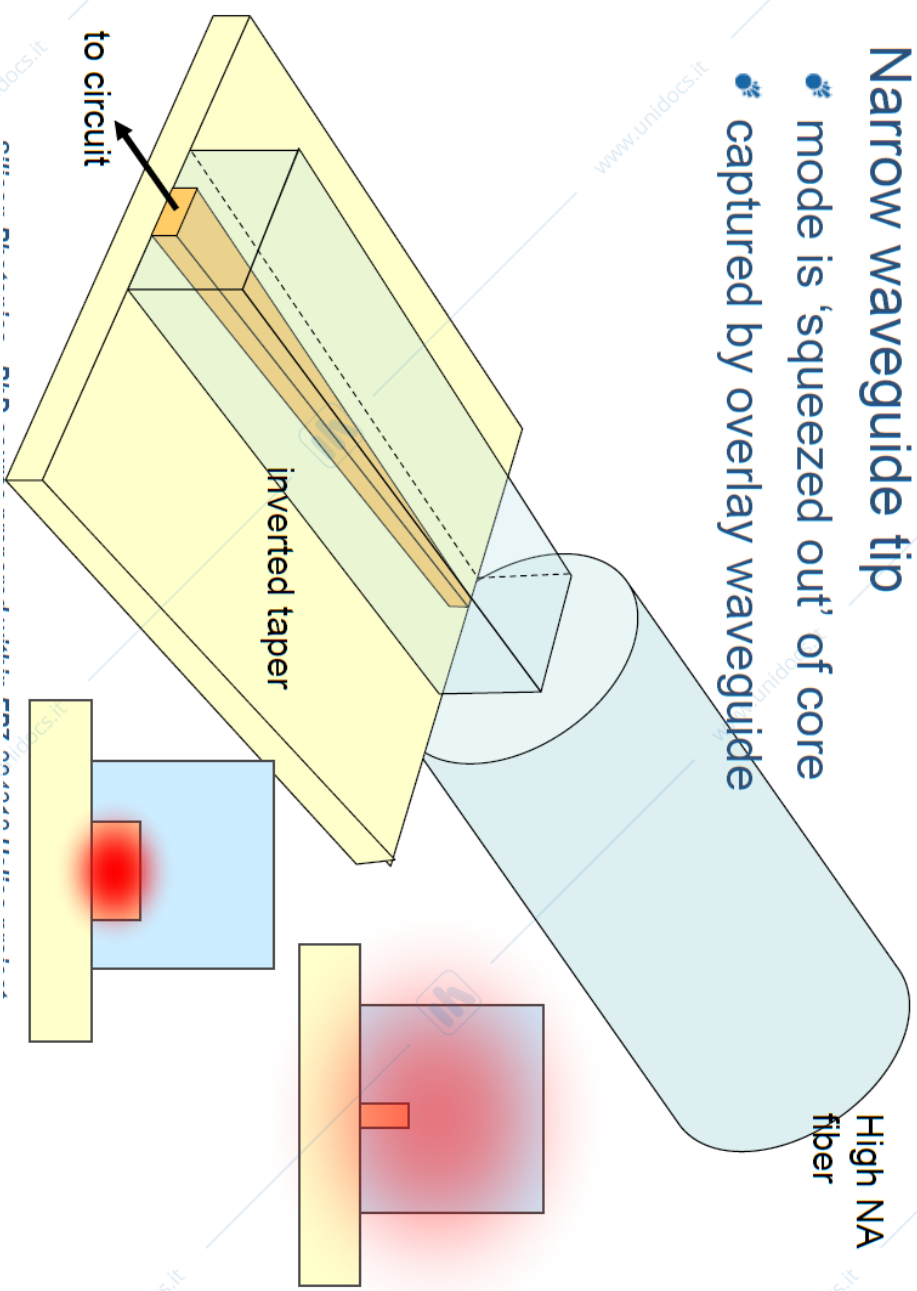

# Summary slide

- 1) Recognize different types of optical waveguides
- 2) Define optical waveguide parameters and know expression for calculating them
- 3) Know how coupling loss can be calculated. Recognize solutions to minimize coupling loss

Next lesson: LESSON A3

• **Optical interconnect**